

UNIVERSIDADE FEDERAL DO RIO GRANDE DO SUL
ESCOLA DE ENGENHARIA - CURSO DE ENGENHARIA MECÂNICA
TRABALHO DE CONCLUSÃO DE CURSO

ANALYSIS OF STATIC FORCES IN END MILLING OF TOOLOX® 44

por

Gretcheen Gricel Suazo Kunhardt

Monografia apresentada ao Departamento de Engenharia Mecânica da Escola de Engenharia da Universidade Federal do Rio Grande do Sul, como parte dos requisitos para obtenção do diploma de Engenheiro Mecânico.

Porto Alegre, novembro de 2021.

DADOS INTERNACIONAIS DE CATALOGAÇÃO

CIP - Catalogação na Publicação

Kunhardt, Gretcheen Gricel Suazo
ANALYSIS OF STATIC FORCES IN END MILLING OF TOOLOX®
44 / Gretcheen Gricel Suazo Kunhardt. -- 2021.
17 f.
Orientador: Prof. Dr. Heraldo José de Amorim.

Coorientadora: Eng. Michele Bernardes de Almeida
Ribeiro.

Trabalho de conclusão de curso (Graduação) --
Universidade Federal do Rio Grande do Sul, Escola de
Engenharia, Curso de Engenharia Mecânica, Porto
Alegre, BR-RS, 2021.

1. Toolox® 44. 2. End milling. 3. Static force. 4.
Optimization. I. de Amorim, Prof. Dr. Heraldo José,
orient. II. Ribeiro, Eng. Michele Bernardes de
Almeida, coorient. III. Título.

Elaborada pelo Sistema de Geração Automática de Ficha Catalográfica da UFRGS com os
dados fornecidos pelo(a) autor(a).

Gretcheen Gricel Suazo Kunhardt

ANALYSIS OF STATIC FORCES IN END MILLING OF TOOLOX® 44

ESTA MONOGRAFIA FOI JULGADA ADEQUADA COMO PARTE DOS
REQUISITOS PARA A OBTENÇÃO DO TÍTULO DE
ENGENHEIRO MECÂNICO
APROVADA EM SUA FORMA FINAL PELA BANCA EXAMINADORA DO
CURSO DE ENGENHARIA MECÂNICA

Prof. Cirilo Seppi Bresolin
Coordenador do Curso de Engenharia Mecânica

Área de concentração: Processos de Fabricação

Orientador: Prof. Dr. Heraldo José de Amorim

Coorientadora: Eng. Michele Bernardes de Almeida Ribeiro

Comissão de Avaliação:

Prof. Dr. André João de Souza

Prof^ª. Dra. Cíntia Cristiane Petry Mazzaferro

Prof. Dr. Heraldo José de Amorim

Porto Alegre, 16 de novembro de 2021

A mi querida abuela Yolanda.

AGRADECIMIENTOS

A mis padres, Manuel y Gricel, que me apoyaron durante toda mi jornada de estudios en Brasil, gracias por el apoyo y amor incondicional.

A mis hermanas, Arlette y Raysa, por ser ejemplo de perseverancia y superación.

A mi compañero, Fernando, por todo el apoyo, cariño y comprensión durante la elaboración de esta monografía.

A mi orientador Heraldo y mi coorientadora Michele, por su apoyo y ayuda.

A todos los amigos, colegas y profesores que me acompañaron durante este camino en la UFRGS, gracias por su paciencia, esfuerzo, dedicación y ayuda para llegar hasta aquí.

UNIVERSIDADE FEDERAL DO RIO GRANDE DO SUL
ESCOLA DE ENGENHARIA - CURSO DE ENGENHARIA MECÂNICA
TRABALHO DE CONCLUSÃO DE CURSO – 2021

ANALYSIS OF STATIC FORCES IN END MILLING OF TOOLOX® 44

KUNHARDT, Gretcheen Grichel Suazo

g.suazok@gmail.com

Abstract. *With the development of the industrial sector, the constant necessity to improve manufacturing processes and reduce production time while delivering higher quality products calls for engineers and researchers to develop new materials and alloys. This new material with improved conditions requires testing, analysis and validation of their properties and characteristics, as well as their performance and machinability. The purpose of this paper is to analyze and evaluate the active and passive static forces in dry and flood lubrication-assisted end milling of Toolox® 44 with different cutting conditions. An experiment using 3-factor Box Behnken design with three controllable cutting parameters (cutting speed, axial depth of cut, feed per tooth) was used to evaluate their influence on the measured forces. The analysis of variance showed that a_p was the most significant parameter. Multivariate regression analysis for parameter optimization suggests that for dry cutting, the lowest active and passive forces are obtain with $v_c = 90.70$ m/min, $f_z = 0.05$ mm/tooth and $a_p = 0.40$ mm. The best results for flood-lubricated milling are obtained with $v_c = 91.51$ m/min, $f_z = 0.05$ mm/tooth and $a_p = 0.46$ mm.*

Keywords: *Toolox® 44, end milling, static force, optimization.*

1. INTRODUCTION

With the evolution of the industry, the constant necessity to improve manufacturing processes and reduce production time while delivering higher quality products calls for engineers and researchers to develop new materials that can perform equally or better as those in the market. New materials and alloy are created to meet these specific technical criteria, such as Toolox® 44. It is a pre-hardened tool steel that presents high cleanliness, fatigue resistance, dimensional stability, and good machinability (SSAB, 2021). This advanced high-strength steel (AHSS) is delivered quenched and tempered to 45 HRC, hardness level usually used in die-casting molds. This property enables the material to maintain stable dimensions after machined without the necessity to perform heat treatment, thus reducing manufacture time considerably (HANSSON, 2009). Several machining processes may be used for processing this material; however, end milling allows the manufacture of complex geometries of dies and molds. In this process, the tool (milling cutter) moves in one direction while spinning, thus removing material from the workpiece that is fixed to the machine table (SOUZA, 2016).

According to Passari (2019), there are independent or controllable input variables that must be considered in the machining process. Among them are included workpiece material, tool material, tool geometry, cutting parameters, and machine-tool type. Although the input variables are independent, after defining the material and shape to be machined, tool geometry and material, and machine-tool, most of these variables are defined. To make the process more efficient, the variables that can be changed and have greater adaptability are the cutting parameters.

The main cutting parameters in end milling are axial depth of cut (a_p), radial depth of cut (a_e), cutting speed (v_c) and feed per tooth (f_z). Each of these parameters influences the machining process depending on the cutting operation and application. Their different combinations can result in significant changes in the process (PASSARI, 2019). The environment in which the operation occurs also influences the final product, especially due to the temperatures developed in the tool-part interfaces. The cutting operation can be performed under dry condition or with the aid of lubricooling techniques (SOUZA, 2016).

Souza (2016) also emphasizes that the main output dependent variables of the process are chip formation, machining force and power, vibration, temperature in the cutting zone, tool wear and machined surface finish. Among them, the knowledge of machining forces is important to assess the machinability of the material and the cutting tool life (TOH, 2004), as well as making it possible take actions that will provide stability to the process, thus extending both tool and machine lifespans.

This work aims to study the influence of the cutting parameters over the active and passive static forces in the end milling of Toolox® 44 under dry and wet machining conditions. The studied parameters will be cutting speed, axial depth of cut, and feed per tooth.

The analysis of this experiment can serve as ground to confirm the data informed by the manufacturer, identifying the applicability of the recommended working ranges for the end milling process and identifying the best cutting combination of the cutting parameters to obtain the lowest static force values.

2. MATERIALS AND METHODS

Toolox® 44 was the material used for the experiment (SSAB Oxelösund). According to the manufacturer inspection certificate, Table 1 presents the chemical nominal composition of the steel samples used.

Table 1 – Chemical nominal composition of Toolox® 44 (%wt).

C	Cr	Mo	Mn	Si	V	Ni	P	S
0.32	1.35	0.80	0.80	0.60-1.10	0.14	<1.00	<0.01	<0.002

Source: Ribeiro et al. (2021)

The dimensions of the workpiece of Toolox® 44 are 193 mm in length, 53 mm in height, and 115 mm in width, divided into 16 sections. Out of the 16 sections, 15 were utilized, leaving the remaining section as a backup. Figure 1 illustrates the test specimen design of the planned runs and fixation points of the experiment. In order to secure the material and prevent dislocation caused by vibration of the piece, the workpiece was fixed

by four Allen screws. The cutter was positioned 3 mm from the workpiece before each run.

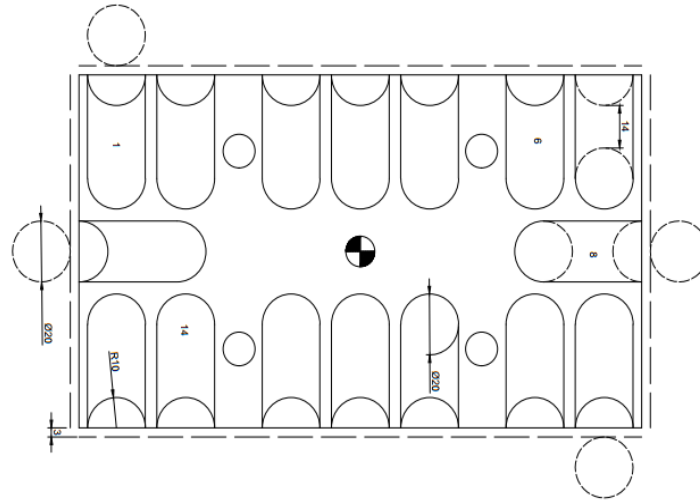

Figure 1 – Test specimen design with dimensions after machining.
Source: adapted from Ribeiro et al. (2021, p.2)

The machining tests were performed using two Walter Tools ADMT10T308R-F56 WKK25S PVD/TiAlN+Al₂O₃ coated carbide inserts ($r_\epsilon = 0.8$ mm). A new pair of inserts was used for each run, and the tool run-out was kept under 0,04 mm. Flank wear is lower than 0,1 mm.

The experiment was performed with a ROMI Discovery 308 machining center, located at Machining Automation Laboratory at UFRGS (LAUS). This machine-tool has a maximum spindle speed of 4000 rpm and maximum power of 5.5 kW. All dry-cutting runs were performed in the same face of the workpiece, with the flood-lubricated runs performed in the opposite face with Bondmann Química B90 oil-free bio-lubricant.

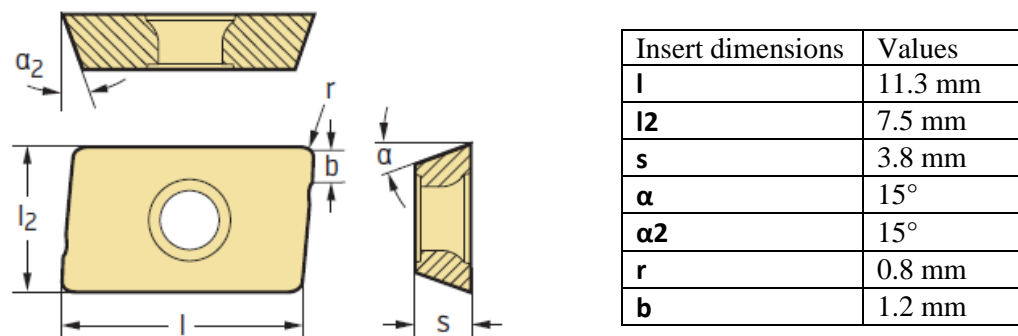

Figure 2 – Insert dimensions [Source: adapted from WALTER E.K., 2020]

To obtain the values of the machining force components (F_x , F_y , F_z), a system composed of a Kistler® 9129A piezoelectric dynamometer and a Kistler® 5070A10100A signal conditioner. The dynamometer is formed by four symmetrically distributed quartz

crystals that can measure force values at any position on the platform. The signal conditioning unit amplifies and filters the analog signal received from the dynamometer and converts the input electrical charge (pC) into electrical voltage (V) proportional to the implemented force (F). The analog signal is captured by the Measurement Computing® PCIM-DAS 1602/16 data acquisition board at sample rates varying from 2800 to 4700 points per second, depending on the spindle speed used. All force signals were processed in LabVIEW™9.0.

The cutting conditions used in each run were defined through a Box-Behnken Design of experiments (BBD). Box-Behnken Design based on the Response Surface Methodology (RSM). According to Ferreira et al. (2007), this method is based on three-level incomplete factorial designs. The combination of factors occurs through three levels: low (-1), central (0) and high (+1). The BBD has some advantages: it is more efficient than the three-level full factorial designs, and it is useful in avoiding experiments performed under extreme conditions, for which unsatisfactory results might occur. For a three-variable system, the number of experiments required is reduced to 12 (combinations of values through the three levels), with an additional number of 3 experiments with the central point values.

The sequence of the experiment was defined by the BBD, which combined the significance levels of the input parameters: cutting speed v_c [m/min], axial depth of cut a_p [mm], and feed per tooth f_z [mm/tooth]. The combinations of these parameters were randomized with statistical analysis software Minitab®21, resulting in different configurations of the levels presented in Table 2.

Table 2 – Cutting parameters and significance levels selected for the BBD.

Input parameters	Low	Central	High
Axial depth of cut a_p [mm]	0.4	0.8	1.2
Cutting speed v_c [m/min]	60	80	100
Feed per tooth f_z [mm/tooth]	0.05	0.075	0.1

3. RESULTS AND DISCUSSION

Table 3 presents the results of active and passive static forces for different combinations of cutting parameters for both dry and flood conditions. These forces were calculated from the values of the machining force components (F_x , F_y , F_z) measured with the Kistler® piezoelectric dynamometer.

The passive force is concentrated in the F_z component, while the active force occurs in the machining plane, according to Eq. (1):

$$F_t = \sqrt{F_x^2 + F_y^2} \quad (1)$$

The static portion of the active and passive force components corresponds to the average of their values over a defined period. The sections highlighted on the table are the midpoints or central point values determined via BBD. They are the only runs of the experiment whose control variable values are repeated, allowing to evaluate tendencies during the process. Figure 3 presents the measured active static force values for both dry and flood milling of Toolox® 44. Error bars for 95% confidence interval correspond to ± 1

standard deviation from the mean of the analyzed signal.

Table 3 – Static force portion for each section on dry and flood lubricated conditions.

Section	Control variables			Static force			
				Dry		Flood	
	v_c [m/min]	a_p [mm]	f_z [mm/tooth]	Active [N]	Passive [N]	Active [N]	Passive [N]
1	80	0.4	0.1	98.8	66.4	139.9	106.6
2*	80	0.8	0.075	177.3	60.2	218.3	83.9
3	60	0.8	0.1	215.8	83.6	259.1	91.3
4*	80	0.8	0.075	184.0	64.9	215.6	66.4
5	60	1.2	0.075	277.4	63.06	312.2	83.4
6	100	0.8	0.1	207.1	70.3	253.8	111.4
7	80	1.2	0.05	218.5	51.6	260.7	91.3
8	100	0.4	0.075	76.0	62.60	82.9	90.0
9	100	0.8	0.05	139.7	55.5	155.6	87.8
10	60	0.4	0.075	83.2	57.5	105.9	81.6
11*	80	0.8	0.075	184.2	58.5	212.3	76.4
12	60	0.8	0.05	148.2	73.4	167	85.7
13	100	1.2	0.075	284.3	123.3	328.7	96.2
14	80	0.4	0.05	71.21	54.7	89.3	80.6
15	80	1.2	0.1	325.5	92.7	375.7	101.8

* Three sections at central significance level of the controllable input parameters.

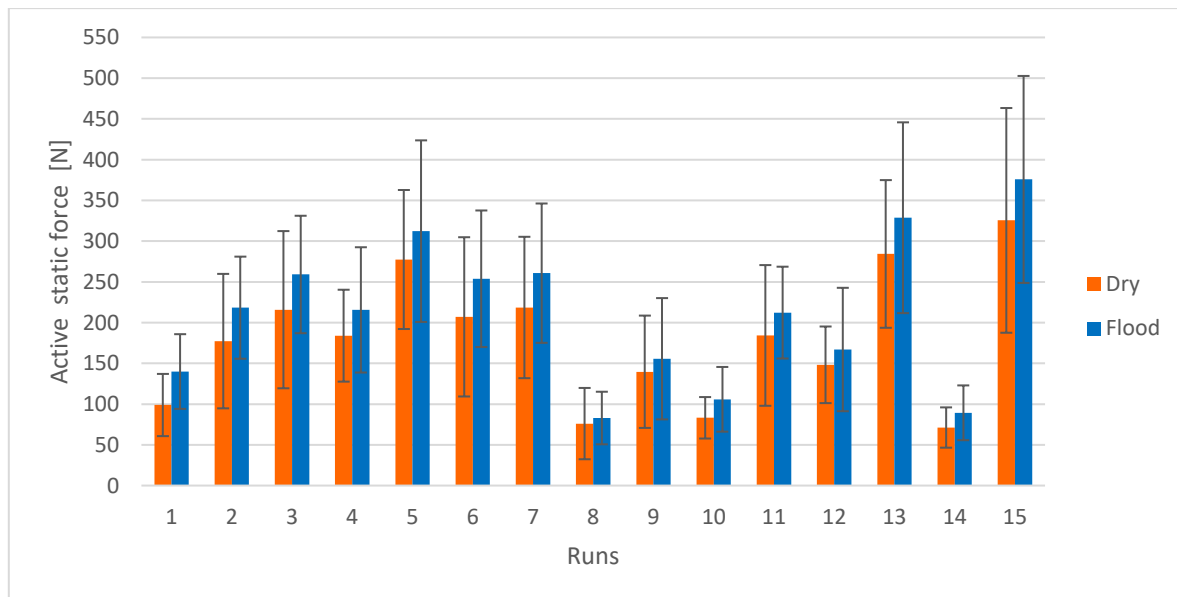

Figure 3 – Active force values for dry and flood milling of Toolox® 44.

The active forces observed in the wet are always higher than those observed in dry

machining. A probable cause is the cooling effect of the cutting fluid, that tends to reduce the material softness caused by the heat produced in the cutting process. According to Dikshit et al. (2017), the decrease in cutting force components occurs due to highly localized temperature, stresses and strain rates which decrease the chip thickness and lead to thermal softening of the workpiece material and greater amount of shear deformation.

Small dispersion was observed for the results obtained by the central points for both dry and wet machining. Also, the smallest force values were observed in both lubricooling conditions in runs (1, 8, 10 e 14) machined with the low level of axial depth of cut, $a_p = 0.4$ mm. The highest force values for both dry and flood lubricooling conditions were obtained in the machining of sample 15. Both depth of cut ($a_p = 1.2$ mm) and feed per tooth ($f_z = 0.1$ mm/tooth) for this section have the highest tested levels. Moreover, considering high active forces for high a_p , the values in runs 5 and 13 were similar. In this case, the v_c level was different (low and high levels, respectively), indicating that the cutting speed v_c effect was not important.

The passive static force values are plotted in Figure 4. Error bars for 95% confidence interval correspond to ± 1 standard deviation from the mean of the analyzed signal. Strong dispersion was observed for the machining of all samples. For central points, passive force values are lower in dry condition. A considerable increase in passive force can be observed in the flood lubrication for all conditions, except for section 13, where a higher passive force is observed for dry condition. In this section the cutting speed is ($v_c = 100$ m/min) and axial depth of cut is ($a_p = 1.2$ mm), the upper extreme values of the significance level of the experiment.

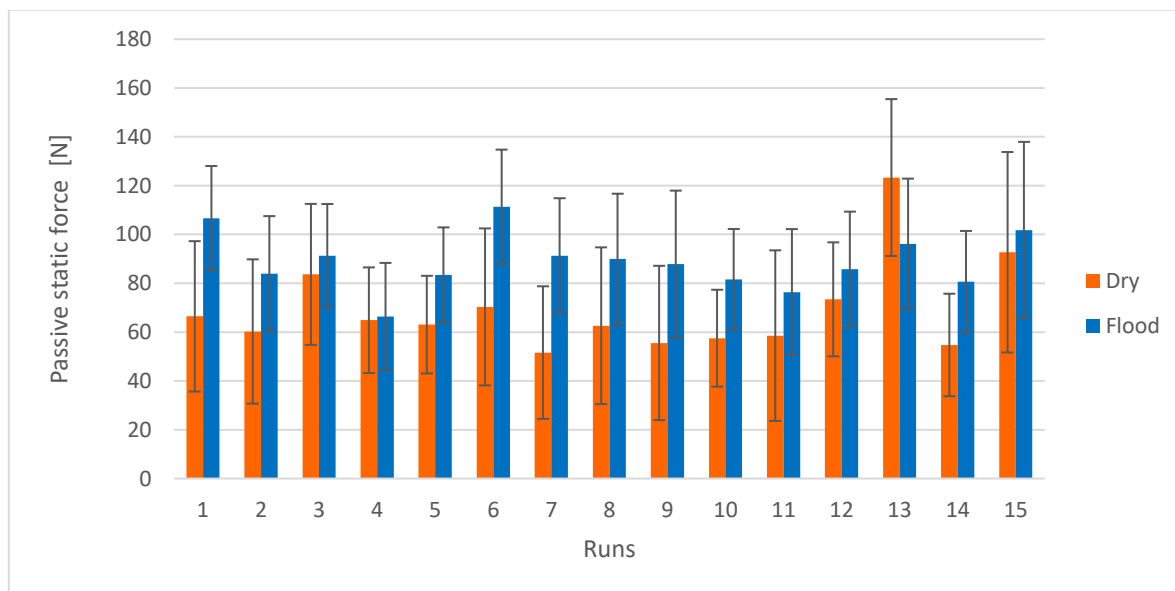

Figure 4 – Passive static force values for dry and flood milling of Toolox® 44.

Ding et al. (2010), in an experiment with AISI H13 steel (in dry condition) that investigate the effects of cutting parameters on cutting forces, comments that all cutting force components increase with the increasing of the cutting parameters. The same can be seen here in runs 13 and 15, but, in this analysis, the highest force values seem to be related to the upper extreme values of a_p when it is combined with another parameter in its maximum

value. It occurs in both scenarios of active force and only in dry scenario of passive force. Ding et al. (2010) also mentions that cutting forces increase with the increase in feed per tooth which means that radial depth of cut and axial depth of cut increase due to an increase in chip load. The author concludes that axial depth of cut, and feed are the two dominant cutting parameters that influence cutting forces.

3.1 Analysis of Variance – Active Static Force

The analysis of variance (ANOVA) of the data obtained experimentally allowed to determine the controllable variables that have the greatest influence on the response variables. For a confidence interval of 95%, p-values smaller than 0.05 indicate a significant influence of the control variable on the force values. Lower p-values indicate higher contribution of the control parameter on the result. Table 4 presents the ANOVA results of Active Static Force values for both lubricooling conditions. The most significant p-values are highlighted in bold.

Table 4 – ANOVA results for Active Static Force

Factor	Active Static Force			
	Dry		Flood	
	P-value	Contribution (%)	P-value	Contribution (%)
v_c	0.334	0.04	0.38	0.06
a_p	< 0.001	87.32	< 0.001	83.73
f_z	< 0.001	10.53	< 0.001	14.37
v_c^2	0.706	0.00	0.139	0.21
a_p^2	0.903	0.00	0.963	0.00
f_z^2	0.379	0.04	0.792	0.01
$v_c \times a_p$	0.284	0.06	0.068	0.35
$v_c \times f_z$	0.983	0.00	0.736	0.01
$a_p \times f_z$	0.001	1.82	0.013	0.94
<i>Error</i>	---	0.20	---	0.33
R^2	99.80%		99.67%	

Both machining conditions are highly correlated to the results, with R^2 of 99.80% for dry and 99.67% for flood machining. The same variables with the greatest influence on the results are maintained for both scenarios, with slight differences in the distribution of their contributions.

The most significant linear effect is depth of cut a_p , with 87.32% for dry and 83.73% for flood machining, following feed per tooth f_z (also linear effect), with 10.53% and 14.37%, respectively; finally, the influence of the interaction between $a_p \times f_z$ with 1.82% and 0.94%.

3.2 Analysis of Variance – Passive Static Force

Table 5 presents the ANOVA results of passive static force values in both lubricooling conditions. The most significant p-values are highlighted in bold.

Table 5 – ANOVA results for Passive Static Force

Factor	Passive Static Force			
	Dry		Flood	
	P-value	Contribution (%)	P-value	Contribution (%)
v_c	0.519	3.00	0.043	12.31
a_p	0.129	20.61	0.428	1.27
f_z	0.175	15.61	0.010	28.27
v_c^2	0.325	6.96	0.118	3.45
a_p^2	0.569	2.36	0.075	6.21
f_z^2	0.969	0.01	0.007	32.32
$v_c \times a_p$	0.174	15.67	0.717	0.25
$v_c \times f_z$	0.901	0.11	0.176	4.24
$a_p \times f_z$	0.438	4.44	0.232	3.15
Error	---	31.24	---	8.53
R^2	68.76%		91.47%	

Unlike active force analysis, the passive force presented a R^2 of 68.76% for dry machining, with the error being the highest contribution (31.24%). This may have occurred due to dry scenario modeling not considering all significant input parameters to better model passive force behavior. Some intrinsic disturbance to the milling process such as vibration can have a high influence on error percentage since dry machining occurs in a more unstable condition.

In flood condition, the value of R^2 increases to 91.47%, demonstrating that error can be neutralized by a smoother contact between surfaces. Therefore, it can be considered an appropriate model to determine the process significant variables. In this case, the relevant factor is feed per tooth and its quadratic and linear effect (with a contribution of $f_z = 32.32\%$ e $f_z^2 = 28.23\%$, respectively), followed by the linear effect of cutting speed v_c , with a contribution of 12.31%.

3.3 Contour Surface Plots

Contour plots were generated for central level parameters with the greatest contribution to the force value in each scenario. For active force $a_p = 0.8$ mm was used (Figure 5a) and for passive force (Figure 5b) $f_z = 0.075$ mm/tooth was used.

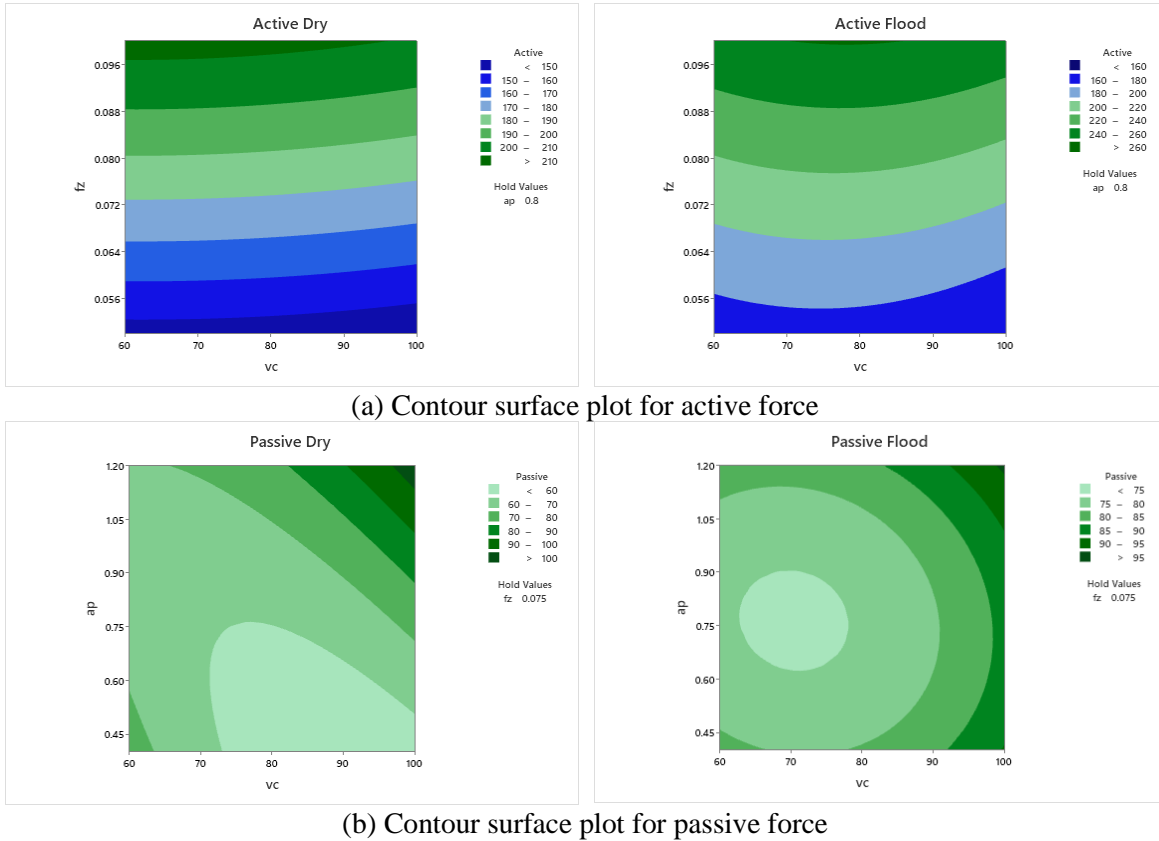

Figure 5 – Contour surface plots.

Figure 5a demonstrates that for dry machining, active force varies considerably with small intervals of feed per tooth f_z , while in lubricated milling there are no such drastic variations, which allows for more constant ranges of force values. Cutting speed v_c contribution appears to occur in a more subtle and linear way for dry condition while flood lubrication presents lower force values for v_c extreme values, suggesting a quadratic behavior.

It can be verified in Figure 5b that in dry condition the value interval of $a_p \leq 0.75$ mm and $v_c > 70$ m/min shows the lowest values of passive force. However, ANOVA analysis for this scenario indicates a 31.24% error, which does not allow considering the contour graph reliable. Flood milling ANOVA with R^2 of 91.47% in contrast, points out an optimal range for lowest passive values considering $a_p \leq 0.90$ mm and $60 < v_c \leq 75$ m/min.

3.4 Parameter Optimization

Figures 6 and 7 demonstrate the characteristic curves of each input variable for passive and active force. Curves superposition behavior is also indicated by marking optimized input parameters in red vertical lines. Response values prediction is indicated by a blue horizontal dashed line.

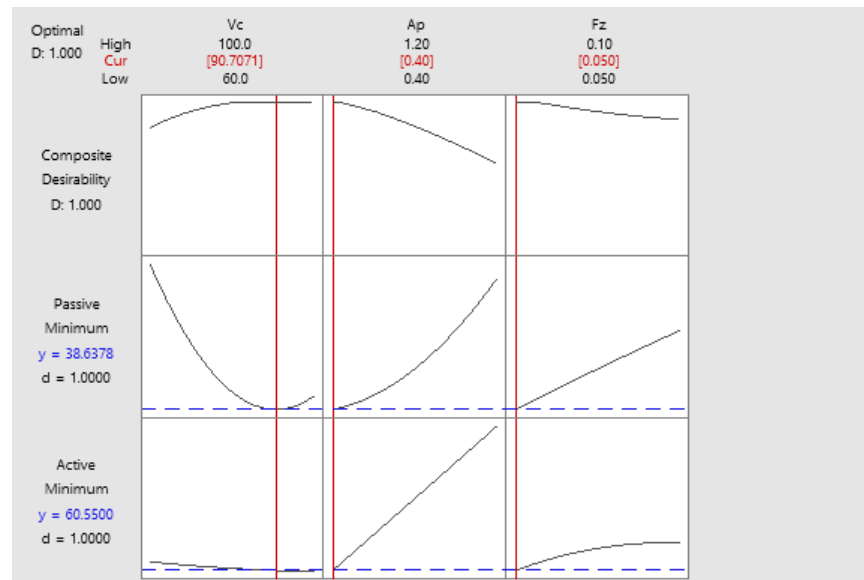

Figure 6 – Dry condition

For dry machining, the optimized values are the lowest a_p e f_z significance levels selected for the BBD and between the central and high values for v_c . This last variable is the one with the most divergent behaviors between active and passive force, reminding that passive force ANOVA was not shown to be reliable only with these 3 parameters. Active force ANOVA for dry milling points out a_p as the most relevant parameter, and its curve presents linear and uniform behavior.

The input variables values that generate the best combination of response variables are: $v_c = 90.70$ m/min, $f_z = 0.05$ mm/tooth and $a_p = 0.40$ mm. The projected values for the response variables are passive force = 38.63 N and average force = 60.55 N.

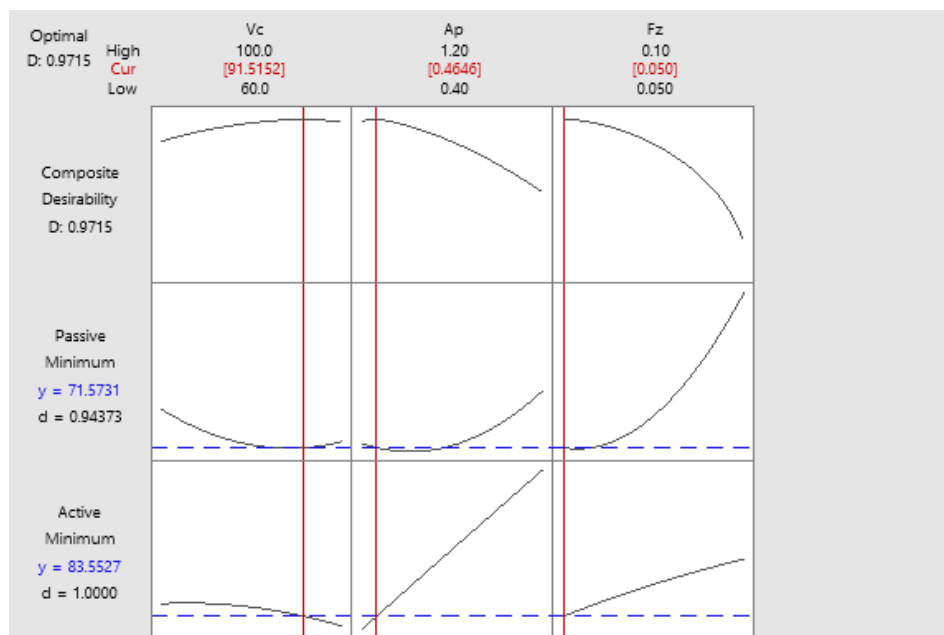

Figure 7 - Flood condition

For flood milling, optimization by the lowest significance levels selected for the BBD only occurs at f_z . For a_p , value is closer to the lowest and for v_c it is between central and highest significance level. The three variables have different behaviors between active and passive modelling. In passive force ANOVA, f_z and its quadratic effect are the most relevant variables; the quadratic effect is shown by its curve behavior. For active force ANOVA, a_p has the greatest contribution to the result. As in dry machining, it shows a linear and uniform behavior.

The input variables values that generate the best combination of response variables are: $v_c = 91.51$ m/min, $f_z = 0.05$ mm/tooth and $a_p = 0.46$ mm. The projected values for the response variables are passive force = 71.57 N and active force = 83.55 N.

Ribeiro et al. (2021) studied the influence of the machining parameters on the surface finish in dry and wet end-milling of Toolox® 44. Aiming to explain the fluctuations observed for the passive forces, the results of these components were compared with the surface roughness for each run. The authors identified lower roughness values in dry machining for most runs. However, the analysis of the roughness profiles showed a more pronounced waviness in dry cutting. It was not possible to find a clear correlation, but the waviness could indicate the occurrence of vibrations.

4. CONCLUSION

The Box-Behnken Design of experiments was used for the analysis of the influence of the cutting parameters on active and passive forces in the end milling of Toolox® 44 steel. Using analysis of variance (ANOVA) to evaluate active and passive force in dry and flood milling, some tendencies in force behavior were identified. In both scenarios, the parameter that has the most significant influence on active force values is the depth of cut a_p . However, a_p contribution is more relevant in dry machining, while there is a more representative influence of the feed per tooth in flood machining.

For passive force, in flood lubrication the contribution of the selected cutting parameters presented stability for the machining process, culminating in an ANOVA with relevant variables. In this situation the contact between surfaces is smoother than in the dry condition, reducing vibrations and the contribution of errors observed in dry machining. Feed per tooth was the variable with the most significant influence on the passive force, which can be explained based on the passive force being in the same direction of the tool's rotation axis.

Based on the experimental results, the scenario that seems most suitable for the end milling of Toolox® 44 steel is flood stat. Although it does not present the lowest force values, this condition demonstrates more suitable stability, as can be seen in the analysis of its active force levels. In addition, the ANOVA error percentages in the dry cutting for passive force do not allow choosing this scenario, presuming that other variables influence the process.

5. REFERENCES

DIKSHIT, M.K, PURI, A.B. MAITY, A. (2017) “**Modelling and application of response surface optimization to optimize cutting parameters for minimizing cutting forces and surface roughness in high-speed, ball-end milling of Al2014-T6**”. The Brazilian Society of Mechanical Sciences and Engineering, Vol. 39, pp. 5117-5133.

DING, T., ZHANG, S., WANG, Y., ZHU, X., (2010) “**Empirical models and optimal cutting parameters for cutting forces and surface roughness in hard milling of AISI H13steel**”. The International Journal of Advanced Manufacturing Technology, Vol. 51, pp. 45-55.

S.L.C. FERREIRA, R.E. BRUNS, H.S. FERREIRA, G.D. MATOS, J.M. DAVID, G.C. BRANDÃO, E.G.P. DA SILVA, L.A. PORTUGAL, P.S. DOS REIS, A.S. SOUZA, W.N.L. DOS SANTOS, (2007) “**Box-Behnken design: An alternative for the optimization of analytical methods**”. Analytica Chimica Acta, Vol. 597, Issue 2, pp. 179–186.

HANSSON, P. (2009) “**Modern Pre-hardened Tool Steels in Die-Casting Applications**”. Materials and Manufacturing Processes, Vol. 24, pp. 824–827.

PASSARI, E. S., (2019) “**Otimização dos parâmetros de fresamento frontal em aço Hardox®450 baseada na rugosidade e na força resultante**”. Trabalho de Conclusão de Curso em Engenharia Mecânica – Departamento de Engenharia Mecânica, Escola de Engenharia, Universidade Federal do Rio Grande do Sul, Porto Alegre.

RIBEIRO, M. B. A., SOUZA, A. J., AMORIM, H. J. (2021) “**Investigation of surface roughness generated by end milling of Toolox 44®**”, COBEM2021-0118

SOUZA, A. J., (2016) “**Apostila ENG03343 – Processos de Fabricação por Usinagem**”, Departamento de Engenharia Mecânica, Escola de Engenharia, Universidade Federal do Rio Grande do Sul, Porto Alegre.

SSAB (2021) “**Toolox® - Easy-to-machine steel**”, Available at: <https://www.ssab.com.br/products/brands/toolox/workshop-friendly>.

TOH, C. K. (2004) “**Static and dynamic cutting force analysis when high speed rough milling hardened steel**” Materials and Design Vol. 25, pp. 41–50.

WALTER E.K. (2020) “**Catálogo de inovações e produtos**” pp. 186, Available at: <https://walterstrgprod.blob.core.windows.net/files/sitecollectiondocuments/downloads/global/catalogues/pt-pt/product-innovations-2020-2-orderpages-pt.pdf>