



KARINA BOHRER DO AMARAL

BIOGEOGRAFIA HISTÓRICA DOS GOLFINHOS DELPHININAE
(CETARTIODACTYLA:DELPHINIDAE)

Dissertação apresentada ao Programa de Pós-Graduação
em Biologia Animal, Instituto de Biociências da Universidade
Federal do Rio Grande do Sul, como requisito parcial à
obtenção do título de Mestre em Biologia Animal.

Area de Concentração: Biologia Comparada – Sistemática e Biogeografia

Orientador: Prof.Dr.Ignacio Benites Moreno

UNIVERSIDADE FEDERAL DO RIO GRANDE DO SUL
PORTO ALEGRE
2014

BIOGEOGRAFIA HISTÓRICA DOS GOLFINHOS DELPHININAE
(CETARTIODACTYLA:DELPHINIDAE)

KARINA BOHRER DO AMARAL

Aprovada em 20 de março de 2014.

Dr. Ewan Fordyce

Geology Department, Otago University, Nova Zelândia.

Dra. Ana Rita Amaral

Centre for Environmental Biology

Faculdade de Ciências, Universidade de Lisboa, Portugal.

Dr. Augusto Ferrari

Laboratório de Entomologia Sistemática - Departamento de Zoologia

UFRGS - Universidade Federal do Rio Grande do Sul.

*Apesar das ruínas e da morte
Onde sempre acabou cada ilusão
A força dos meus sonhos é tão forte
Que de tudo renasce a exaltação
E nunca minhas mãos ficam vazias.
(Sophia de Mello Breyner Andresen)*

Dedico este trabalho, com todo meu amor,
respeito e admiração,
aplicando tudo que aprendi com ele,
ao melhor amigo,
Meu pai.

AGRADECIMENTOS

Ao se concluir esta etapa, faz-se necessário agradecer:

- à minha família, em especial à minha mana querida (Caroline) por ser meu melhor exemplo, aos meus pais pelo amor, carinho, segurança e apoio;
- à família Labsmar, em especial: Sophie, Jana, Elisa, Dandara e aos “maninhos de mestrado”: Sil e Derek;
- aos professores do PPGBAN/UFRGS, em especial ao Prof. Dr. Augusto Ferrari pelas significativas contribuições que foram fundamentais para execução do trabalho;
- aos amigos e colegas do PPGBAN/UFRGS, em especial a Valentina Zaffaroni e o Filipe Michels Bianchi;
- aos “amigos orientadores”: Juliano Boldo, Charley & Livia, Dani Danilewicz, Larissa Heinzelmann;
- em especial, ao Prof. Ignacio, pela orientação, confiança, dedicação, conselhos de vida e, principalmente, a amizade.

SUMÁRIO

RESUMO.....	8
APRESENTAÇÃO	9
CAPÍTULO 1	10
EVOLUÇÃO DOS CETÁCEOS.....	10
DELPHININAE	16
Histórico e relações filogenéticas	16
Distribuição das espécies do clado Delphininae	24
Análise Espacial de Vicariância	30
REFERÊNCIAS.....	32
ORIGINAL ARTICLE	38
Historical biogeography of Delphininae dolphins (Cetartiodactyla: Delphinidae)	38
INTRODUCTION.....	39
MATERIAL AND METHODS.....	49
Data selection	49
Morphological hypothesis	49
Molecular hypothesis.....	50
Distribution Data.....	50
Biogeographical Analysis.....	51
RESULTS	52
Distribution Data.....	52
Biogeographical Analysis.....	54
Morphological data.....	54
Molecular data.....	56
DISCUSSION.....	58
Delphininae origins – how the morphological and molecular phylogenetic hypothesis could help us?	58
The Benguela Upwelling System – only one gate or the main barrier of the tropical oceans?	64
<i>Leucopleurus acutus</i> – incertae sedis or a Delphininae member?.....	68
Southwest Atlantic Ocean (SWA) – An important endemism area?	70

General considerations	74
REFERENCES	75
CONSIDERAÇÕES FINAIS	82
ANEXO 1 (APPENDIX 1)	83
ANEXO 2	120

RESUMO

Delphinidae é a família de cetáceos mais diversa dentre os cetáceos atuais e o agrupamento dos gêneros em subfamílias foi inicialmente baseado na semelhança de caracteres morfológicos. Na primeira análise cladística para o clado Delphinidae, baseada em dados de citocromo *b*, quatro subfamílias foram propostas. Nesta primeira análise, sugeriu-se que os gêneros *Delphinus*, *Tursiops*, *Stenella*, *Lagenodelphis* e *Sousa* deveriam ser incluídos no clado Delphininae. Estudos subsequentes baseados em dados moleculares e morfológicos diferem nas relações propostas entre as espécies e na inclusão do gênero *Sousa* no clado Delphininae. Devido à incongruência entre as relações filogenéticas baseadas tanto na morfologia quanto em dados de DNA mitocondrial e nuclear, foi proposta a inclusão de todas as espécies pertencentes à subfamília para o gênero *Delphinus*, sob a justificativa de que a atual taxonomia não reflete a real história evolutiva do grupo. É consenso que a radiação de Delphininae foi um evento rápido e recente iniciado no Plioceno, no qual a divergência das espécies ocorreu ao longo do Pleistoceno. Para compreender os processos envolvidos na evolução de Delphininae, à luz da biogeografia histórica, foi utilizado o método da “*Spatial Analysis of Vicariance*”, cuja principal meta é identificar taxóons-irmãos com distribuições disjuntas. “*Spatial Analysis of Vicariance*” (SAV) foi conduzida no “*Vicariance Inference Program*” (VIP) a partir de duas hipóteses filogenéticas, uma construída a partir de dados moleculares e outra de dados morfológicos. A partir de revisão exaustiva da literatura, 2.637 registros de ocorrência de todos os taxa terminais pertencentes à Delphininae e grupos externos foram compilados. A busca por distribuições disjuntas entre grupos filogeneticamente relacionados foi conduzida através de 1.000 iterações. A grade de células utilizada foi 2°x2° com preenchimento máximo ajustado para 1. O custo atribuído para a remoção total da distribuição do terminal foi 1 e o custo de uma remoção parcial foi ajustado para 0,75. Não foi utilizado percentual de sobreposição. Em ambas análises de vicariância realizadas tanto com dados moleculares quanto morfológicos, foram recuperados eventos vicariantes e diferentes cenários biogeográficos foram hipotetizados. A separação entre Delphininae e Steninae parece estar relacionada ao soerguimento do Istmo do Panamá que ocorreu há 7 – 3,5 Ma e teve grande importância na fragmentação da biota marinha entre os oceanos Pacífico e o Atlântico. As disjunções encontradas em táxons terminais estão principalmente relacionadas à Corrente de Benguela e, também a Barreira do Pacífico Oriental. A corrente de Benguela é um importante sistema de ressurgência dos oceanos, sendo um dos mais produtivos ecossistemas do mundo, cuja oscilação da temperatura, a partir de 3 Ma atrás, promoveu a fragmentação da fauna marinha tropical durante períodos frios, mas permitiu o intercâmbio de faunas entre o Atlântico e o Índico durante períodos mais quentes. Os demais eventos vicariantes encontrados parecem estar relacionados à fragmentação do ambiente costeiro no Atlântico e Indo-Pacífico durante os períodos glaciais e interglaciais do Pleistoceno.

APRESENTAÇÃO

Esta dissertação de mestrado está sendo apresentada conforme Resolução N° 23/2009 do Programa de Pós-Graduação em Biologia Animal (PPGBAN) da Universidade Federal do Rio Grande do Sul (UFRGS).

A dissertação inicia com capítulo introdutório, onde consta um breve histórico das relações filogenéticas do grupo de estudo, seguido pela revisão da distribuição das espécies abordadas e uma breve descrição da metodologia utilizada e os principais resultados. Em seguida, apresenta-se o artigo científico, redigido em inglês, que é a principal parte da dissertação onde os assuntos são abordados de forma mais profunda. Ao final, constam as considerações finais e os anexos que complementam as informações do artigo científico e as regras do periódico no qual se baseou a formatação da dissertação.

O periódico escolhido foi o *Journal of Biogeography*, publicação mensal da *Wiley-Blackwell*, cujas normas estão no material em anexo, conforme a resolução do PPGBAN-UFRGS.

CAPÍTULO 1

EVOLUÇÃO DOS CETÁCEOS

Nos últimos 20 anos, muitos estudos tentaram esclarecer as relações de parentesco entre artiodáctilos e cetáceos que por muito tempo estiveram em ordens distintas (Artiodactyla e Cetacea, respectivamente). Análises moleculares e morfológicas indicam que os cetáceos são grupo-irmão dos hipopotamídeos (Fordyce, 2003; Price *et al.*, 2005). Desta forma, a partir dos últimos anos, artiodáctilos e cetáceos foram unidos na superordem Cetartiodactyla (Price *et al.*, 2005; Agnarsson & May-Collado, 2008).

Os cetáceos são o grupo de mamíferos marinhos mais adaptados à vida aquática e são popularmente conhecidos como baleias, botos e golfinhos (Barnes, 2002). Apesar de serem bastante diversos, existindo atualmente cerca de 89 espécies (Steeman *et al.*, 2009), e estarem amplamente distribuídos no ambiente marinho, ocupando águas que variam de rasas a profundas e de tropicais a polares sendo encontrados também em sistemas de água doce, os cetáceos são um grupo monofilético cuja origem remonta ao Eoceno (50 Milhões de anos atrás) nas águas rasas e tropicais do extinto mar de Tethys (Figura 1) (Fordyce & Muizon, 2001; Fordyce, 2002a, 2003).



Figura 1 Configuração dos continentes no Eoceno há 50 milhões de anos. Seta indica o agora extinto mar de Tethys, local em que no Eoceno médio houve a diversificação dos arqueocetos. Fonte: <http://jan.ucc.nau.edu/~rcb7/globaltext2.html>.

A história evolutiva dos cetáceos é marcada por um longo e informativo registro fóssil obtido de muitas localidades (Barnes, 1990; Fordyce & Muizon, 2001). A partir do registro fóssil, observou-se que a evolução dos cetáceos foi marcada por três grandes radiações e, além disso, através dos fósseis é possível estimar a idade mínima das formas atuais e as origens das estratégias ecológicas que caracterizam os diferentes grupos vivos (Fordyce & Muizon, 2001).

A primeira radiação dos cetáceos ocorreu no início do Eoceno e foi realizada por cetáceos conhecidos como Archaeoceti (Fordyce, 2003). Os arqueocetos atualmente são todos animais extintos, mas estão divididos em cinco famílias que variam desde táxons pequenos, possivelmente anfíbios, com membros posteriores funcionais e apenas encontrados no mar de Tethys (ex. *Pakicetidae*), até táxons de grande porte, amplamente dispersos, obrigatoriamente marinhos com formas mais semelhantes aos grupos modernos, pertencentes à família *Basilosauridae* (Fordyce & Muizon, 2001). A radiação dos cetáceos foi marcada por um rápido aumento na variação do design básico (disparidade), indicando assim parcionamento ecológico (Fordyce, 2003) e invasão do litoral ao “ecoespaço” nerítico, que nunca havia sido utilizado por mamíferos carnívoros (Fordyce & Muizon, 2001). Já no Eoceno tardio a disparidade e a diversidade dos arqueocetos diminuíram e os basilosaurídeos passaram a ocupar latitudes temperadas (Fordyce, 2003).

A segunda maior radiação dos cetáceos marca o surgimento do grupo Neoceti na transição entre o Eoceno e Oligoceno há cerca de 33 Ma (Fordyce & Muizon, 2001; Fordyce, 2003). Neoceti é um grupo monofilético formado pelas duas superfamílias de cetáceos atuais *Odontoceti* e *Mysticeti*, que provavelmente evoluíram dos arqueocetos basilosaurídeos (Barnes, 1990; Fordyce & Muizon, 2001; Steeman *et al.*, 2009).

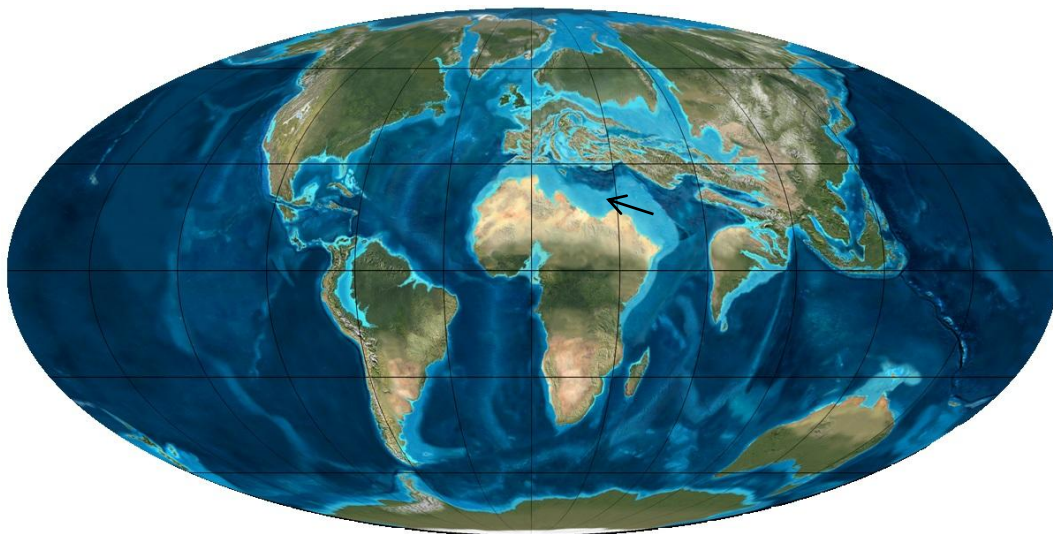
A evolução dos odontocetos e misticetos foi influenciada grandemente por eventos do Eoceno tardio e Oligoceno, como a reestruturação oceânica associada com a quebra da

Gondwana, a abertura do Oceano Glacial Antártico, o desenvolvimento do gelo antártico e mudanças climáticas globais. A consequência desses fatores ambientais para a evolução destes animais foi uma radiação precoce e dramática, levando a formação de uma alta diversidade de formas (Fordyce, 2003), relacionadas principalmente com o desenvolvimento de estruturas especializadas para a alimentação (Fordyce & Muizon, 2001).

Os odontocetos mantiveram o tipo primitivo de alimentação, semelhante ao dos arqueocetos, que consiste da seleção e captura de presas individuais e desenvolveram a ecolocalização. Em contraste, os mysticetos desenvolveram um método de filtração de um grande volume de água (Barnes, 1990). Portanto, este segundo evento de radiação marca a invasão total dos cetáceos modernos ao oceano aberto, uma vez que estas formas inovadoras de alimentação proporcionaram a invasão de novos ambientes, como a alimentação por filtração dos mysticetos tornou possível à ocupação das regiões polares e os odontocetos foram capazes de capturar presas abaixo da zona fótica com auxílio da ecolocalização (Fordyce & Muizon, 2001).

A terceira radiação dos cetáceos ocorreu no Mioceno tardio há cerca de 10-12 Ma, onde o grupo Delphinoidea (golfinhos e seus relativos) se diversificou e tornou-se o grupo com o maior número de espécies dos mares modernos (Fordyce & Muizon, 2001; Fordyce, 2003). Esta última radiação revela uma rápida diversificação dos grupos modernos e concomitante declínio das formas arcaicas (Fordyce & Muizon, 2001). Porém, o registro fóssil sugere que há cerca de 30 Ma quatro grandes clados já estavam bem estabelecidos dentro de Odontoceti: Physeteroidea, Platanistidae, Ziphiidae e Delphinida (Steehan *et al.*, 2009). Delphinida é uma superfamília que anterior a esta última radiação apresentava pouca diversificação, porém a partir de 11 Ma de anos, durante este terceiro evento de radiação o grupo sofreu um rápido processo de especiação e, atualmente, encontra-se composto por três famílias Delphinidae, Phocoenidae e Monodontidae (Steehan *et al.*, 2009).

Delphinidae é a mais diversa família de cetáceos existentes e apresenta uma variedade de formas de crânio, dentes e adaptações corporais que refletem suas dietas variadas e métodos de locomoção sendo, portanto, animais ecologicamente versáteis (Barnes, 1990; Steeman *et al.*, 2009). Esta é a família de golfinhos que apresenta o maior número de espécies de mamíferos marinhos, atualmente existindo 37 espécies reconhecidas/válidas (Caballero *et al.*, 2008). Os delfínidos são altamente diversos em águas tropicais e em latitudes quentes a temperadas, onde são encontrados diversos gêneros: *Delphinus*, *Sotalia*, *Sousa*, *Stenella*, *Steno*, *Tursiops*. Outros gêneros, como *Cephalorhynchus*, *Globicephala*, *Lagenorhynchus* e *Lissodelphis* são encontrados em águas mais frias (Leduc, 2002).

A partir destas considerações pode-se perceber que os cetáceos não seguiram um padrão evolutivo aleatório, sendo reconhecidas fases de evolução e extinção marcadas por dramáticas mudanças taxonômicas e/ou diversidade ecológica (Fordyce & Muizon, 2001). Para os grupos atuais de cetáceos está bem estabelecido que a distribuição das espécies relaciona-se intimamente tanto com características hidrográficas, quanto com características fisiográficas dos oceanos. Estes dados oceanográficos são os principais delimitadores das espécies de presas e conseqüentemente da distribuição dos cetáceos, uma vez que o habitat é primariamente delimitado pela disponibilidade de alimento (Baumgartner *et al.*, 2001; Forcada, 2002). Portanto, a estrutura, comportamento e distribuição global de muitos cetáceos vivos está fortemente ligada a disponibilidade de alimento e, por sua vez, massas de água e padrões climáticos globais. Relações similares podem ser inferidas para os cetáceos fósseis, baseados em padrões de diversidade e disparidade, além da evolução dos principais complexos funcionais (Fordyce, 2003).

Esclarecer as forças evolutivas que guiaram a radiação dos cetáceos apresenta algumas dificuldades, conhecidas como o “paradoxo marinho de especiação” (Bierne *et al.*, 2003). No ambiente marinho, existem poucas barreiras geográficas óbvias, muitas vezes a

distribuição dos organismos ainda não está bem estabelecida e os oceanos são tridimensionalmente contínuos. Além disso, muitas espécies marinhas apresentam ampla e rápida dispersão e assume-se que as correntes e passagens oceânicas permitem uma constante mistura de *pools* gênicos, inibindo mudanças evolutivas. Assim, o requerimento de isolamento durante especiação alopátrica parece ser mais difícil de ser satisfeito nos oceanos (Steehan *et al.*, 2009), embora a especiação também possa ocorrer em simpatria.

Steehan *et al.* (2009) sugerem uma hipótese para a moderna diversidade dos cetáceos, atribuindo-a, em parte, à rápida radiação adaptativa seguida da transição para uma zona adaptativa aberta logo no início da história dos cetáceos, quando Mysticeti e Odontoceti adquiriram suas respectivas habilidades de alimentação por filtração e ecolocalização respectivamente. Essa transição para uma região não ocupada do nicho ecológico está frequentemente associada a uma rápida mudança fenotípica, que leva ao aumento da disparidade estrutural, e assim, a diversificação das espécies devido ao relaxamento das restrições ecológicas e exploração de espaços insaturados do nicho ecológico durante as fases iniciais da radiação. Essas oportunidades ecológicas surgem quando recursos são abundantes e existem poucas linhagens competidoras presentes, tais oportunidades desencadeiam a explosiva diversificação das espécies durante os eventos de radiação.

Nos casos de rápida radiação, as barreiras intrínsecas que previnem o fluxo gênico entre as espécies podem não ter tempo suficiente para se desenvolver, levando a hibridização entre linhagens recentemente evoluídas. E, a existência de eventos de hibridização na história evolutiva de um grupo significa que tal táxon não seguirá o processo esperado de divergência a partir de um ancestral comum, dificultando a determinação das relações filogenéticas deste grupo com os demais (Amaral *et al.*, 2012a).

O objeto de estudo deste trabalho são os golfinhos da subfamília Delphininae. Esta subfamília exemplifica os desafios de inferir o limite do que é uma espécie e suas relações

filogenéticas. A discordância entre caracteres morfológicos e moleculares, devido aos rápidos e bem recentes eventos de especiação do grupo e a existência de poucos e consistentes caracteres morfológicos entre outros problemas, como o “paradoxo marinho de especiação”, dificultam a construção de hipóteses filogenéticas (Amaral *et al.*, 2012a).

Assim como ocorre para a família Delphinidae, existem muitas dúvidas a cerca das relações evolutivas dentro de Delphininae. A maior parte dos estudos que tenta esclarecer estas relações está baseada em métodos filogenéticos que muitas vezes não são capazes de capturar a complexa natureza evolutiva do DNA dos cetáceos, tendo como consequência resultados pouco esclarecedores (Leduc *et al.*, 1999; Leduc, 2002; McGowen *et al.*, 2009; McGowen, 2011; Amaral *et al.*, 2012a). Tais estudos ainda não chegaram a um consenso a respeito de quais espécies compõe a subfamília Delphininae além de outros problemas, como a monofilia e as relações de parentesco dos gêneros que a compõe.

Alguns gêneros pertencentes à subfamília Delphininae, como *Delphinus* e *Tursiops*, possuem representantes fósseis com cerca de cinco Ma, enquanto que *Stenella* apresenta fósseis de cerca 2 Ma (Barnes, 1990; Fordyce, 2002a). Estas espécies, assim como muitas outras, tiveram sua origem durante um evento explosivo de especiação que ocorreu no Plioceno, época que compreende a faixa de tempo entre dois e cinco milhões de anos atrás (Soligo *et al.*, 2005).

Ao longo dos 50 milhões de anos que compreendem a história evolutiva dos cetáceos, ocorreram inúmeras mudanças geográficas, climáticas e geológicas que incluem o fechamento e abertura de passagens ou bacias oceânicas, oscilações do ambiente costeiro devido a variações do nível do mar, alterações no sistema de correntes, ressurgências, massas de água latitudinais e regimes de temperatura oceânica. Essa evolução física dos oceanos provavelmente influenciou a evolução dos cetáceos em muitos aspectos, e a distribuição dos

cetáceos fósseis e modernos indica o importante papel da geografia na evolução destes animais (Fordyce, 2002b).

O Plioceno foi um período de intensas mudanças globais climáticas, geológicas e oceanográficas e coincide com a última radiação explosiva dos delfinídeos, o que pode sugerir que as mudanças que ocorreram neste período podem ter de alguma forma induzido esta radiação. Dentre os principais fenômenos que ocorreram neste período, pode-se citar o fechamento completo do istmo do Panamá no início do Plioceno (Soligo *et al.*, 2005), a média da temperatura global era cerca de 3 graus acima da média atual e o nível do mar estava aproximadamente 25 metros acima do nível atual (Fedorov *et al.*, 2006; Pastene *et al.*, 2007). Posterior a este aquecimento, há cerca de três Ma de anos iniciou-se a glaciação no hemisfério norte, e a partir deste período seguiu-se um ciclo de drásticas oscilações entre prolongadas glaciações ou eras do gelo e breves períodos interglaciais mais quentes. Durante os períodos interglaciais, incluindo o que estamos vivenciando atualmente e que começou em torno de 10 mil anos atrás, as condições se aproximam do que existiu na fase inicial do Plioceno (Fedorov *et al.*, 2006).

A extinção e/ou mudanças da distribuição de alguns táxons atestam significativas mudanças na ecologia dos cetáceos durante o Plioceno e, as principais mudanças dizem respeito ao resfriamento global e as mudanças da circulação oceânica (Fordyce *et al.*, 2002).

DELPHININAE

Histórico e relações filogenéticas

Desde os primeiros estudos baseados em morfologia reconhece-se Delphinidae como um agrupamento natural (Flower, 1883; True, 1889), mas as relações evolutivas entre as espécies ainda não estão bem estabelecidas mesmo depois de 130 anos de estudos. O agrupamento dos gêneros em subfamílias foi proposto, inicialmente, através de semelhanças em caracteres morfológicos (True, 1889; Fraser & Purves, 1960; Kasuya, 1973; Mead, 1975).

A partir destes primeiros estudos, as espécies eram incluídas em determinadas subfamílias de acordo com suas semelhanças morfológicas em relação aos seguintes gêneros *Delphinus* (Delphininae), *Steno* (Steninae), *Lissodelphis* (Lissodelphinae), *Cephalorhynchus* (Cephalorhynchinae) e *Globicephala* (Globicephalinae) (Fordyce *et al.*, 2006).

Dentre as subfamílias de Delphinidae, a resolução das relações filogenéticas das espécies pertencentes à Delphininae é ainda amplamente debatida (Kingston *et al.*, 2009; Amaral *et al.*, 2012a; Perrin *et al.*, 2013). A dificuldade de resolver as relações evolutivas do clado é principalmente atribuída aos aspectos históricos de Delphininae. É consenso que a radiação de Delphininae foi um evento rápido e recente iniciado no Plioceno, no qual a divergência das espécies ocorreu ao longo do Pleistoceno (Kingston *et al.*, 2009; McGowen *et al.*, 2009; Steeman *et al.*, 2009; Amaral *et al.*, 2012a). Desta forma, linhagens sob rápida radiações representam um desafio para a sistemática porque poucos caracteres morfológicos são consistentes para produzir uma hipótese filogenética robusta e, possivelmente, a retenção de polimorfismos ancestrais e hibridização podem obscurecer as relações filogenéticas entre as linhagens (Amaral *et al.*, 2012b; Perrin *et al.*, 2013; Amaral *et al.*, 2014).

Nos primeiros trabalhos morfológicos realizados com golfinhos (tabela 1), *Steno*, *Sotalia* e *Sousa* foram agrupados baseados na morfologia do crânio, no qual *Sotalia* e *Sousa* compartilhavam mais similaridades do que com *Steno* (Flower 1883, Caballero *et al.*, 2008). True (1889) agrupou *Sotalia*, *Steno*, *Tursiops*, *Delphinus*, *Prodelphinus*, *Tursio*, *Lagenorhynchus*, *Sagmatias*, *Feresa*, *Cephalorhynchus*, *Neomeris*, *Phocoena*, *Grampus*, *Globicephalus* e *Pseudorca* em Delphininae. Estudos baseados na evolução dos sacos de ar acessórios e dos ouvidos sugeriram a inclusão dos gêneros *Tursiops*, *Stenella*, *Delphinus*, *Lagenorhynchus*, *Grampus* e *Lagenodelphis* em Delphininae (Fraser & Purves, 1960). Neste mesmo estudo, *Sousa* e *Steno* foram incluídos em Steninae devido à combinação de características primitivas e altamente especializadas (Fraser & Purves, 1960). Na análise da

morfologia dos ossos tímpano-periótico, Kasuya (1973) sugeriu que os gêneros *Sotalia*, *Sousa* e *Cephalorhynchus* devessem ser agrupados em Sotallinae e que *Tursiops*, *Stenella*, *Lissodelphis*, *Delphinus*, *Lagenorhynchus* e *Steno* deveriam ser agrupados em Delphininae. No estudo conduzido por Mead (1975), baseado na anatomia das passagens nasais externas e do complexo facial, *Delphinus*, *Stenella*, *Grampus*, *Tursiops*, *Lagenorhynchus*, *Lagenodelphis* e *Peponocephala* foram agrupados em Delphininae e foi sugerido que *Steno* e *Sousa* deveriam ser agrupados em Steninae.

Tabela 1. Resumo de estudos morfológicos de Delphinidae.

	Autor/Estudo	Inclusão dos gêneros em subfamílias		
		Delphininae	Steninae	Sotallinae
MORFOLOGIA	Flower (1883) - similaridades na morfologia do crânio		<i>Steno, Sotalia, Sousa</i>	
	True (1889)	<i>Sotalia, Steno, Tursiops, Delphinus, Prodelphinus, Tursio, Lagenorhynchus, Sagmatias, Feresa, Cephalorhynchus, Neomeris, Phocoena, Grampus, Globicephalis, Pseudorca</i>		
	Fraser & Purves (1960) - evolução dos sacos aéreos e ouvido	<i>Tursiops, Stenella, Delphinus, Lagenorhynchus, Grampus, Lagenodelphis</i>	<i>Sousa, Steno</i>	
	Kasuya (1973) - ossos tímpano-periótico	<i>Tursiops, Stenella, Lissodelphis, Delphinus, Lagenorhynchus, Steno</i>		<i>Sotalia, Sousa, Cephalorhynchus</i>
	Mead (1975) - anatomia das passagens nasais externas e do complexo facial	<i>Delphinus, Stenella, Grampus, Tursiops, Lagenorhynchus, Lagenodelphis, Peponocephala</i>	<i>Sousa, Steno</i>	
	Muizon (1988) - análise filogenética de Delphinida	<i>Delphinus, Stenella, Tursiops, Grampus, Lissodelphis, Lagenodelphis, Lagenorhynchus, Steno, Sotalia, Sousa</i>		
	Moreno (2008) - 1ª análise cladística de Delphinidae	<i>Delphinus, Tursiops, Stenella, Lagenodelphis, Leucopleurus,</i>	<i>Steno, Sotalia, Sousa</i>	

Estes estudos foram baseados apenas em similaridades e não incluíam qualquer sinapomorfia para os grupos (Caballero *et al.*, 2008). Muizon (1988) conduziu uma análise

das relações de Delphinida, que embora não tenha sido realizada através de análises computacionais, incluiu em Delphininae os gêneros *Delphinus*, *Stenella*, *Tursiops*, *Grampus*, *Lissodelphis*, *Lagenodelphis*, *Lagenorhynchus*, *Steno*, *Sotalia* e *Sousa*. A primeira análise cladística morfológica de Delphinidae foi realizada por I. B. Moreno (Universidade Federal do Rio Grande do Sul), incluindo dados de coloração e morfologias craniana e externa. Neste estudo, Delphininae foi recuperada com duas sinapomorfias exclusivas incluindo os gêneros *Delphinus*, *Tursiops*, *Stenella*, *Lagenodelphis* e *Leucopleurus* (= *Lagenorhynchus*) *acutus*. O gênero *Stenella* foi recuperado como não-monofilético, enquanto *Delphinus* e *Tursiops* foram monofiléticos. Além disso, a subfamília Steninae incluindo os gêneros *Steno*, *Sotalia* e *Sousa*, na qual *Sousa* e *Sotalia* são grupos irmãos, foi bem suportada com quatro sinapomorfias não-exclusivas.

O primeiro estudo baseado em dados moleculares de Delphinidae, foi realizado por Leduc *et al.*, (1999) através da análise cladística de dados mitocondriais do citocromo b. Neste estudo, os gêneros *Delphinus*, *Tursiops*, *Stenella*, *Lagenodelphis* e *Sousa* foram agrupados no clado Delphininae, enquanto que *Sotalia* e *Steno* foram agrupados em Stenoninae. Muitos estudos subsequentes ao de Leduc *et al.*, (1999) baseados em dados moleculares foram realizados para alguns dos táxons pertencentes à Delphinidae e sugerem também a inclusão de *Sousa* em Delphininae e diferem nas relações propostas entre as espécies (Kingston *et al.*, 2009; McGowen *et al.*, 2009; Steeman *et al.*, 2009; McGowen, 2011; Amaral *et al.*, 2012a; Perrin *et al.*, 2013). O estudo de Caballero *et al.*, (2008) quanto ao posicionamento de *Sotalia* em Delphinidae através de dados mitocondriais, íntrons autossômicos e do cromossomo Y, revelou que nas análises de dados combinados ou independentes *Sotalia* e *Sousa* devem ser incluídos em Delphininae, com a exclusão de *Steno*. Além disso, *Sousa* e *Sotalia* foram recuperados como táxons irmãos de acordo com as análises de DNA nuclear, mas esta relação não foi recuperada nas análises independentes de

DNA mitocondrial e combinadas de DNA nuclear e mitocondrial (Caballero *et al.*, 2008). Porém, análises do genoma mitocondrial completo revelam que *Steno bredanensis* é filogeneticamente mais relacionado a *Sotalia* (Cunha *et al.*, 2011).

Desde o pioneiro trabalho de Leduc *et al.*, (1999), é consenso que *Stenella* é um gênero não-monofilético, no qual algumas espécies são mais relacionadas com outros gêneros (Kingston *et al.*, 2009; McGowen *et al.*, 2009; Amaral *et al.*, 2012a; Perrin *et al.*, 2013). Análises de sequências de citocromo b recuperam com alto suporte um clado em Delphininae que inclui *Stenella clymene*, *Stenella coeruleoalba*, *Delphinus delphis*, *Delphinus capensis*, *Stenella frontalis*, *Tursiops aduncus* (nó “D” da Figura 1 de Leduc *et al.*, 1999). Neste estudo, *Stenella clymene* e *Stenella coeruleoalba* são táxons irmãos e o autor também sugere que *Tursiops aduncus* e *Stenella frontalis* representam espécies irmãs dada as similaridades morfológicas observadas por Perrin *et al.*, (1987). Além disso, *Tursiops truncatus* foi recuperado com táxon irmão do clado definido pelo nó “D”. Outras reconstruções filogenéticas moleculares suportam uma relação de espécies irmãs entre *Stenella clymene* e *Stenella coeruleoalba* em um clado com *Delphinus spp.*, *Stenella frontalis* e *Tursiops aduncus* (May-Collado & Agnarsson, 2006; Agnarsson & May-Collado, 2008; McGowen *et al.*, 2009; McGowen, 2011; Perrin *et al.*, 2013). Porém, todas estas reconstruções incluem apenas dados de citocromo b de *Stenella clymene*. A filogenia proposta por Steeman *et al.*, (2009) sugere um clado incluindo *Delphinus spp.*, *Stenella clymene*, *Stenella frontalis* e *Stenella coeruleoalba*, onde estas 2 últimas são reconstruídas como táxons irmãos. Embora Amaral *et al.*, (2012a) não incluíssem *Stenella clymene* em sua análise, o estudo reconstrói *Stenella frontalis* e *Stenella attenuata* como táxons-irmãos, em um clado junto com *Tursiops spp.*



Figura 2 Topologias para o clado Delphininae. Em: a) filogenia proposta por Leduc *et al.*, (1999), b) filogenia proposta por Amaral *et al.*, (2012a).

Perrin *et al.*, (1987) observou que *Stenella frontalis* é intermediária entre *Stenella attenuata* e *Tursiops truncatus* quanto ao tamanho e formato externo e sugere que estas três espécies compartilham uma série de características cranianas que os separam dos demais delfínídeos. Externamente, *Stenella frontalis* difere de *Stenella attenuata* por apresentar *spinal blaze* e por ter o ventre branco e, é muito semelhante ao padrão de coloração de *Tursiops truncatus* diferindo apenas na possessão de pintas dorsais, que por sua vez estão presentes em *Tursiops aduncus* (Perrin *et al.*, 1987). No estudo de redescrição de *Stenella clymene*, Perrin *et al.*, (1981) observou que esta espécie executa saltos semelhantes e é externamente similar a *Stenella longirostris*, enquanto que cranialmente *Stenella clymene* é semelhante a *Stenella coeruleoalba*. Morfologicamente, o crânio de *Stenella clymene* compartilha uma série de características com os golfinhos pelágicos *Delphinus delphis*, *Stenella coeruleoalba*, *Stenella longirostris* e *Lagenodelphis hosei*. E, não se assemelha com *Stenella attenuata*, *Stenella frontalis* e *Tursiops truncatus* (Perrin *et al.*, 1981; Perrin *et al.*, 1987).

Na análise filogenética proposta por I. B. Moreno (Universidade Federal do Rio Grande do Sul) baseada na morfologia, *Tursiops* foi recuperado como um táxon monofilético, no qual *Tursiops aduncus* e *Tursiops gephyreus* foram recuperados como táxons irmãos em relação à *Tursiops truncatus*. Além disso, foi observado que *Tursiops* e *Stenella frontalis* compartilham uma série de características que indicam uma relação de grupos irmão. O clado que une *Stenella attenuata* e *Stenella attenuata graffmani* foi recuperado como grupo irmão de todos os demais Delphininae. Assim diferente de Perrin *et al.*, (1981, 1987), I. B. Moreno (Universidade Federal do Rio Grande do Sul) sugere que *Tursiops aduncus*, *Tursiops truncatus* e *Stenella frontalis* compartilham uma série de características que os diferenciam das demais espécies de Delphininae.

Na análise molecular conduzida por McGowen *et al.*, (2009) para o clado Cetacea através de uma supermatriz, *Steno* foi recuperado como pertencente a subfamília Steninae; *Sotalia* foi recuperado como grupo irmão de Delphininae e *Leucopleurus* (= *Lagenorhynchus*) *acutus* representa uma linhagem que divergiu precocemente no clado Delphinidae; *Sousa* foi recuperado como a linhagem mais basal de Delphininae. Além disso, muitas outras relações dentro de Delphininae não foram bem resolvidas. Mais uma vez, *Stenella* foi recuperado como não-monofilético. Em um mesmo clado, *Stenella attenuata*, *Stenella longirostris* e *Lagenodelphis hosei* foram agrupados. Pela primeira vez em uma filogenia molecular, *Tursiops aduncus* foi recuperado como grupo irmão de *Tursiops truncatus*, sugerindo a monofilia de *Tursiops*. *Stenella clymene* e *Stenella coeruleoalba* foram recuperadas como espécies irmãs em relação à *Tursiops*.

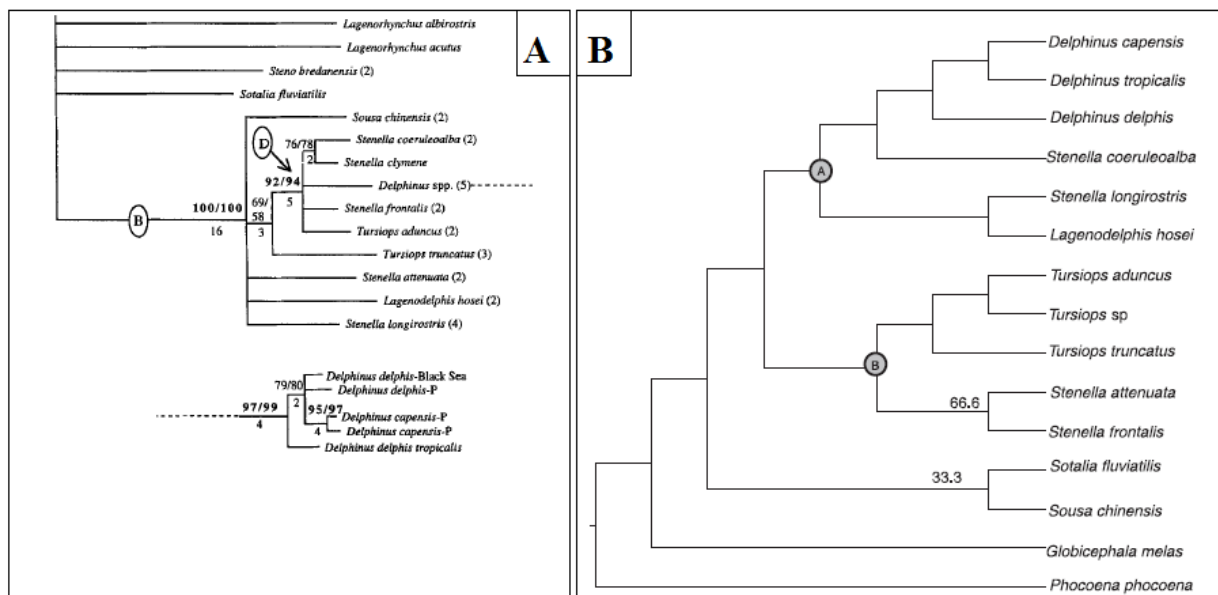
Na tentativa de resolver as relações filogenéticas de Delphininae através de uma amostragem completa dos táxons e incorporação de múltiplos indivíduos por espécie, Kingston *et al.*, (2009) construíram uma análise filogenética empregando sequências da região controladora do DNA mitocondrial e múltiplos polimorfismos (*Amplified fragment*

length polymorphism – AFLP). A filogenia multi-locus recuperou a relação de táxons irmãos entre *Stenella attenuata* e *Stenella frontalis*, embora essa relação não tenha sido recuperada através da análise de dados mitocondriais (Leduc *et al.*, 1999; Kingston *et al.*, 2009). Além disso, *Stenella clymene* e *Stenella longirostris* foram agrupadas como espécies irmãs, em relação ao clado contendo as espécies do gênero *Delphinus* (Figura 3A, Kingston *et al.*, 2009).

Amaral *et al.* (2012a) conduziram outra análise filogenética para resolver a topologia de Delphininae através de múltiplos genes e diferentes métodos, na qual *Tursiops* foi recuperado como um grupo monofilético irmão de *Stenella frontalis* e *Stenella attenuata* (Clado “B” da Figura 3, Amaral *et al.*, 2012a). Amaral *et al.*, (2014) realizaram um estudo para investigar a possível hibridação entre *Stenella coeruleoalba* e *Stenella longirostris* que teria resultado na origem de *Stenella clymene*, como sugerido por Perrin *et al.*, (1981). Embora, *Stenella clymene* já tenha se diferenciado das suas possíveis espécies parentais, o genoma mitocondrial de *Stenella clymene* é mais proximamente relacionado ao de *Stenella coeruleoalba*, enquanto que o genoma nuclear parece ser mais relacionado ao de *Stenella longirostris*. Adicionalmente, uma nova hipótese filogenética foi construída através de dados de DNA nuclear e resultou em um clado monofilético de *Tursiops* com *Stenella coeruleoalba*, *Stenella frontalis* foi recuperada como espécie irmã de *Stenella attenuata* e *Stenella clymene* parece ser filogeneticamente mais próxima de *Stenella longirostris*, *Lagenodelphis hosei* e *Delphinus*.

Perrin *et al.*, (2013) revisaram um total de 28 reconstruções filogenéticas baseadas em dados moleculares subsequentes ao estudo realizado por de Leduc *et al.*, (1999) e observou que nenhum dos estudos contemplou todos os possíveis táxons pertencentes a Delphininae. Foram analisadas mais profundamente 13 hipóteses que incluíam ao menos 10 espécies. Os autores sugerem que devido à incongruência entre as relações filogenéticas já propostas para

o grupo, todas as espécies de Delphininae devem ser sinonimizadas ao gênero *Delphinus*, sob a justificativa de que a atual taxonomia não reflete a real história evolutiva do grupo (Perrin *et al.*, 2013). Todos os autores que propuseram a sinonimização de algum táxon dentro da história taxonômica de Delphininae (Hershkovitz, 1966), acabaram causando mais confusão à taxonomia do grupo.

Distribuição das espécies do clado Delphininae

Em um dos mais utilizados guias de mamíferos marinhos do mundo, o padrão de distribuição de 72 espécies de Odontoceti foram descritos e 17 espécies foram consideradas de ampla distribuição (Jefferson *et al.*, 2008). Das espécies descritas com ampla distribuição, 70% (12 espécies) pertencem à família Delphinidae, sendo que aproximadamente 42% (5 espécies) estão agrupadas no clado Delphininae. Espécies cujo padrão de distribuição é considerado amplo, em muitos casos reflete a falta de conhecimento sobre a real distribuição de algumas espécies de odontocetos, principalmente no que se refere às espécies oceânicas. Apesar da alta capacidade de dispersão e aparente continuidade do ambiente marinho, as espécies de cetáceos exibem estruturação populacional restrita a uma fina-escala do ambiente (Quérouil *et al.*, 2010). Muitos estudos propõem a existência de ecótipos para as espécies que apresentam ampla distribuição, estes ecótipos parecem estar principalmente relacionados a diferenças entre populações restritas a ambientes costeiros ou populações estruturadas dentro de uma pequena área geográfica (Natoli *et al.*, 2004; Escorza-Trevino *et al.*, 2005; Adams & Rosel, 2006; Natoli *et al.*, 2006; Morin *et al.*, 2010; Charlton-Robb *et al.*, 2011; Amaral *et al.*, 2012b; Andrews *et al.*, 2013; Mendez *et al.*, 2013; Moura *et al.*, 2013). No geral, esses estudos mostram a especialização das espécies a nichos locais, ou em outras palavras, o ambiente marinho é capaz de suportar a distribuição de uma espécie sobre uma ampla área geográfica, no entanto variações locais no hábitat podem levar a especialização a nichos locais (Hoelzel, 1998).

O Gênero *Delphinus* Linnaeus, 1758

Existem duas espécies que pertencem ao gênero *Delphinus*: *D. capensis* Gray, 1828 (golfinho-comum-de-bico-longo) e *D. delphis* Linnaeus, 1758 (golfinho-comum-de-bico-curto).

Conforme informações da IUCN, quanto a *D. capensis* alguns pesquisadores sugerem a existência de 2 subespécies, *D. capensis capensis* e *D. capensis tropicalis*. A subespécie *D. capensis capensis* ocorre nos oceanos Atlântico e Pacífico em subpopulações disjuntas ao longo da costa leste da América do Sul, leste e sul da África, sul do Japão, Coreia e norte de Taiwan, além do Califórnia central até o sul do México e Peru. Enquanto que a subespécie *D. capensis tropicalis* ocorre no Indo-Pacífico, ao leste do mar Vermelho ao sul da China e Indonésia (Hammond *et al.*, 2012a).



Figura 3 Mapa da distribuição global de *Delphinus capensis* (Adaptado de Hammond *et al.*, 2012a).

A espécie *D. delphis* tem hábitos oceânicos e distribui-se amplamente em águas tropicais a temperadas dos oceanos Atlântico e Pacífico (Hammond *et al.*, 2012b). A subespécie *D. delphis ponticus*, o golfinho comum do mar Negro (Amaral *et al.*, 2012b).

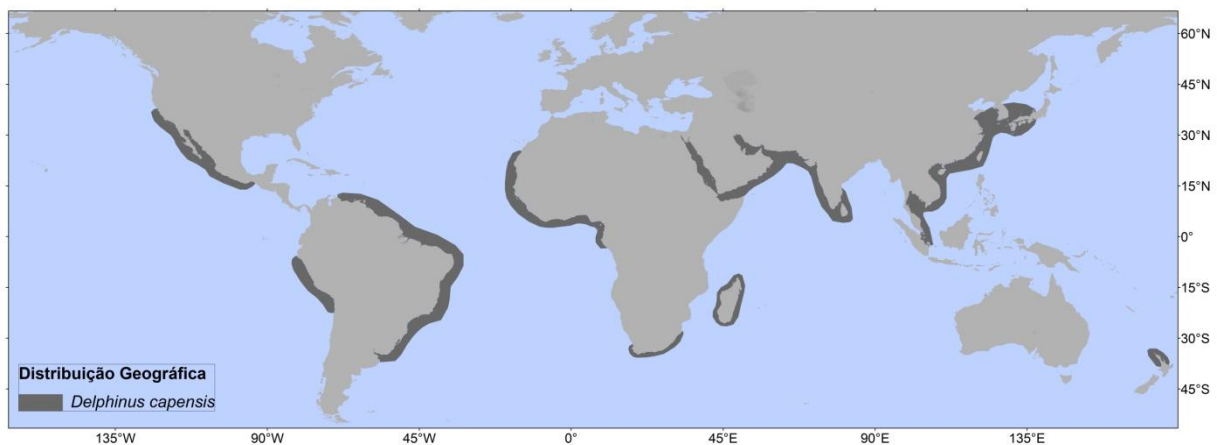

Figura 4 Mapa da distribuição global de *Delphinus delphis* (Adaptado de Hammond *et al.*, 2012b).

O Gênero *Lagenodelphis* Fraser, 1956

O gênero apresenta somente uma espécie *Lagenodelphis hosei* Fraser, 1956. Pouco se sabe a respeito desta espécie e, de acordo com a IUCN, este golfinho tem uma distribuição pantropical entre 30°N e 30°S nos oceanos Atlântico, Pacífico e Índico (Hammond *et al.*, 2012c).

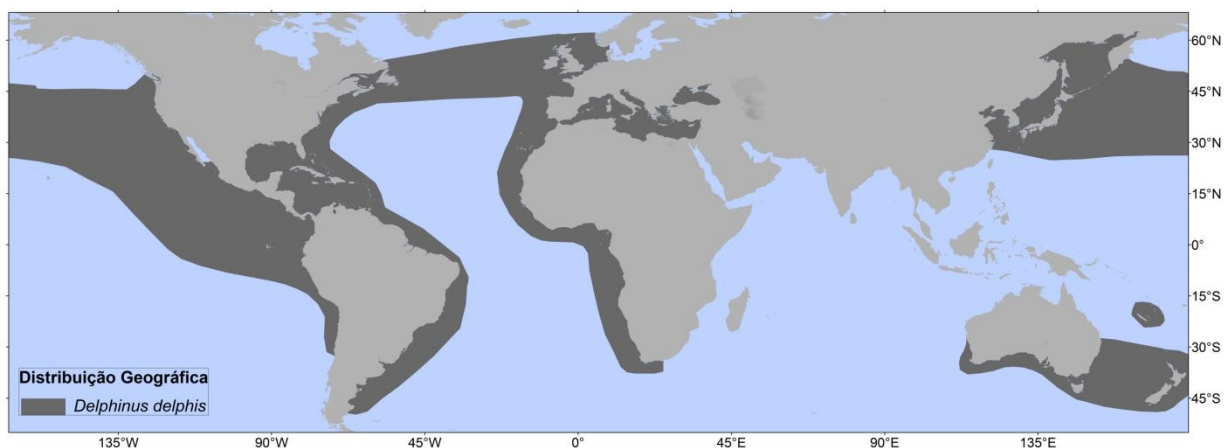

Figura 5 Mapa da distribuição global de *Lagenodelphis hosei* (Adaptado de Hammond *et al.*, 2012c).

O Gênero *Stenella* Gray, 1866

O gênero é um dos mais representativos da família Delphinidae, pois, atualmente, inclui cinco espécies: *S. attenuata* (Gray, 1846) (golfinho-pintado-pantropical), *S. clymene* (Gray, 1850) (golfinho-de-Clymene), *S. coeruleoalba* (Meyen, 1833) (golfinho-listrado), *S.*

frontalis (Cuvier, 1829) (golfinho-pintado-do-Atlântico) e *S. longirostris* (Gray, 1828) (golfinho-rotador). Estes golfinhos distribuem-se amplamente em oceanos tropicais, subtropicais e temperados (Moreno *et al.*, 2005)

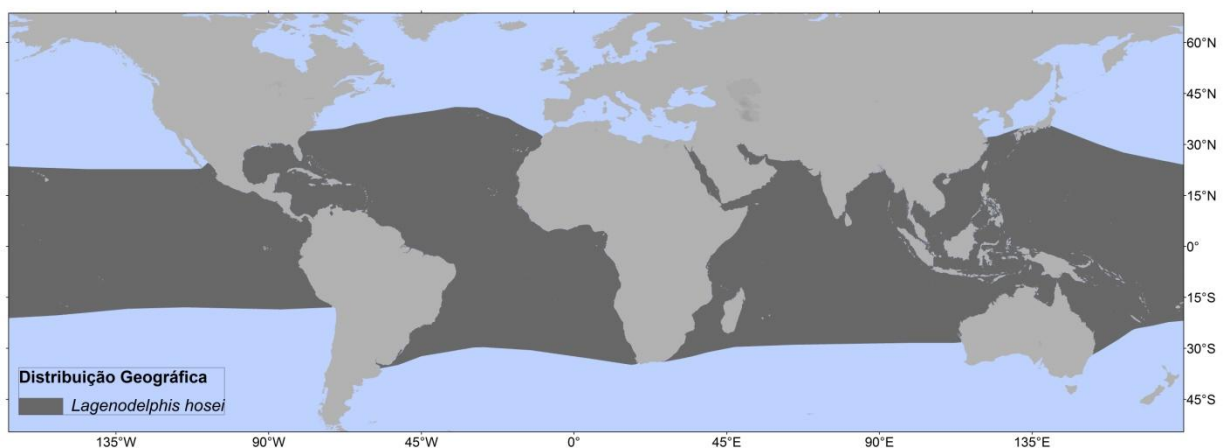
Os golfinhos-pintados-pantropicais (*S. attenuata*) são encontrados em abundância nas porções de baixa latitude dos Oceanos Atlântico, Índico e Pacífico, porém sua distribuição está limitada a faixa entre 40°N e 40°S (Perrin, 2001). Pelo menos uma subespécie é reconhecida, *S. attenuata graffmani* (Lönnberg, 1934) restrita ao Pacífico Tropical Leste (Perrin, 1975).



Figura 6 Mapa da distribuição global de *Stenella attenuata* (Adaptado de Hammond *et al.*, 2012d).

O golfinho-de-clymene (*S. clymene*) é uma espécie endêmica do Oceano Atlântico, sendo encontrada em águas tropicais e subtropicais (Fertl *et al.*, 2003).

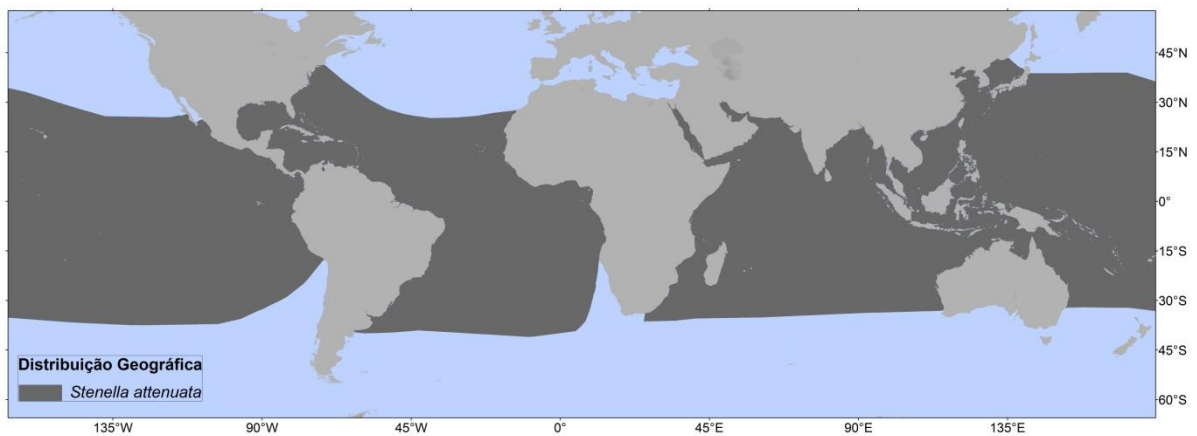

Figura 7 Mapa da distribuição global de *Stenella clymene* (Adaptado Hammond *et al.*, 2012e).

Os golfinhos listrados (*S. coeruleoalba*) estão amplamente distribuídos, sendo encontrados nos Oceanos Atlântico, Índico e Pacífico, tanto em águas quentes como temperadas. Diferentemente das demais *Stenella*, o golfinho listrado tem seus limites de distribuição expandidos até latitudes mais altas (40° S e 50° N), tolera amplas variações na temperatura da superfície do mar e, muitas vezes, sua ocorrência está associada a zonas de ressurgência (Perrin *et al.*, 1994).

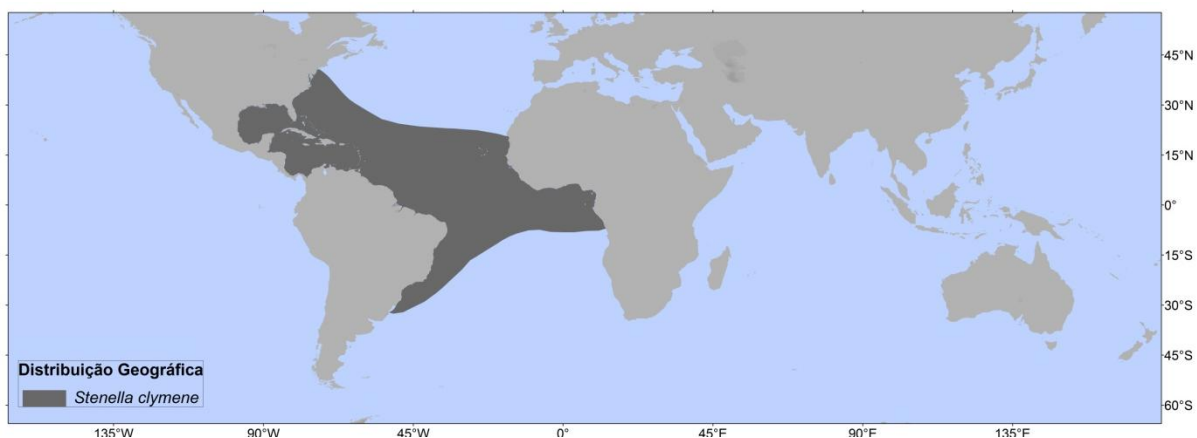

Figura 8 Mapa da distribuição global de *Stenella coeruleoalba* (Adaptado de Hammond *et al.* 2012f).

O golfinho-pintado-do-Atlântico (*S. frontalis*) é endêmico do Oceano Atlântico e, diferentemente das demais espécies do gênero tem sua distribuição restrita a águas relativamente rasas. Além disso, é altamente variável geograficamente, levando a confusões taxonômicas e má identificação dos espécimes (Perrin *et al.*, 1994; Perrin, 2002b). Moreno *et al.*, (2005) observaram que os registros de *S. frontalis* no Oceano Atlântico Sul Ocidental ocorrem ao norte de 6°S e entre 21 e 33°S, sugerindo uma grande área no Nordeste do Brasil, entre 6 e 21°S, sem a ocorrência da espécie, sugerindo a existência de duas populações distintas e isoladas uma da outra.

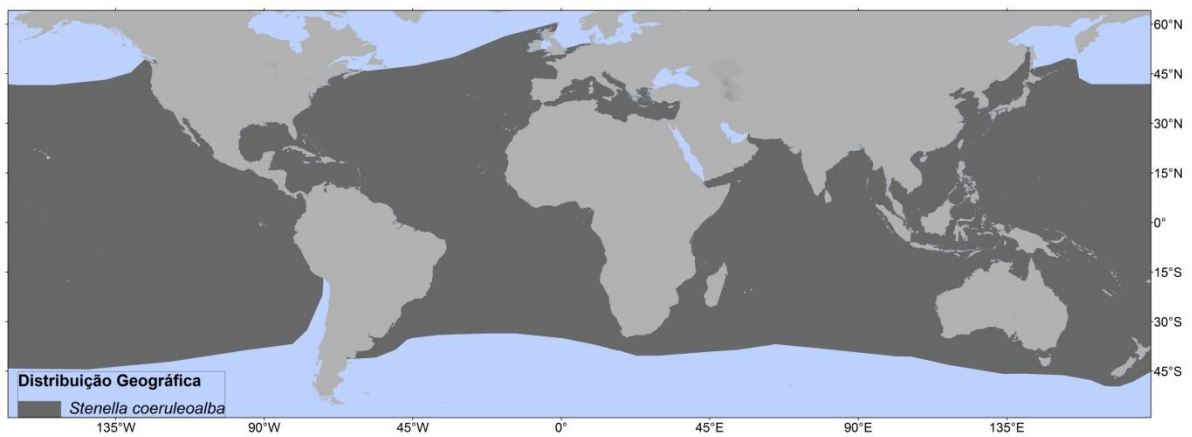

Figura 9 Mapa da distribuição global de *Stenella frontalis* (Adaptado de Hammond *et al.* 2012g).

O golfinho-rotator (*S. longirostris*) é encontrado em águas tropicais e subtropicais, estando limitado à faixa entre 30 - 40° N e 20 - 30° S (Jefferson *et al.*, 1993; Perrin, 2002c). Pode ser encontrado em águas profundas, mas sua distribuição está frequentemente associada às águas rasas presentes em ilhas oceânicas, bancos de areia e enseadas (Perrin, 2002c). São descritas três subespécies *Stenella longirostris longirostris*, *Stenella longirostris roseiventris* e *Stenella longirostris centroamericana* (Perrin, 1990).

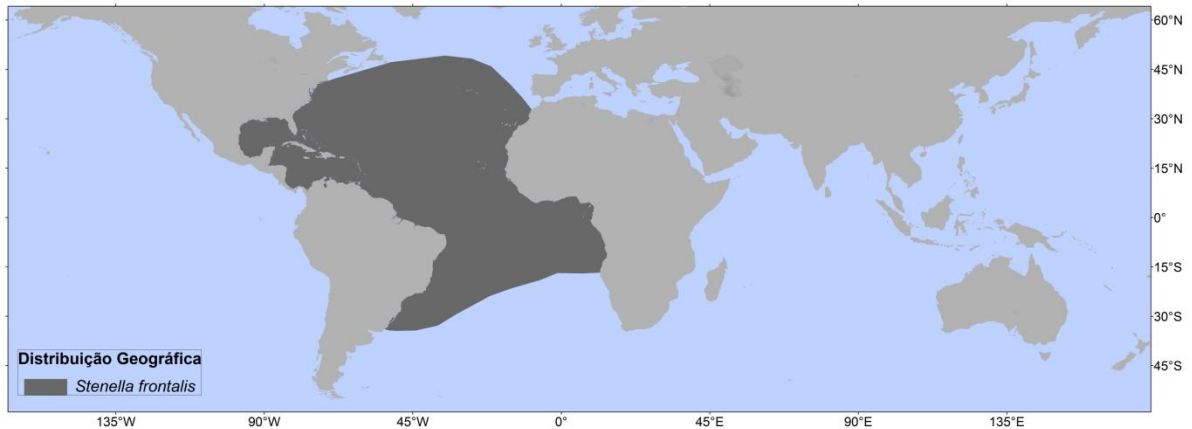

Figura 10 Mapa da distribuição global de *Stenella longirostris* (Adaptado de Hammond *et al.* 2012h).

O Gênero *Tursiops* Gervais, 1855

Atualmente, o gênero apresenta três espécies: *T. aduncus* (Ehrenberg, 1833) (golfinho-nariz-de-garrafa do Indo-Pacífico), a espécie recentemente descrita *T. australis* Charlton-Robb, Gershwin, Thompson, Austin, Owen & McKechnie, 2011 (Charlton-Robb *et*

al., 2011) e *Tursiops truncatus* (Montagu,1821) (golfinho-nariz-de-garrafa comum) . Mas a taxonomia do gênero é bastante confusa, devido à variação geográfica e é possível que novas espécies sejam acrescentadas no gênero. Quanto à distribuição geográfica, de acordo com os dados da IUCN, *T. aduncus* tem uma distribuição descontínua nas águas temperadas a tropicais do Indo-Pacífico (Hammond *et al.*, 2012i). Já *T. australis* é endêmica de uma pequena região do sul e sudeste da Austrália (Charlton-Robb *et al.*, 2011).

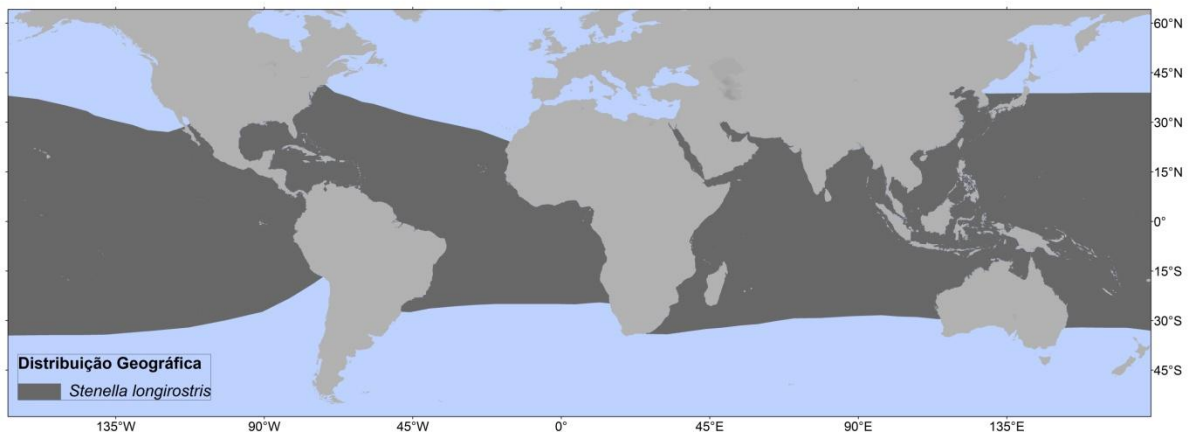

Figura 11 Mapa da distribuição global de *Tursiops aduncus* (Adaptado de Hammond *et al.*, 2012i).

E, *T. truncatus* está amplamente distribuída em águas tropicais e temperadas.

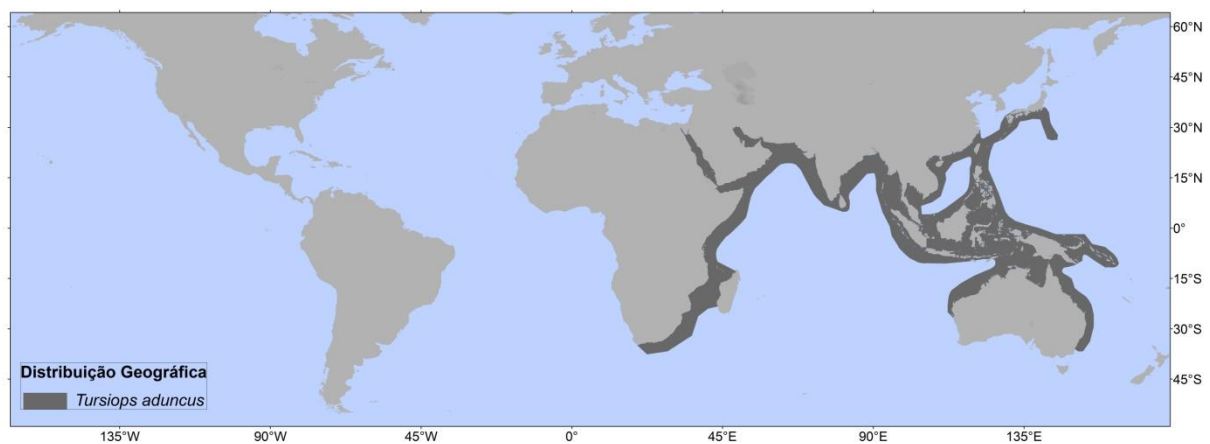

Figura 12 Mapa da distribuição global de *Tursiops truncatus* (Adaptado de Hammond *et al.*, 2012j).

Análise Espacial de Vicariância

Este estudo visa compreender os processos envolvidos na evolução de Delphininae à luz da biogeografia histórica, através do método da “*Spatial Analysis of Vicariance*” (Arias *et*

al., 2011). Este método que busca esclarecer a história do táxon foi baseado nas ideias de Hovemkamp (1997) que propõe a identificação de possíveis eventos vicariantes, os quais correspondem à barreiras que impedem ou dificultam a dispersão das espécies (Hovenkamp, 1997, 2001; Arias *et al.*, 2011). Hovenkamp (1997) sugere que as informações necessárias para a reconstrução de eventos vicariantes estão presentes em uma análise cladística. Em suma, a principal meta da análise espacial de vicariância é identificar taxóons-irmãos com distribuições disjuntas (Arias *et al.*, 2011). A análise espacial de vicariância está implementada no programa *Spatial “Vicariance Inference Program”* (VIP) (Arias, 2010). A metodologia requer uma hipótese filogenética e dados de distribuição dos terminais. A análise biogeográfica foi conduzida a partir de de duas hipóteses filogenéticas, sendo uma construída a partir de dados moleculares e outra de dados morfológicos, e que incluem os terminais do clado Delphininae e Steninae. A partir de revisão exaustiva da literatura, registros de ocorrência das unidades taxonômicas presentes nas hipóteses filogenéticas foram compilados. A busca por distribuições disjuntas entre grupos filogeneticamente relacionados foi conduzida através de 1.000 iterações. A grade de células utilizada foi 2°x2° com preenchimento máximo ajustado para 1. O custo atribuído para a remoção total da distribuição do terminal foi 1 e o custo de uma remoção parcial foi ajustado para 0,75. Não foi utilizado percentual de sobreposição. Em ambas análises de vicariância realizadas tanto com dados moleculares quanto morfológicos, foram recuperados eventos vicariantes e diferentes cenários biogeográficos foram hipotetizados. A separação entre Delphininae e Steninae parece estar relacionada ao soerguimento do Istmo do Panamá que ocorreu há 7 – 3,5 Ma (Montes *et al.*, 2012) e teve grande importância na fragmentação da biota marinha entre os oceanos Pacífico e o Atlântico (Briggs, 2003; Lessions, 2008). As disjunções encontradas em táxons terminais estão principalmente relacionadas à Corrente de Benguela e, também a Barreira do Pacífico Oriental (Lessios & Robertson, 2006; Floeter *et al.*, 2008;

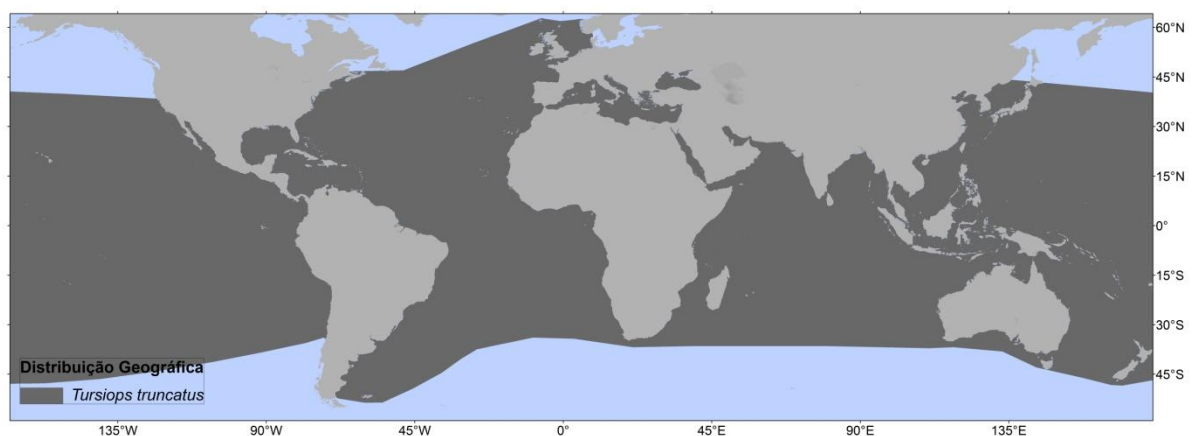
Lessions, 2008). A corrente de Benguela é um importante sistema de ressurgência dos oceanos, sendo um dos mais produtivos ecossistemas do mundo (Andrews & Hutchings, 1980; Cohen *et al.*, 1992; Spalding *et al.*, 2012), cuja oscilação da temperatura, a partir de 3 Ma atrás (Marlow *et al.*, 2000), promoveu a fragmentação da fauna marinha tropical durante períodos frios, mas permitiu o intercâmbio de faunas entre o Atlântico e o Índico durante períodos mais quentes. Os demais eventos vicariantes encontrados parecem estar relacionados à fragmentação do ambiente costeiro no Atlântico e Indo-Pacífico durante os períodos glaciais e interglaciais do Pleistoceno (Caballero *et al.*, 2007; Mendez *et al.*, 2013).

REFERÊNCIAS

- Adams, L. & Rosel, P. (2006) Population differentiation of the Atlantic spotted dolphin (*Stenella frontalis*) in the western North Atlantic, including the Gulf of Mexico. *Marine Biology*, 148, 671-681.
- Agnarsson, I. & May-Collado, L.J. (2008) The phylogeny of Cetartiodactyla: The importance of dense taxon sampling, missing data, and the remarkable promise of cytochrome b to provide reliable species-level phylogenies. *Molecular Phylogenetics and Evolution*, 48, 964-985.
- Amaral, A.R., Jackson, J.A., Möller, L.M., Beheregaray, L.B. & Manuela Coelho, M. (2012a) Species tree of a recent radiation: The subfamily Delphininae (Cetacea, Mammalia). *Molecular Phylogenetics and Evolution*, 64, 243-253.
- Amaral, A.R., Lovewell, G., Coelho, M.M., Amato, G. & Rosenbaum, H.C. (2014) Hybrid Speciation in a Marine Mammal: The Clymene Dolphin (*Stenella clymene*). *PLoS ONE*, 9, e83645.
- Amaral, A.R., Beheregaray, L.B., Bilgmann, K., Freitas, L., Robertson, K.M., Sequeira, M., Stockin, K.A., Coelho, M. & Möller, L.M. (2012b) Influences of past climatic changes on historical population structure and demography of a cosmopolitan marine predator, the common dolphin (genus *Delphinus*). *Molecular Ecology*, 21, 4854-4871.
- Andrews, K.R., Perrin, W.F., Oremus, M., Karczmarski, L., Bowen, B.W., Puritz, J.B. & Toonen, R.J. (2013) The evolving male: spinner dolphin (*Stenella longirostris*) ecotypes are divergent at Y chromosome but not mtDNA or autosomal markers. *Molecular Ecology*, 22, 2408-2423.
- Andrews, W. & Hutchings, L. (1980) Upwelling in the southern Benguela Current. *Progress in Oceanography*, 9, 1-81.
- Arias, J.S. (2010) *Vicariance Inference Program - VIP*.
- Arias, J.S., Szumik, C.A. & Goloboff, P.A. (2011) Spatial analysis of vicariance: a method for using direct geographical information in historical biogeography. *Cladistics*, 27, 617-628.
- Barnes, L.G. (1990) The Fossil Record and Evolutionary Relationships of the Genus *Tursiops*. *The Bottlenose dolphin* (ed. by S. Leatherwood and R.R. Reeves), pp. 3-26. Academic Press, San Diego.
- Barnes, L.G. (2002) Cetacea, Overview. *Encyclopedia of Marine Mammals* (ed. by W.F. Perrin, B. Würsig and J.G.M. Thewissen), pp. 204-208. Academic Press, San Diego.

- Baumgartner, M.F., Mullin, K.D., May, L.N. & Leming, T.D. (2001) Cetacean habitats in the northern Gulf of Mexico. *Fishery Bulletin*, 99, 219-239.
- Bierne, N., Bonhomme, F. & David, P. (2003) Habitat preference and the marine-speciation paradox. *Proceedings: Biological Sciences*, 270, 1399-1409.
- Caballero, S., Jackson, J., Mignucci-Giannoni, A.A., Barrios-Garrido, H., Beltrán-Pedrerros, S., Montiel-Villalobos, M.a.G., Robertson, K.M. & Baker, C.S. (2008) Molecular systematics of South American dolphins *Sotalia*: Sister taxa determination and phylogenetic relationships, with insights into a multi-locus phylogeny of the Delphinidae. *Molecular Phylogenetics and Evolution*, 46, 252-268.
- Charlton-Robb, K., Gershwin, L.-a., Thompson, R., Austin, J., Owen, K. & McKechnie, S. (2011) A New Dolphin Species, the Burrunan Dolphin *Tursiops australis* sp. nov., Endemic to Southern Australian Coastal Waters. *PLoS ONE*, 6, e24047.
- Cohen, A.L., Parkington, J.E., Brundrit, G.B. & van der Merwe, N.J. (1992) A Holocene marine climate record in mollusc shells from the southwest African coast. *Quaternary Research*, 38, 379-385.
- Cunha, H.A., Moraes, L.C., Medeiros, B.V., Lailson-Brito, J., Jr., da Silva, V.M.F., Solé-Cava, A.M. & Schrago, C.G. (2011) Phylogenetic Status and Timescale for the Diversification of *Steno* and *Sotalia* Dolphins. *PLoS ONE*, 6, e28297.
- Escorza-Trevino, S., Archer, F.I., Rosales, M., Lang, A. & Dizon, A.E. (2005) Genetic differentiation and intraspecific structure of eastern tropical Pacific spotted dolphins, *Stenella attenuata*, revealed by DNA analyses. *Conservation Genetics*, 6, 587-600.
- Fedorov, A.V., Dekens, P.S., McCarthy, M., Ravelo, A.C., deMenocal, P.B., Barreiro, M., Pacanowski, R.C. & Philander, S.G. (2006) The Pliocene Paradox (Mechanisms for a Permanent El Niño). *Science*, 312, 1485-1489.
- Fertl, D., Jefferson, T.A., Moreno, I.B., Zerbini, A.N. & Mullin, K.D. (2003) Distribution of the Clymene dolphin *Stenella clymene*. *Mammal Review*, 33, 253-271.
- Floeter, S.R., Rocha, L.A., Robertson, D.R., Joyeux, J.C., Smith-Vaniz, W.F., Wirtz, P., Edwards, A.J., Barreiros, J.P., Ferreira, C.E.L., Gasparini, J.L., Brito, A., Falcón, J.M., Bowen, B.W. & Bernardi, G. (2008) Atlantic reef fish biogeography and evolution. *Journal of Biogeography*, 35, 22-47.
- Flower, W.H. (1883) On the characters and divisions of the family Delphinidae. *Proceedings Zoological Society of London*, 466-513.
- Forcada, J. (2002) Distribution. *Encyclopedia of Marine Mammals* (ed. by W.F. Perrin, B. Würsig and J.G.M. Thewissen), pp. 327-333. Academic Press, San Diego.
- Fordyce, R., Merrick, J., Archer, M., Hickey, G. & Lee, M. (2006) A southern perspective on cetacean evolution and zoogeography. *Evolution and Biogeography of Australasian Vertebrates. AusSciPub [Australian Scientific Publishing], Sydney*, 755-778.
- Fordyce, R.E. (2002a) Cetacean Evolution. *Encyclopedia of Marine Mammals* (ed. by W.F. Perrin, B. Würsig and J.G.M. Thewissen), pp. 214-220. Academic Press, San Diego.
- Fordyce, R.E. (2002b) Fossil Record. *Encyclopedia of Marine Mammals* (ed. by W.F. Perrin, B. Würsig and J.G.M. Thewissen), pp. 453-471. Academic Press, San Diego.
- Fordyce, R.E. (2003) Cetaceans Evolution and Eocene-Oligocene Oceans Revisited. *From greenhouse to icehouse: the marine Eocene-Oligocene transition* (ed. by D.R. Prothero, L.C. Ivany and E.A. Nesbitt), pp. 154-170. Columbia University Press, New York.
- Fordyce, R.E. & Muizon, C.d. (2001) Evolutionary history of cetaceans: a review. *Secondary Adaptation of Tetrapods to Life in Water: Proceedings of the international meeting, Poitiers, 1996* (ed. by J.M. Mazin and V.D. Buffrénil), pp. 169-233. Verlag Dr. Friedrich Pfeil, München.

- Fordyce, R.E., Quilty, P.G. & Daniels, J. (2002) *Australodelphis mirus*, a bizarre new toothless ziphiid-like fossil dolphin (Cetacea: Delphinidae) from the Pliocene of Vestfold Hills, East Antarctica. *Antarctic Science*, 14, 37-54.
- Fraser, F.C. & Purves, P.E. (1960) *Hearing in cetaceans: evolution of the accessory air sacs and the structure and function of the outer and middle ear in recent cetaceans*. British Museum (Natural History).
- Hammond, P., Bearzi, G., Bjørge, A., Forney, K., Karczmarski, L., Kasuya, T., Perrin, W., Scott, M., Wang, A., Wells, R. & Wilson, B. (2012a) *Delphinus capensis*. In: *IUCN 2012*. IUCN Red List of Threatened Species.
- Hammond, P., Bearzi, G., Bjørge, A., Forney, K., Karczmarski, L., Kasuya, T., Perrin, W., Scott, M., Wang, A., Wells, R. & Wilson, B. (2012b) *Delphinus delphis*. In: *IUCN 2012*. IUCN Red List of Threatened Species.
- Hammond, P., Bearzi, G., Bjørge, A., Forney, K., Karczmarski, L., Kasuya, T., Perrin, W., Scott, M., Wang, A., Wells, R. & Wilson, B. (2012c) *Lagenodelphis hosei*. In: *IUCN 2012*. IUCN Red List of Threatened Species.
- Hammond, P., Bearzi, G., Bjørge, A., Forney, K., Karczmarski, L., Kasuya, T., Perrin, W., Scott, M., Wang, A., Wells, R. & Wilson, B. (2012d) *Stenella attenuata*. In: *IUCN 2012*. IUCN Red List of Threatened Species.
- Hammond, P., Bearzi, G., Bjørge, A., Forney, K., Karczmarski, L., Kasuya, T., Perrin, W., Scott, M., Wang, A., Wells, R. & Wilson, B. (2012e) *Stenella clymene*. In: *IUCN 2012*. IUCN Red List of Threatened Species.
- Hammond, P., Bearzi, G., Bjørge, A., Forney, K., Karczmarski, L., Kasuya, T., Perrin, W., Scott, M., Wang, A., Wells, R. & Wilson, B. (2012f) *Stenella coeruleoalba*. In: *IUCN 2012*. IUCN Red List of Threatened Species.
- Hammond, P., Bearzi, G., Bjørge, A., Forney, K., Karczmarski, L., Kasuya, T., Perrin, W., Scott, M., Wang, A., Wells, R. & Wilson, B. (2012g) *Stenella frontalis*. In: *IUCN 2012*. IUCN Red List of Threatened Species.
- Hammond, P., Bearzi, G., Bjørge, A., Forney, K., Karczmarski, L., Kasuya, T., Perrin, W., Scott, M., Wang, A., Wells, R. & Wilson, B. (2012h) *Stenella longirostris*. In: *IUCN 2012*. IUCN Red List of Threatened Species.
- Hammond, P., Bearzi, G., Bjørge, A., Forney, K., Karczmarski, L., Kasuya, T., Perrin, W., Scott, M., Wang, A., Wells, R. & Wilson, B. (2012i) *Tursiops aduncus*. In: *IUCN 2012*. IUCN Red List of Threatened Species.
- Hammond, P., Bearzi, G., Bjørge, A., Forney, K., Karczmarski, L., Kasuya, T., Perrin, W., Scott, M., Wang, A., Wells, R. & Wilson, B. (2012j) *Tursiops truncatus*. In: *IUCN 2012*. IUCN Red List of Threatened Species.
- Hershkovitz, P. (1966) Catalog of living whales.
- Hoelzel, A. (1998) Genetic structure of cetacean populations in sympatry, parapatry, and mixed assemblages: implications for conservation policy. *Journal of Heredity*, 89, 451-458.
- Hovenkamp, P. (1997) Vicariance Events, not Areas, Should be Used in Biogeographical Analysis. *Cladistics*, 13, 67-79.
- Hovenkamp, P. (2001) A direct method for the analysis of vicariance patterns. *Cladistics*, 17, 260-265.
- Jefferson, T.A., Webber, M.A., Pitman, R. & (2008) *Marine mammals of the world: A comprehensive guide to their identification*. Academic Press, London.
- Kasuya, T. (1973) Systematic consideration of recent toothed whales based on the morphology of tympano-periotic bone. *Scientific Reports of the Whales Research Institute*, 25, 1-103.

- Kingston, S., Adams, L. & Rosel, P. (2009) Testing mitochondrial sequences and anonymous nuclear markers for phylogeny reconstruction in a rapidly radiating group: molecular systematics of the Delphininae (Cetacea: Odontoceti: Delphinidae). *BMC Evolutionary Biology*, 9, 245.
- Leduc, R.G. (2002) Delphinids, Overview. *Encyclopedia of Marine Mammals* (ed. by W.F. Perrin, B. Würsig and J.G.M. Thewissen), pp. 310-314. Academic Press, San Diego.
- Leduc, R.G., Perrin, W.F. & Dizon, A.E. (1999) Phylogenetic relationships among the delphinid cetaceans based on full cytochrome b sequences. *Marine Mammal Science*, 15, 619-648.
- Lessions, H.A. (2008) The great american schism: Divergence of marine organisms after the rise of Central American Isthmus. *Annual Review of Ecology, Evolution and Systematics*, 39, 63-91.
- Lessios, H.A. & Robertson, D.R. (2006) Crossing the impassable: genetic connections in 20 reef fishes across the eastern Pacific barrier. *Proceedings of the Royal Society B: Biological Sciences*, 273, 2201-2208.
- Marlow, J.R., Lange, C.B., Wefer, G. & Rosell-Melé, A. (2000) Upwelling Intensification As Part of the Pliocene-Pleistocene Climate Transition. *Science*, 290, 2288-2291.
- May-Collado, L. & Agnarsson, I. (2006) Cytochrome b and Bayesian inference of whale phylogeny. *Mol Phyl Evol*, 38, 344 - 354.
- McGowen, M.R. (2011) Toward the resolution of an explosive radiation—A multilocus phylogeny of oceanic dolphins (Delphinidae). *Molecular Phylogenetics and Evolution*, 60, 345-357.
- McGowen, M.R., Spaulding, M. & Gatesy, J. (2009) Divergence date estimation and a comprehensive molecular tree of extant cetaceans. *Molecular Phylogenetics and Evolution*, 53, 891-906.
- Mead, J.G. (1975) Anatomy of the external nasal passages and facial complex in the Delphinidae (Mammalia: Cetacea). *Smithsonian Contributions to Zoology*, 207, 1-35.
- Mendez, M., Jefferson, T.A., Kolokotronis, S.-O., Krützen, M., Parra, G.J., Collins, T., Minton, G., Baldwin, R., Berggren, P., Särnblad, A., Amir, O.A., Peddemors, V.M., Karczmarski, L., Guissamulo, A., Smith, B., Sutaria, D., Amato, G. & Rosenbaum, H.C. (2013) Integrating multiple lines of evidence to better understand the evolutionary divergence of humpback dolphins along their entire distribution range: a new dolphin species in Australian waters? *Molecular Ecology*, 22, 5936-5948.
- Montes, C., Cardona, A., McFadden, R., Morón, S.E., Silva, C.A., Restrepo-Moreno, S., Ramírez, D.A., Hoyos, N., Wilson, J., Farris, D., Bayona, G.A., Jaramillo, C.A., Valencia, V., Bryan, J. & Flores, J.A. (2012) Evidence for middle Eocene and younger land emergence in central Panama: Implications for Isthmus closure. *Geological Society of America Bulletin*, 124, 780-799.
- Moreno, I.B., Zerbini, A.N., Danilewicz, D., Santos, M.C.D., Simoes-Lopes, P.C., Lailson-Brito, J. & Azevedo, A.F. (2005) Distribution and habitat characteristics of dolphins of the genus *Stenella* (Cetacea : Delphinidae) in the southwest Atlantic Ocean. *Marine Ecology Progress Series*, 300, 229-240.
- Morin, P.A., Archer, F.I., Foote, A.D., Vilstrup, J., Allen, E.E., Wade, P., Durban, J., Parsons, K., Pitman, R., Li, L., Bouffard, P., Abel Nielsen, S.C., Rasmussen, M., Willerslev, E., Gilbert, M.T.P. & Harkins, T. (2010) Complete mitochondrial genome phylogeographic analysis of killer whales (*Orcinus orca*) indicates multiple species. *Genome Research*, 20, 908-916.
- Moura, A.E., Nielsen, S.C.A., Vilstrup, J., Moreno-Mayar, V., Gilbert, M.T.P., Gray, H.I., Natoli, A., Möller, L.M. & Hoelzel, A. (2013) Recent diversification of marine genus

- (*Tursiops* spp.) tracks habitat preference and environmental change. *Systematic Biology*, 0, -13.
- Muizon, C.d. (1988) Les relations phylogenetiques des Delphinida (Cetacea, mammalia). *Annales de Paléontologie* (ed by, pp. 159-227.
- Natoli, A., Peddemors, V.M. & Hoelzel, A.R. (2004) Population structure and speciation in the genus *Tursiops* based on microsatellite and mitochondrial DNA analyses. *Journal of Evolutionary Biology*, 17, 363-375.
- Natoli, A., Cañadas, A., Peddemors, V.M., Aguilar, A., Vaquero, C., Fernández-Piqueras, P. & Hoelzel, A.R. (2006) Phylogeography and alpha taxonomy of the common dolphin (*Delphinus* sp.). *Journal of Evolutionary Biology*, 19, 943-954.
- Pastene, L.A., Goto, M., Kanda, N., Zerbini, A.N., Kerem, D.A.N., Watanabe, K., Bessho, Y., Hasegawa, M., Nielsen, R., Larsen, F. & PalsbøLL, P.J. (2007) Radiation and speciation of pelagic organisms during periods of global warming: the case of the common minke whale, *Balaenoptera acutorostrata*. *Molecular Ecology*, 16, 1481-1495.
- Perrin, W. (1989) Dolphins, porpoises, and whales. *An action plan for the conservation of biological diversity: 1988-1992*, IUCN, Gland, Switzerland,
- Perrin, W. (1990) Subspecies of *Stenella longirostris* (Mammalia: Cetacea: Delphinidae). *Proceedings of the Biological Society of Washington*, 103, 453-463.
- Perrin, W. (2002a) Common dolphins *Delphinus delphis*, *D. capensis*, and *D. tropicalis*. *Encyclopedia of marine mammals*, 245-248.
- Perrin, W., Caldwell, D. & Caldwell, M. (1994) Atlantic Spotted Dolphin *Stenella frontalis* (G. Cuvier, 1829). *Handbook of marine mammals*, 5, 173 - 190.
- Perrin, W., Mitchell, E., Mead, J., Caldwell, D. & Van Bree, P. (1981) *Stenella clymene*, a rediscovered tropical dolphin of the Atlantic. *Journal of Mammalogy*, 583-598.
- Perrin, W.F. (1975) Variation os spotted and spinner porpoise (genus *Stenella*) in the Eastern Pacific and Hawaii. *Bulletin of the Scripps Institution of Oceanography of the University of California*, 21
- Perrin, W.F. (2001) *Stenella attenuata*. *Mammalian Species*, 1-8.
- Perrin, W.F. (2002b) Spinner dolphin *Stenella longirostris*. *Encyclopedia of Marine Mammals* (ed. by W.F. Perrin, B. Würsig and J.G.M. Thewissen), pp. 1174-1178. Academic Press, San Diego.
- Perrin, W.F. (2002c) Atlantic Spotted Dolphin - *Stenella frontalis*. *Encyclopedia of Marine Mammals* (ed. by W.F. Perrin, B. Wursig and J.G.M. Thewissen), pp. 47-49. Academic Press, San Diego.
- Perrin, W.F., Würsig, B. & Thewissen, J.G.M. (2009) *Encyclopedia of Marine Mammals*, 2 edn. Academic Press, San Diego.
- Perrin, W.F., Rosel, P.E. & Cipriano, F. (2013) How to contend with paraphyly in the taxonomy of the delphinine cetaceans? *Marine Mammal Science*, 29, 567-588.
- Perrin, W.F., Mitchell, E.D., Mead, J., Caldwell, D.K., Caldwell, M.C., van Bree, P.J.H. & Dawbin, W.H. (1987) Revision of the spotted dolphins, *Stenella* spp. *Marine Mammal Science*, 3, 99-170.
- Price, S.A., Bininda-Emonds, O.R.P. & Gittleman, J.L. (2005) A complete phylogeny of the whales, dolphins and even-toed hoofed mammals (Cetartiodactyla). *Biological Reviews*, 80, 445-473.
- Quérouil, S., Freitas, L., Cascão, I., Alves, F., Dinis, A., Almeida, J.R., Prieto, R., Borràs, S., Matos, J.A. & Mendonça, D. (2010) Molecular insight into the population structure of common and spotted dolphins inhabiting the pelagic waters of the Northeast Atlantic. *Marine Biology*, 157, 2567-2580.
- Soligo, C., Selley, R.C., Cocks, L.R.M. & Plimer, I.R. (2005) *The Pliocene*. Elsevier.

- Steeman, M.E., Hebsgaard, M.B., Fordyce, R.E., Ho, S.Y.W., Rabosky, D.L., Nielsen, R., Rahbek, C., Glenner, H., Sørensen, M.V. & Willerslev, E. (2009) Radiation of Extant Cetaceans Driven by Restructuring of the Oceans. *Systematic Biology*, 58, 573-585.
- Tezanos-Pinto, G., Baker, C.S., Russell, K., Martien, K., Baird, R.W., Hutt, A., Stone, G., Mignucci-Giannoni, A.A., Caballero, S., Endo, T., Lavery, S., Oremus, M., Olavarría, C. & Garrigue, C. (2009) A Worldwide Perspective on the Population Structure and Genetic Diversity of Bottlenose Dolphins (*Tursiops truncatus*) in New Zealand. *Journal of Heredity*, 100, 11-24.
- True, F.W. (1889) *Contributions to the natural history of the cetaceans: A review of the family Delphinidae*. US Government Printing Office.

Historical biogeography of Delphininae dolphins (Cetartiodactyla: Delphinidae)¹

Karina Bohrer do Amaral¹ & Ignacio Benites Moreno^{1,2}

¹Laboratório de Sistemática e Ecologia de Aves e Mamíferos Marinhos – LASBMAR – Depto de Zoologia, Universidade Federal do Rio Grande do Sul, RS – Brasil.

²Grupo de Estudos de Mamíferos Aquáticos do Rio Grande do Sul, Porto Alegre, RS, Brasil.

ABSTRACT

Aim Delphininae are the product of a recent and rapid radiation event and, currently, represent a challenge for systematics due to different aspects of its evolution that obscure the relationships among lineages. Here, is the first attempt to elucidate the drivers of the Delphininae radiation in the light of historical biogeography.

Location Atlantic, Indian and Pacific Oceans.

Methods Spatial analysis of vicariance (SAV) implemented in VIP (vicariance inference program) was conducted to search disjunctions for sister nodes in the Delphininae clade. We conducted the SAV with two different phylogenetic hypotheses, one based on morphological and another based on molecular data. An exhaustive revision of distribution of terminal taxa was conducted.

Results In both biogeographical analyses conducted in VIP, sister nodes disjunctions were recovered and hypothetical biogeographical scenarios were proposed. The separation of Delphininae and Steninae lineages seems to be related with the emergence of Central American Isthmus. Other disjunctions between terminal taxa seem to be related to soft barriers, such as the Benguela Upwelling System and the Eastern Pacific Barrier. Furthermore, the fragmentation of coastal habitats in Atlantic and Indo-Pacific basins, during Pleistocene glacial and interglacial cycles, played an important role in the adaptation of species to local niches and generation of diversity in the Delphinidae clade.

Main conclusions Biogeographical scenarios proposed in this study provide insights on the discussion about phylogenetic relationships in Delphininae clade. Through this study it is evident that it is possible to extract information about Delphininae lineages, despite incongruences of morphological and molecular hypotheses proposed to Delphininae clade and the recent proposal of synonymization of all taxa to *Delphinus*. Efforts should be concentrated in order to propose a new phylogenetic hypothesis for the Delphininae clade, covering both morphological as molecular, but also ecological data and the complete distribution of the taxa included in the analyses.

Keywords

Distribution, taxon history, oceanic barriers, vicariance, speciation.

¹ This article has been formatted according to the rules of the Journal of Biogeography, which we intend to submit this article after corrections.

INTRODUCTION

Cetaceans are descendants of a group of tetrapods that successfully adapted to the marine environment. Currently, 89 species of whales, dolphins and porpoises are recognized (Steeman *et al.*, 2009). Despite the diversity in the group, cetaceans are a monophyletic clade whose origin dates back to the Eocene (53 million years ago – Ma) in shallow and tropical waters of the extinct Tethys sea (Fordyce & Muizon, 2001; Fordyce, 2002a, 2003).

Evolution of cetaceans is marked by a long and informative fossil record and it is possible to recognize three major evolutionary radiations (Fordyce & Muizon, 2001). During the third radiation, studies based in molecular phylogenies revealed an increased speciation rate between 13 – 11 Ma and 6 – 4 Ma during diversification of modern cetaceans groups, as Ziphiidae, Delphinidae, Phocoenidae and Balaenopteridae (Steeman *et al.*, 2009; Slater *et al.*, 2010). In the fossil record of late Miocene (10-12 Ma), fossils identified as delphinids are found and, as a consequence of an adaptive radiation, resulted in a diverse, ecologically disparate clade (Barnes, 1990; Leduc *et al.*, 1999; Fordyce & Muizon, 2001; Caballero *et al.*, 2008; McGowen *et al.*, 2009; Steeman *et al.*, 2009; Slater *et al.*, 2010).

Delphinidae is the most speciose and versatile group of living cetaceans. Currently, there is no consensus on how many species belong to the clade, although some studies recognized the existence of 37 species (Caballero *et al.*, 2008; Amaral *et al.*, 2012a). Flower (1883) described the family as “perfectly natural one”, but the evolutionary relationships among dolphin species of Delphinidae are neither well understood nor agreed upon by all systematics 130 years later. The observation of LeDuc *et al.*, (1999), which the complex taxonomic history of the family Delphinidae is far from complete about how many species there are and describing them, what are relationships among species and to understand the ranges and patterns of intraspecific variation persist today.

There is a long debate about subdivisions within the Delphinidae and there is not agreement between phylogenetic hypothesis constructed from morphological and molecular evidences. The current use of subfamilies was proposed around morphological similarities of genera *Delphinus* (Delphininae), *Steno* (Steninae), *Lissodelphis* (Lissodelphinae), *Cephalorhynchus* (Cephalorhynchinae), and *Globicephala* (Globicephalinae) (Fordyce *et al.*, 2006). The first cladistic analysis proposed to Delphinidae was accomplished by LeDuc *et al.*, (1999) through cytochrome b gene data, suggesting the arrangement of genera into Delphininae, Lissodelphinae, Stenoninae, Globicephalinae subfamilies.

The subfamily Delphininae was proposed by many authors based in morphological characters (Fraser & Purves, 1960; Kasuya, 1973; Mead, 1975; Muizon, 1988). Perrin (1989) based in morphological similarities, proposed that *Lagenorhynchus*, *Grampus*, *Tursiops*, *Stenella*, *Delphinus*, and *Lagenodelphis* genera should be grouped into Delphininae. LeDuc *et al.*, (1999), based on mitochondrial data, suggested that *Delphinus*, *Lagenodelphis*, *Sousa*, *Stenella* and *Tursiops* genera should be integrated into the delphinine clade. Subsequent molecular studies basically differed in the proposed relationships between species and the inclusion of the genus *Sousa* (Caballero *et al.*, 2008; Kingston *et al.*, 2009; McGowen *et al.*, 2009; Steeman *et al.*, 2009; Slater *et al.*, 2010; McGowen, 2011; Amaral *et al.*, 2012a; Perrin *et al.*, 2013).

In early taxonomical reviews, as performed by Flower (1883), *Steno*, *Sotalia* and *Sousa* were classified together based in skull morphology, which *Sotalia* and *Sousa* sharing more similarities than with *Steno* (see Caballero *et al.*, 2008 to deeper revision). True (1889) clustered *Sotalia*, *Steno*, *Tursiops*, *Delphinus*, *Prodelphinus*, *Tursio*, *Lagenorhynchus*, *Sagmatias*, *Feresa*, *Cephalorhynchus*, *Neomeris*, *Phocoena*, *Grampus*, *Globicephalus* and *Pseudorca* in Delphininae. A morphological study performed by Fraser & Purves (1960) based in evolution of the accessory air sacs and ear, suggested the inclusion of *Tursiops*,

Stenella, *Delphinus*, *Lagenorhynchus*, *Grampus* and *Lagenodelphis* genera in Delphininae. In the same study, *Sousa* and *Steno* were included in Stenidae, due a combination of primitive and highly specialized features. Kasuya (1973) based on the morphology of tympano-periotic bone proposed that *Sotalia*, *Sousa* and *Cephalorhynchus* belonged to Sotallinae and *Tursiops*, *Stenella*, *Lissodelphis*, *Delphinus*, *Lagenorhynchus*, and *Steno* should be grouped in Delphininae. Mead (1975) based in anatomy of the external nasal passages and facial complex grouped *Delphinus*, *Stenella*, *Grampus*, *Tursiops*, *Lagenorhynchus*, *Lagenodelphis* and *Peponocephala* in Delphininae and suggested that *Steno* and *Sousa* should be placed in Steninae. This early studies were based on overall similarities and do not include any synapomorphies to the groups (Caballero *et al.*, 2008). Muizon (1988) performed an analysis of Delphinida relationships (not based on computer or other algorithm) and included in Delphininae the genera *Delphinus*, *Stenella*, *Tursiops*, *Grampus*, *Lissodelphis*, *Lagenodelphis*, *Lagenorhynchus*, *Steno*, *Sotalia* and *Sousa*. Bianucci (1996) described the fossil genera *Astadelphis* from Italian Pliocene sediments. The phyletic or phylogenetic relationships showed that *Astadelphis* was closed related to the *Steninae* and particularly to genus *Sousa*, which the affinities are in the shape of auditory bones. In morphological cladistic analysis performed by I.B. Moreno (Federal University of Rio Grande do Sul) , a well supported Steninae was found with four non-exclusive synapomorphies and included *Steno*, *Sousa* and *Sotalia*, which *Sousa* is the sister group to *Sotalia*.

Molecular studies taking on the hypothesis that *Sousa*, *Steno* and *Sotalia* are an artificial group that were created based on ancestral morphological characters (symplesiomorphies) (Leduc *et al.*, 1999, Caballero *et al.*, 2008). The first comprehensive molecular study of the Delphinidae was performed by LeDuc *et al.*, (1999) based on mitochondrial cytochrome b gene sequences. In this study, *Sousa chinensis* was well integrated into delphinine lineage and a Stenoninae clade (*Steno* and *Sotalia*) was recovered.

Subsequent molecular studies also agree with the inclusion of the genus *Sousa* in Delphininae (Caballero *et al.*, 2008; Kingston *et al.*, 2009; McGowen *et al.*, 2009; Steeman *et al.*, 2009; Slater *et al.*, 2010; McGowen, 2011; Vilstrup *et al.*, 2011; Amaral *et al.*, 2012a; Perrin *et al.*, 2013). Caballero *et al.*, (2008) investigated the phylogenetic placement of *Sotalia* using mitochondrial genes, autosomal introns and Y chromosome introns. The phylogenetic analysis of independent and combined datasets showed that *Sotalia* and *Sousa* fall within a clade containing other members of Delphininae, exclusive of *Steno*. *Sousa* was resolved as the sister taxon to *Sotalia* according to analysis of the nuDNA dataset but not in the analysis of the mtDNA or combined mtDNA +nuDNA datasets. Contrary, analysis of complete mitochondrial genome reveals that *Steno bredanensis* is phylogenetically more related to *Sotalia* dolphins (Cunha *et al.*, 2011).

Bianucci (2013) described *Septidelphis morri*, a new genus and species of true dolphin based in partial fossil skeleton. This fossil dolphin shares a combination of characters with *Sousa* and *Steno* and other two fossils species (*Austadelphis* and *Etruridelphis*). A phylogenetic analysis was performed including morphological characters and a molecular scaffold approach, which was used to sustain the clade including all extant delphinines, as strongly supported by most of published molecular phylogenetic analyses. The scaffold considers *Steno* to be basal to the other delphininds, as well as the sister group of *Sotalia* and that this two-species clade is the sister group of delphinines. The phylogenetic analysis placed *Septidelphis* inside the delphinines in a more apical position than *Sousa* but basal to the clade formed by all other delphinines. As reported by the author, *Septidelphis* together with *Astadelphis* and *Etruridelphis* might have originate between the divergence of *Sousa chinensis* and the clade formed by the other extant delphinines and the split of them into more clades.

Since the pioneering study of LeDuc *et al.*, (1999), the polyphyly of the *Stenella* genus is consensual, which some species are more closely related to others genus than to nominal congeners and, thus, these genera do not reflect the evolutionary relationships of the species they contain (see Perrin *et al.*, 2013 to a complete revision). Complete cytochrome b sequences recovered a well-supported clade into Delphininae, including *Stenella clymene*, *Stenella coeruleoalba*, *Delphinus delphis*, *Delphinus capensis*, *Stenella frontalis*, *Tursiops aduncus* (node “D”, Fig. 1, LeDuc *et al.*, 1999). In this study, *Stenella clymene* and *Stenella coeruleoalba* were close sister taxa. Furthermore, given the morphological similarities observed by Perrin *et al.*, (1987), LeDuc *et al.*, (1999) proposed that Indo-Pacific *Tursiops aduncus* and the Atlantic *Stenella frontalis* represented sister species and also suggested that *Tursiops truncatus* is the sister taxon to entire clade defined by node “D”. Perrin *et al.*, (1987) observed that *Stenella frontalis* in external size and shape is intermediate between *Stenella attenuata* and *Tursiops truncatus*, sharing many similarities to the *Tursiops truncatus* in external morphology of the rostrum, melon, flippers and dorsal fins, mainly with *Tursiops aduncus*. *Stenella frontalis* had a white background of dark ventral spots, rather than gray such as *Stenella attenuata*. Furthermore, it presents a spinal blaze and does not have a division of the peduncle into upper dark and lower light halves. *Tursiops truncatus* and *Stenella frontalis* share similar features, such a ventral margin of dorsal cape interrupted by spinal blaze. The mainly differences among these two species is relative to possession of dorsal spots, that are present in *Tursiops aduncus* (Perrin *et al.*, 1987). Perrin *et al.*, (1981) in redescription of *Stenella clymene*, observed that this species resembled *Stenella longirostris* externally and by spinner movements, while cranially it resembled *Stenella coeruleoalba* in shape. The anterior sinus (palatal grooves) that are well-developed in *Delphinus delphis* and *Lagenodelphis hosei* are also present in other species like *Stenella clymene*, *Stenella longirostris*, *Stenella coeruleoalba* and *Leucopleurus acutus* (I. B. Moreno, Federal

University of Rio Grande do Sul), although they may be weakly expressed in the last three species. In this way, was suggested that *Stenella frontalis*, *Stenella attenuata* and *Tursiops truncatus* shared a suite of cranial characters that separated them from the other delphinines such as *Stenella longirostris*, *Stenella clymene*, *Stenella coeruleoalba*, *Delphinus delphis* and *Lagenodelphis hosei* (Perrin *et al.*, 1981; Perrin *et al.*, 1987; Moreno, 2008b; Perrin *et al.*, 2013). In cladistic analysis performed by I. B. Moreno (Federal University of Rio Grande do Sul), a monophyletic *Tursiops* was recovered, which *Tursiops aduncus* and *Tursiops gephyreus* are sister taxa. In addition, *Tursiops* and *Stenella frontalis* share a suite of characteristics that support a sister-group relationship. *Tursiops* is closely related to *Stenella frontalis* with the same support as for the two subspecies of *Stenella attenuata* linked to each other. Also, *Stenella attenuata* + *Stenella graffmani* are the sister group to all remaining Delphininae. Morphologically, the skull of *Tursiops aduncus* is phenetically very similar to that of *Stenella frontalis* in shape and size. Furthermore, *Tursiops aduncus*, *Tursiops truncatus* and *Stenella frontalis* have several features (a medium zygomatic process of squamosal, a V-shape of the combined mandibles in ventral view and an intermediate anterior sinus) that differentiates them from the others delphinines I. B. Moreno, Federal University of Rio Grande do Sul).

McGowen *et al.*, (2009) phylogeny recovered in same clade *Stenella attenuata*, *Stenella longirostris* and *Lagenodelphis hosei*. In another clade, (*Tursiops aduncus*+*Tursiops truncatus*) was sister taxa of (*Stenella coeruleoalba* +*Stenella clymene*) to the exclusion of *Stenella frontalis*. By the first time in molecular phylogenies, a sister relationship was recovered between *Tursiops aduncus* and *Tursiops truncatus*, indicating a possible monophyly of *Tursiops* with weak support. A multi-locus phylogeny performed by Kingston *et al.*, (2009), recovered a sister taxon relationship between *Stenella attenuata* and *Stenella frontalis* species, congruent with morphological evidences. Although neither cytochrome b

phylogeny nor mtDNA control region indicate these sister taxa relationship (Leduc *et al.*, 1999, Kingston *et al.*, 2009). Furthermore, the multi-locus phylogeny groups *Stenella clymene* with *Stenella longirostris* and *Delphinus* to the exclusion of *Stenella coeruleoalba* (see Fig. 3A, Kingston *et al.*, 2009). In the phylogenetic analyses of Delphinidae using a short wavelength sensitive opsin gene sequence, a specific insertion sequence was found in *Delphinus capensis*, *Stenella longirostris*, *Stenella coeruleoalba*, *Lagenodelphis hosei* and *Sousa chinensis*. Furthermore, *Stenella frontalis* was closer to *Tursiops truncatus* than to others *Stenella* species (Koito *et al.*, 2010). In the topologies obtained in analyses performed by Amaral *et al.*, (2012a), the genus *Tursiops* was rendered a monophyletic sister group to *Stenella attenuata* and *Stenella frontalis* (Clade “B”, Fig. 3, Amaral *et al.*, 2012a).

Amaral *et al.*, (2014) conducted an investigation about the origin of *Stenella clymene* through natural hybridization between *Stenella longirostris* and *Stenella coeruleoalba* as earlier supposed by Perrin *et al.*, (1981). The mitochondrial genome of *Stenella clymene* is more closely related to that *Stenella coeruleoalba*, whereas the nuclear genome seems to be more closely related to *Stenella longirostris*. This result possibly indicates an ancient hybridization between a female *Stenella coeruleoalba* and a male *Stenella longirostris*. Currently, *Stenella clymene* is genetically differentiated from its parental species. Furthermore, a pattern of transgressive segregation is suggested to *Stenella clymene*, which new genetic associations lead to novel phenotypes that are able to explore new habitats and resources, promoting niche divergence (Amaral *et al.*, 2014). Additionally, species tree obtained with nuclear loci grouped a monophyletic *Tursiops* with *Stenella coeruleoalba*; recovered a sister taxa relationships between *Stenella frontalis* and *Stenella attenuata*; and indicated that *Stenella clymene* is phylogenetically closer to *Stenella longirostris*, *Lagenodelphis hosei* and *Delphinus*.

The difficulty of resolving phylogenetic relationships in the clade Delphininae is mainly attributed to historical aspects of the group, however, few studies have been carried out to date only trying to resolve the phylogenetic resolutions of delphinine dolphins. As pointed by Kingston *et al.*, (2009), Delphininae are the product of a recent and rapid radiation event. According to Bianucci (2013), the minimal age for the origin of the Delphininae clade based in fossils is 4 Ma, while molecular data suggest 3.84 Ma (2.57-5.23 Ma) (McGowen *et al.*, 2009) or 3.6 Ma (Cunha *et al.*, 2011). Although in the fossil record of any species referable to the genus *Tursiops* is at about 5 Ma (Barnes, 1990) or records referred to *Stenella*, *Tursiops* or *Delphinus* are attributed to Pliocene (Whitmore Jr, 1994; Bianucci, 1996; Fitzgerald, 2005; Bianucci, 2013). The diversification of the group began almost simultaneously during the Early Pliocene and continued through the Pleistocene (McGowen *et al.*, 2009). Lineages undergoing rapid radiations represent a challenge for systematics because few consistent morphological characters to produce a reliable phylogeny, possibly convergent evolution, retention of ancestral polymorphisms and hybridization that can obscure relationships among lineages (Kingston *et al.*, 2009; Amaral *et al.*, 2012a).

The ecological niches of cetaceans seem to be defined by water temperature, water depth and factors that affect the distribution and abundance of their prey (topography, ocean currents and primary productivity) (Baumgartner *et al.*, 2001; MacLeod, 2009). Although, the main influence on geographic ranges of cetacean species appears to be water temperature (MacLeod, 2009). Delphininae species predominantly inhabit tropical zone both in coastal and offshore habitats. Some species, as *Delphinus sp.*, *Lagenodelphis hosei*, *Stenella coeruleoalba*, *Tursiops truncatus*, are able to occupy higher latitudes and consequently can tolerate lower temperatures of water (Perrin *et al.*, 2009).

Regarding distribution, all oceanic basins are occupied by Delphininae species. Some species are endemic of Atlantic (e. g. *Stenella clymene*, *Stenella frontalis*, *Sousa teuszii*) or

Indo-Pacific basins (*Tursiops aduncus*, *Sousa chinensis*) (Perrin *et al.*, 1981; Fertl *et al.*, 2003; Van Waerebeek *et al.*, 2004; Moreno *et al.*, 2005b; Perrin *et al.*, 2007; Jefferson *et al.*, 2008; Mendez *et al.*, 2013). In a more refined taxonomic approach, recognized subspecies (*Stenella attenuata graffmani*, *Stenella longirostris centroamericana*, *Delphinus delphis ponticus*) and new taxa (*e.g.* *Tursiops australis*) are reported to local niches (Perrin, 1975, 1990, 2002a; Charlton-Robb *et al.*, 2011).

The old assumption abandoned by Flower (1883, p. 469): “upon which so many new species were founded, which limited the geographical area of each species to a small and circumscribed portion of the ocean, and placed imaginary barriers to its distribution” seems to agree with the thought that has been present in recent studies, which the species appear to be adapted to local niches and not worldwide distributed (Hoelzel, 1998; Tezanos-Pinto *et al.*, 2009; Morin *et al.*, 2010; Moura *et al.*, 2013). The geographic (*e. g.* Central American Isthmus closure) and climatic oscillations during Pliocene and Pleistocene could have acted as barriers to dispersal of many marine organisms promoting extinctions but also generating biodiversity (Hewitt, 2000; Briggs, 2003; Hewitt, 2004; Lessions, 2008; McGowen *et al.*, 2009; Steeman *et al.*, 2009; Amaral *et al.*, 2012b; Bianucci, 2013; Moura *et al.*, 2013).

Many studies have been trying to elucidate the relationships between species and understand the processes that led to the current diversity of cetaceans, but they fail in some aspects like covering the history of only one taxon - *e.g.* *Delphinus* (Amaral *et al.*, 2012b) 2012), *Tursiops* (Moura *et al.*, 2013), *Cephalorhynchus* , *Lagenorhynchus obscurus* (Harlin-Cognato *et al.*, 2007) - or excluding some taxa of analysis (Amaral *et al.*, 2012a), not sampling total distribution of a taxon (Moura *et al.*, 2013), or including only a genetic marker for some species on the data set (Mc Gowen *et al.* 2009, Steeman *et al.* 2009). All of these shortcomings can obscure the elucidation of the species relationships and processes that generate diversity in delphinine clade.

Here we apply the method of Spatial Analysis of Vicariance - SAV (Arias *et al.*, 2011) to find possible disjunctions between sister-taxa in Delphininae, using an extensive geographic distributional data of terminals present in two different phylogenetic hypotheses. This taxon history method is based in Hovenkamp's ideas that proposed the identification of vicariance events, which correspond to dispersal barriers separating biotas (Hovenkamp, 1997, 2001; Arias *et al.*, 2011). Hovenkamp (1997) suggests that to reconstruct the sequence of vicariance events are needed geographical and historical information and both types of data are presented in a cladistic analysis. The method requires neither a set of predefined areas nor assumptions of hierarchical relations between areas and it allows ignoring the distribution of the problematic nodes (*e.g.* widespread taxa). The main goal of SAV is to identify sister nodes with disjoint distributions (Arias *et al.*, 2011). SAV has been used in biogeographical analysis of different organisms – *e.g.* burrowing mayflies (Molineri & Salles, 2013), cave-dwelling rodent (Latinne *et al.*, 2012), amphilestid triconodont (Gaetano & Rougier, 2012), and spiders (Teixeira *et al.*, 2014) –, but this is the first attempt to the use the method in cetaceans and in the marine environment. It may seem surprising despite the apparent absence of barriers in the oceans when compared to terrestrial biomes and high dispersal capabilities of cetaceans.

In this study, our efforts were directed (1) to carry out an exhaustive geographic distribution revision of each terminal taxa, (2) to understand the mainly differences between morphological and molecular hypotheses of phylogenetic relationships in Delphininae clade; (3) to implement an unusual method in marine environment, regarding the apparent absence of barriers in oceans and marine speciation paradox (Bierne *et al.*, 2003), (4) to integrate historical, ecological, phylogenetic and geographic distribution approaches of delphinine dolphins, and finally (5) to search for climatic or geographic conditions that influenced the evolutionary history of the subfamily Delphininae.

MATERIAL AND METHODS

Data selection

Our study focuses in the subfamily Delphininae. To conduct this study, two phylogenetic hypotheses were employed, one performed by I. B. Moreno (Federal University of Rio Grande do Sul) and another conducted by McGowen *et al.*, (2009). Due to differences between phylogenetic proposals (morphological *vs.* molecular) we chose to use hypotheses that contemplate both evidence and to compare their results later.

Morphological hypothesis

The first attempt to produce a cladistic analysis of the Delphinidae using morphology was accomplished by I. B. Moreno (Federal University of Rio Grande do Sul). For the ingroup, all of the 17 genera of Delphinidae were represented with at least one species and taxa without full specific species status were also included. The ingroup thus totals 34 terminals (31 species + 3 subspecies + 1 population). A character matrix was constructed from a comprehensive morphological data set obtained from skull (including timpanoperiotics), external morphology and coloration. In total, 147 characters were utilized, which approximately 60 are original. A phylogenetic analysis was performed using the “parsimony ratchet” and resulted in four equally most parsimonious trees with a length of 1034 steps. In this analysis, Delphininae was recovered with 2 exclusive synapomorphies (the presence of the alisphenoid fossa for peribullary sinus and the protuberance on the medial edge of the internal acoustic meatus) and includes five genera: *Delphinus*, *Tursiops*, *Stenella*, *Lagenodelphis* and as a novelty, *Leucopleurus acutus*. The presence of *L. acutus* in this clade was surprising because this species is originally grouped with *Lagenorhynchus* or considered *incertae sedis*. A non-monophyletic *Stenella* was recovered, while the monophyly of *Delphinus* and *Tursiops* was found. Furthermore, a well supported Steninae was found

with four non-exclusive synapomorphies and included *Steno*, *Sousa* and *Sotalia*, which *Sousa* is the sister group to *Sotalia*.

The topology tree (Fig. 2) was provided by I. B. Moreno (Federal University of Rio Grande do Sul) and edited in Archeopteryx software (Han & Zmasek, 2009).

Molecular hypothesis

Since the pioneering study carried out by LeDuc *et al.*, (1999), several molecular phylogenies including Delphininae dolphins has been published (see Perrin *et al.*, (2013) for a deeper revision).

For the purpose of this study, we chose a molecular phylogeny performed by McGowen *et al.*, (2009) to Cetacea clade through supermatrix approach. This approach to systematics summarizes the strongest hierarchical signals in the character data and permits emergence of phylogenetic support that may not be apparent when analyzing different data sets independently. Furthermore, Bayesian supermatrix tree was utilized to estimate divergence dates among lineages (McGowen *et al.*, 2009).

The Bayesian topology (Fig. 3) was obtained in TreeBASE Web (<http://treebase.org/>) under accession number S10190 and edited in Archeopteryx software (Han & Zmasek, 2009). Regarding taxonomic confusion and lack of consensus on the distribution pattern of the genus *Delphinus*, we prefer to deal all data of this genus as *Delphinus sp.* and we collapsed the node in this topology.

Distribution Data

A review of general distribution patterns of all taxonomic units included in Delphininae was conducted. Posterior, an exhaustive literature review from publications after 1970 was performed to compile records of population and cases studies, sightings, incidental or intentional captures and strandings in order to include, as possible, the real distribution of each terminal present in each phylogeny. Geographic coordinates were estimated through

Google Earth where only locality information was available. Records with species misidentified, dubious or incomplete information were ignored.

Biogeographical Analysis

We used spatial analysis of vicariance (SAV), a taxon history method that chooses a set of distributional reconstructions in which cases of disjunction for sister nodes are maximized through an optimality criterion (Arias *et al.*, 2011). SAV is implemented in VIP (Vicariance Inference Program), a free computer program available at <http://www.zmuc.dk/public/phylogeny/vip/> (Arias, 2010).

To represent distributions as absence/presence data in each cell, was superimposed a bathymetry ocean map was obtained in NASA Earth Observations – NEO (<http://neo.sci.gsfc.nasa.gov/>) and we selected a grid of 2°x2° and maximum fill was adjusted to 1.

Biogeographical analyses were accomplished with morphological and molecular hypotheses. In the morphological approach we included 13 terminals of the Delphininae ingroup, and 4 taxa were used as external group. In the molecular approach we included 12 taxa as ingroup and 2 taxa as external group. Heuristic search to obtain the better reconstructions of disjunct pairs was conducted 1000 iterations under the default settings, except that the cost of distribution removal 1, and cost of partial removal (activated) 0.75. Searches using different grid size (1°x1°), maximum fill (2 and 3), different costs to partial or total removal of terminals and considering a 10%, 20% or 25% of max overlap were also conducted for comparative purposes, but the results were similar or with high scores.

RESULTS

Distribution Data

All available geographical records of terminals of both phylogenies were mapped (Fig. 1) and records with erroneous geographic information were excluded. In total, 2,655 records were selected to biogeographical analysis (Appendix 1).

Considering all taxonomic units described to Delphininae (Table 1), the Pacific Ocean has the highest number of taxa (37%), followed by Atlantic (35%) and Indian Ocean basins (28%). The Atlantic basin has the highest number of endemic species (46.6%), followed by Pacific (37.2%) and Indian basins (16.6%).

Table 1 Distribution of all taxonomic units described to Delphininae. Endemic taxa to each oceanic basin are underlined.

Oceans			
Subfamily	Pacific	Indian	Atlantic
Delphininae	<i>Delphinus capensis</i> <i>Delphinus delphis</i> <i>Lagenodelphis hosei</i> <i>Stenella attenuata</i> <u><i>Stenella attenuata graffmani</i></u> <i>Stenella coeruleoalba</i> <i>Stenella longirostris</i> <u><i>Stenella longirostris centroamericana</i></u> <u><i>Stenella longirostris orientalis</i></u> <u><i>Stenella longirostris roseiventris</i></u> <i>Tursiops aduncus</i> <u><i>Tursiops australis</i></u> <i>Tursiops truncatus</i>	<u><i>Delphinus capensis tropicalis</i></u> <i>Delphinus delphis</i> <i>Lagenodelphis hosei</i> <i>Stenella attenuata</i> <i>Stenella coeruleoalba</i> <i>Stenella longirostris</i> <i>Tursiops aduncus</i> <i>Tursiops truncatus</i> <i>Tursiops australis</i>	<i>Delphinus capensis</i> <i>Delphinus delphis</i> <i>Lagenodelphis hosei</i> <i>Stenella attenuata</i> <u><i>Stenella clymene</i></u> <i>Stenella coeruleoalba</i> <u><i>Stenella frontalis</i></u> <i>Stenella longirostris</i> <u><i>Tursiops qephyreus</i></u> <i>Tursiops truncatus</i>
Steninae	<i>Steno bredanensis</i>	<i>Steno bredanensis</i>	<u><i>Sotalia fluviatilis</i></u> <u><i>Sotalia quianensis</i></u> <i>Steno bredanensis</i>
Undefined	<i>Sousa chinensis</i> <u><i>Sousa spp.</i></u>	<i>Sousa chinensis</i> <u><i>Sousa plumbea</i></u>	<u><i>Sousa teuszii</i></u> <u><i>Leucopleurus acutus</i></u>
Endemic taxa	<u>6 (37.5%)</u>	<u>2 (16.6%)</u>	<u>7 (46.6%)</u>
TOTAL	16 (37%)	12 (28%)	15 (35%)

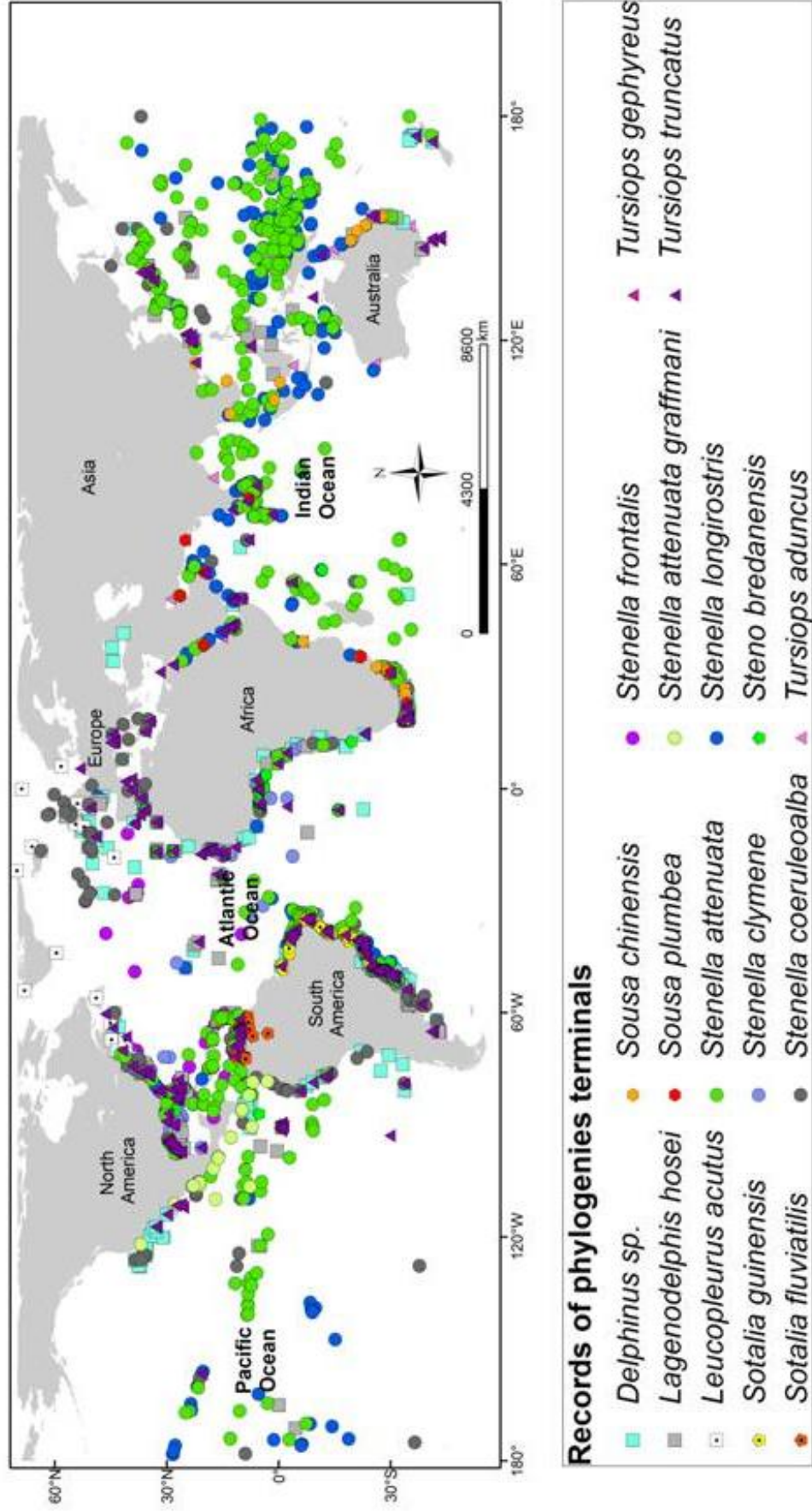

Figure 1 Map displaying all 2,655 records used in biogeographical analysis. More information about records in supplementary material (Appendix 1).

Biogeographical Analysis

Morphological data

The Spatial Analysis of Vicariance (SAV) performed in VIP found one reconstruction with cost of 9.5 (see Arias *et al.* 2011). The analysis show six and two alternative disjunct sister pairs and seven nodes with distribution removed (Fig. 2). An ancestral disjunction event was found in node 1 between Delphininae and Steninae clades. The second disjunction was in node 4 between *Tursiops* and *Stenella frontalis* clades. A third event separated *Tursiops aduncus* and *Tursiops gephyreus* (node 6). An alternative disjunction was founded between terminals *Stenella frontalis* northern and southern ecotypes (node 7). The fourth event was found in node 9, which separated (*Stenella longirostris*) and (*Leucopleurus acutus* (*Stenella clymene* (*Lagenodelphis hosei* + *S. coeruleoalba*))). The fifth event was found in external group in node 14, separating (*Steno bredanensis*) from (*Sotalia guianensis* (*Sousa chinensis* + *S. plumbea*)). In node 15, a second alternative event was found between (*Sotalia guianensis*) and (*Sousa chinensis* + *S. plumbea*). And the last event was found in node 16 separating *Sousa chinensis* from *Sousa plumbea* (see Fig. 3).

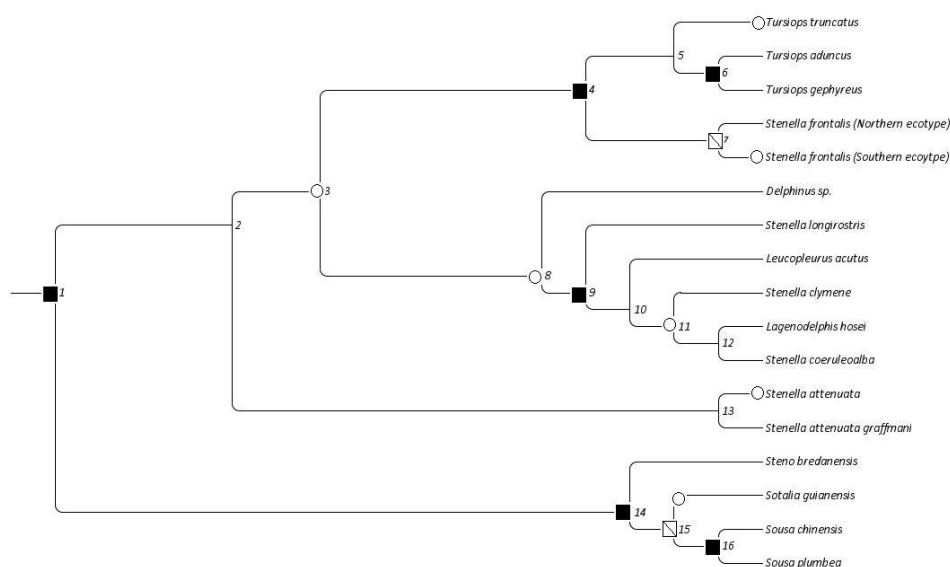

Figure 2 Delphininae topological tree modified from I. B. Moreno (Federal University of Rio Grande do Sul). Numbers below the branches identify the phylogenetic nodes. Symbols recovered by VIP: ■ Vicariance event; ▤ Alternative vicariance event; ○ Taxa distribution removed.

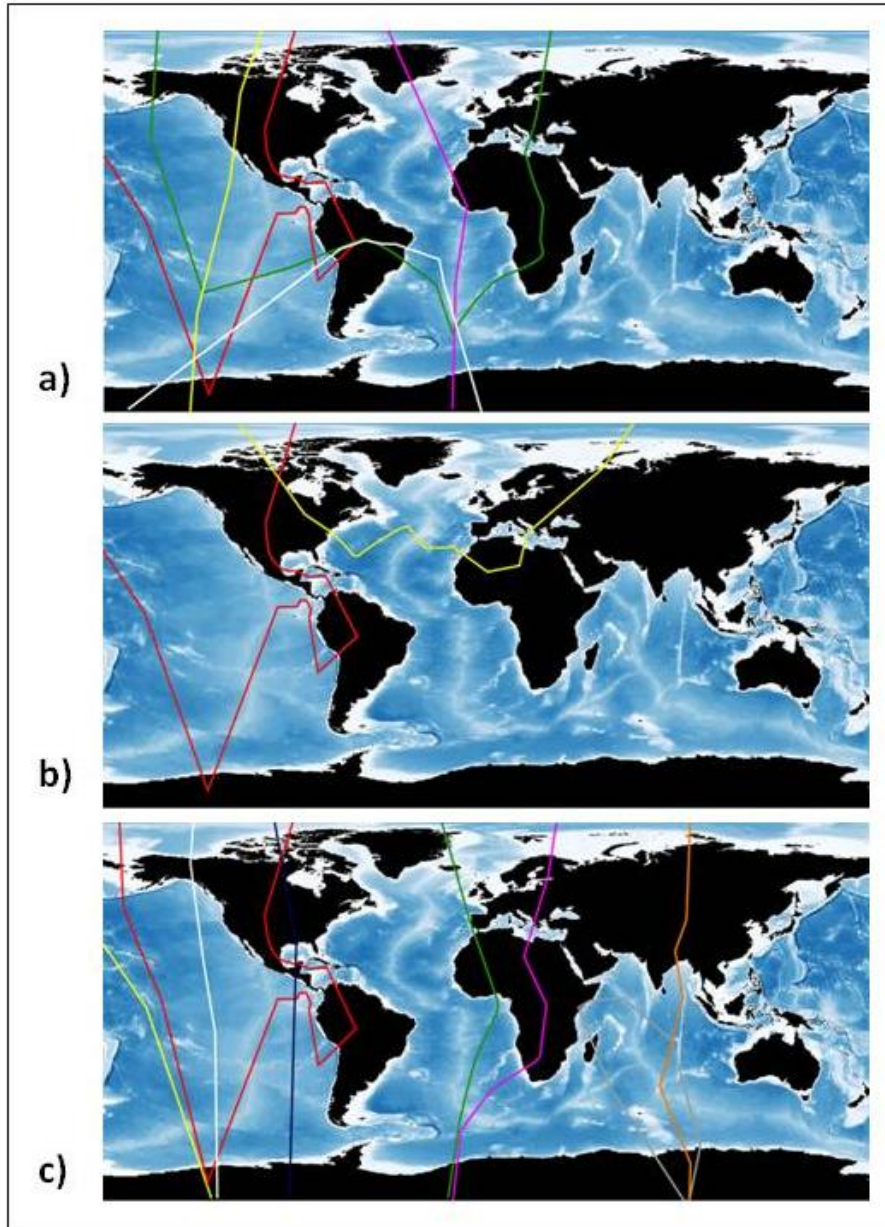

Figure 3 Disjunctions recovered by VIP from morphological data. Red lines in the maps a, b and c and indicate the basal event recovered in node, probably related to Panamanian Isthmus. In: A) Disjunctions found in Delphininae clade: green line indicate the disjunction found in node 4, probably related to Benguela Upwelling System; pink and yellow lines are disjunctions found in node 6 and seems to be related to the Benguela Upwelling System and the Eastern Pacific Barrier (EPB), respectively; white line is the alternative disjunction related to node 7 and it is related to fragmentation of Atlantic coastal habitat during glacial – interglacial cycles. B) Disjunction related to *Leucopleurus acutus*: yellow line indicate the disjunction recovered in node 9. C) Disjunctions founded in Steninae clade: pink, yellow and gray lines are disjunctions recovered in node 14 and related to Benguela Upwelling System and EPB; orange and dark blue lines indicate disjunctions founded in node 16 and probably related to fragmentation of Indian coastal habitat during glacial – interglacial cycles and EPB, respectively; green and white lines indicate the alternative disjunctions recovered in node 15 and related to Benguela Upwelling System and EPB.

Molecular data

Three reconstructions were stored by VIP from molecular tree with a cost of 7.75 (see Arias *et al.* 2011). In the consensus reconstruction three disjunct sister pairs, one alternative disjunct sister pair and five nodes with distribution removed were found (Fig. 4). A basal disjunction was recovered between the Delphininae clade and (*Sotalia fluviatilis* + *Sotalia guianensis*) (node 1). A second event was found in node 5, separating a ((*Tursiops truncatus* + *Tursiops aduncus*) + (*Stenella coeruleoalba* + *Stenella clymene*)) clade from (*Stenella frontalis*). The alternative event suggests a disjunction in node 6, separating (*Tursiops truncatus* + *Tursiops aduncus*) from (*Stenella coeruleoalba* + *Stenella clymene*). The third event was found in external group (node 11) and suggests a disjunction between *Sotalia fluviatilis* and *Sotalia guianensis* (see Fig. 5).

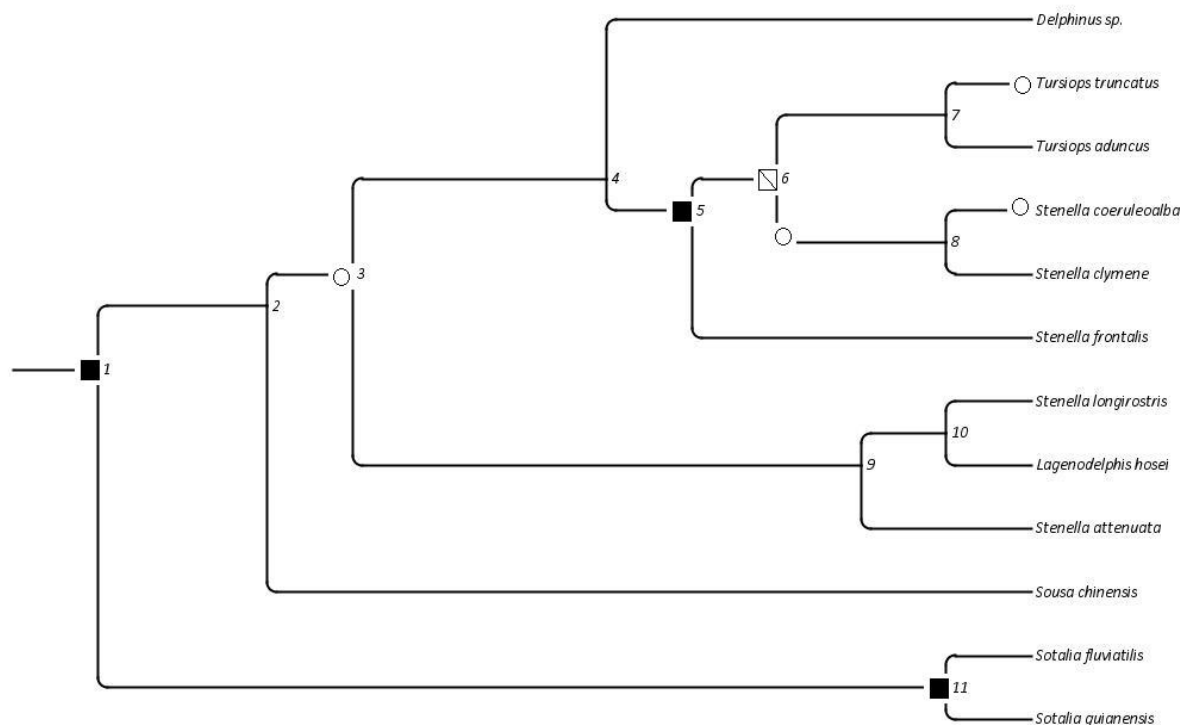

Figure 4 Delphininae topology tree modified from McGowen *et al.*, (2009). Numbers below the branches identify phylogenetic nodes. Symbols recovered by VIP: ■ Vicariance event; ▨ Alternative vicariance event; ○ Taxa distribution removed.

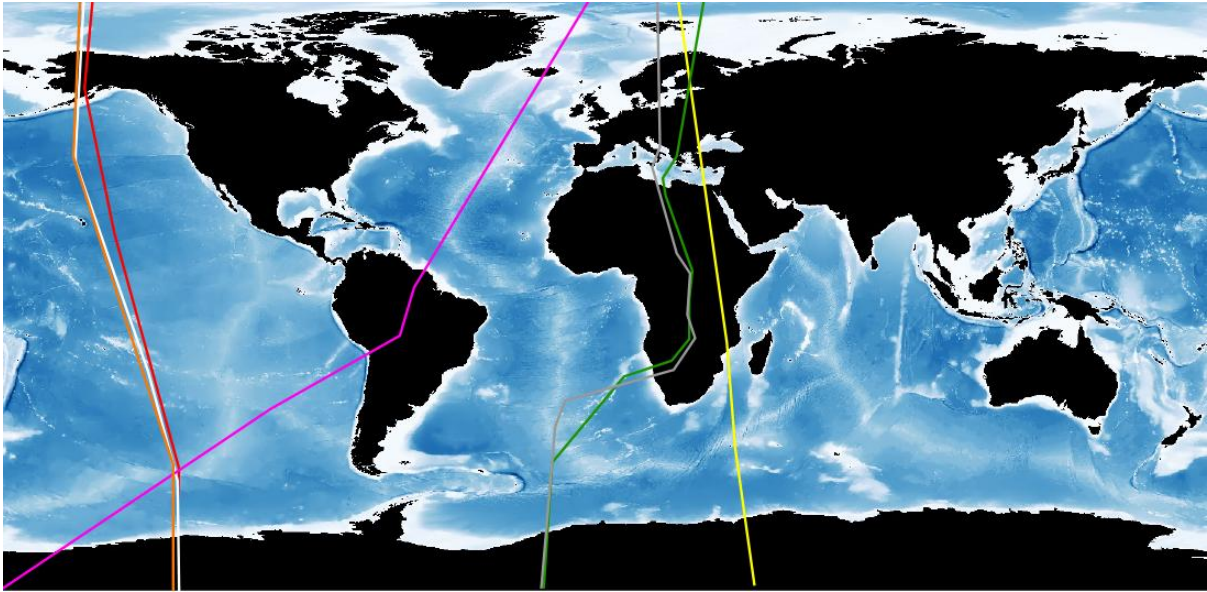

Figure 5 Disjunctions recovered by VIP in molecular approach. Yellow and red lines indicate the basal event recovered in node 1; green and white lines indicate the disjunction recovered in node 5; gray and orange lines indicate the alternative disjunction recovered in node 6; pink line indicates the disjunction founded in node 11 related to differences in marine coastal and riverine habitats. Probably, the yellow, green and gray lines are related to Benguela Upwelling System and the red, white and orange lines are related to EPB.

In both SAV, the first two basal disjunctions are related to Delphininae origin. In morphological approach, the separation of Delphininae clade and Steninae seems to be related with the rise of the Central American Isthmus that separates Caribbean and Pacific oceans. Conversely, in molecular approach, the disjunction that separates *Sotalia* clade of delphinine dolphins can be interpreted as the Benguela Upwelling System (in Eastern Atlantic) plus the Eastern Pacific Barrier (EPB).

In morphological approach, the disjunction events supported by the node 4 can be interpreted as Benguela Upwelling and the disjunction of node 6 can be related with the Benguela Upwelling System plus the EPB. The alternative vicariance event separating the *Stenella frontalis* northern and southern ecotypes can be related to the narrowing of the continental shelf north of Abrolhos Bank. The disjunction in the external group that separates *Steno bredanensis* from (*Sotalia guianensis* (*Sousa chinensis* + *Sousa plumbea*)), as well *Sotalia guianensis* from *Sousa* clade may be related with Benguela Upwelling System and the

EPB. The last event between *Sousa chinensis* and *Sousa plumbea*, can be related with habitat fragmentation during glacial-interglacial cycles in Indo-Pacific.

In molecular hypothesis, the disjunction events supported by the nodes 1, 4 and 5 can be interpreted as the same barrier found in morphological approach concerning to the nodes 4, 6,14 and 15 . The last event found separating *Sotalia fluviatilis* from *Sotalia guianensis* can be related to coastal and riverine ecological differences.

DISCUSSION

A number of studies have been published in the last decade trying to elucidate the drivers of the extant cetacean radiation through phylogenetic and demographic data, diversification rates and divergence times mainly associated with ecological and climatic changes of the Plio-Pleistocene (Pichler *et al.*, 2001; Natoli *et al.*, 2004; Natoli *et al.*, 2006; Harlin-Cognato *et al.*, 2007; Steeman *et al.*, 2009; Amaral *et al.*, 2012b; Moura *et al.*, 2013). On the other hand, here we try to discuss this question in the light of historical biogeography through the spatial analysis of vicariance methodology (Arias *et al.*, 2011).

SAV performed in VIP identified six and two alternative disjunct sister pairs in Moreno's morphological phylogeny and three and an alternative disjunctions events in McGowen's molecular phylogeny that we related to terrestrial or non-terrestrial (soft) barriers, like oceanic currents and climatic changes. Here, we build biogeographic hypothetical scenarios, one related to disjunctions recovered in morphological approach and other related to disjunctions found in molecular approach.

Delphininae origins – how the morphological and molecular phylogenetic hypothesis could help us?

Accepting the Moreno's morphological hypothesis, the events recovered by spatial analysis of vicariance can be interpreted such as the rise of the Central American Isthmus (a terrestrial barrier) and the others disjunctions are soft barriers such as the Benguela

Upwelling, the Eastern Pacific Barrier, water temperature fluctuations and fragmentation of coastal habitats as consequences of glacial-interglacial cycles during Pleistocene.

The emergence of Central American Isthmus (or Isthmus of Panama) has great potential to resolve interesting questions of historical biogeography (Macfadden, 2006) (2006), because no vicariant event is better dated than the isthmus (Lessios, 2008). Several physical changes were resulted of the closure of Panamanian land bridge, as currents flow, salinity, temperature and primary productivity (Briggs, 2003; Floeter *et al.*, 2008; Lessios, 2008). Furthermore, the Great American Interchange and the trigger of North Hemisphere Glaciations are the most recognized consequences of the emergence of the Isthmus of Panama and separation of Pacific-Caribbean waters (Marshall *et al.*, 1982; Lessios, 2008; Montes *et al.*, 2012). Keigwin (1978) suggested that Panamanian land bridge was completed by 3.1 – 3.6 Ma. However, this closure date estimation is mainly based on evolutionary divergence of marine organisms and therefore must be a minimum age (Farris *et al.*, 2011). Shallowing, coarsening-upward sequences were dated from 14.8 – 12.8 Ma and are interpreted to mark docking of the Panama block to northwestern South America (Coates *et al.*, 2004; Montes *et al.*, 2012). Coates *et al.*, (2004) suggested completion of the Central American arc collision with South America at about 7 Ma. Diverse evidences (*e.g.* isotopic, geochemical and faunal changes) in sedimentary strata on both sides of the isthmus have been used to narrow the timing of emergence and closure to between ca. 7 and 3.5 Ma (Montes *et al.*, 2012). In short, paleogeographic configuration suggests that the width of the seaway separating the Pacific and Caribbean waters since early Miocene was greatly restricted (Lessios, 2008; Montes *et al.*, 2012).

Conversely to Great American Interchange, the isthmus closure triggered a great schism in the sea, fragmenting the ranges of marine species that starting them on a path of independent evolutionary trajectories (Lessios, 2008). Another consequence due to the

Isthmus of Panama shutdown was the blocking of a tropical route, which used to link the Pacific and Atlantic oceans (Lessios, 2008). Connections between tropical organisms through circumglobal route has only been possible through Benguela Upwelling off Southwest Africa, since other possible routes via North and South American have been blocked by onset of cooled periods in late Pliocene. Furthermore, a seaway that connected the Indian Ocean to the Atlantic via Tethyan Sea had become completely closed in Middle Miocene (Briggs, 2003; Lessios, 2008) (Fig. 6).

Fossils assigned to extant genera as *Stenella*, *Delphinus* and *Tursiops* have Pliocene records with widespread geographic distribution (Barnes, 1990; Whitmore Jr, 1994; Bianucci, 1996; Fordyce & Muizon, 2001; Fitzgerald, 2005), suggesting that many cetacean taxa that are widely distributed in the world's oceans today were equally widespread during the Pliocene (Barnes, 1990; Fitzgerald, 2005).

The disjunction event detected by SAV from morphological data, which suggest the separation of the Caribbean Sea and Pacific Ocean was interpreted here as the rise of Central American Isthmus. In this way, we suggest that the Isthmus of Panama may have lead Delphininae evolution. In Moreno's hypothesis, the clade that placed together *Stenella attenuata* and *Stenella graffmani* seems to be diverged earlier in Delphininae lineage and *Steno bredanensis* is recognized by its plesiomorphic features (Barnes, 1990; Caballero *et al.*, 2008). Thus may be plausible that a large scale event and with the same age such as Isthmus of Panama (see previous discussion) may have played an important role in divergence of Delphininae and Steninae lineages through fragmentation of a hypothetical and widespread ancestor during Miocene-Pliocene transition. Although this hypothesis can still be premature because this event was recovered taking into account only *Stenella graffmani* and *Steno bredanensis* distributions and due to the gaps in current knowledge about taxonomy and phylogenetics relationships into Delphinidae.

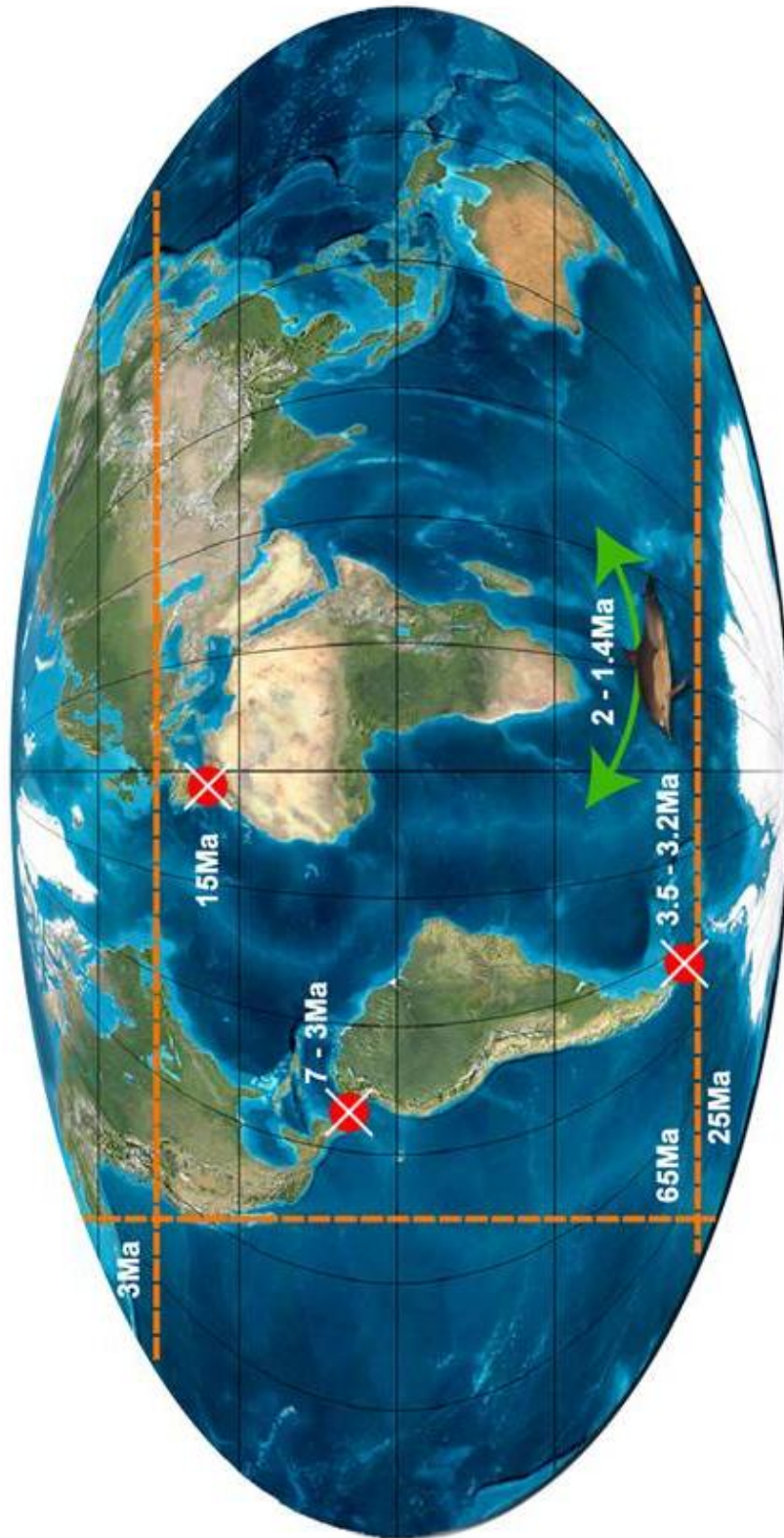

Figure 6 Terrestrial and soft permeable/impermeable barriers to delphinine dolphins. Modified from Briggs (2003) and Lessios (2008).

The most well-supported event disjunction (supported by 4, 6, 14 and 15 nodes of morphological hypothesis and by 1, 5 and 6 nodes of molecular hypothesis) is one that separates Indo-Pacific and Atlantic basins and, here, we suggest that barriers identified by

VIP are related to the Benguela Upwelling in Eastern Atlantic and the Eastern Pacific Barrier (EPB).

The Eastern Pacific Barrier (EPB) is a well-described soft barrier (non-terrestrial) of deepwater separating the eastern from the central Pacific and it is recognized as the World's widest marine biogeographic barrier (Briggs, 2003; Lessios & Robertson, 2006; Lessios, 2008). This barrier seems to be effective from 65 Ma ago and it is localized between Polynesia and American continent. Dispersal through the barrier is possible and, thus, the Eastern Pacific barrier can be considered a permeable filter (Briggs, 2003; Lessios & Robertson, 2006; Lessios, 2008).

The cetacean environment off Southern Africa that extending from the tropics to Antarctica and including the south-west Indian and the south-east Atlantic oceans encompasses a variety of circulatory regimes which affect cetacean distributions (*e.g.* currents, fronts, vertical stratification, biological productivity and chemical and physical constituents of sea water) (Ansonge *et al.*, 2007). In this region occurs the Benguela Upwelling System that is one of major upwelling systems and it is one of the most productive ecosystems in the world, supporting a large biomass of fish, crustaceans, sea birds and marine mammals (Andrews & Hutchings, 1980; Cohen *et al.*, 1992; Spalding *et al.*, 2012). The southern Benguela (south of 31°S) is dominated by a strongly seasonal regime. In the summer, upwelling events bring cold (8-10°C) water to surface (Cohen *et al.* 1992). Cool waters of Benguela Current Upwelling system move to north over the shelf in the Benguela Coastal Current, which converges with warm and saline waters of the Angola Current, at about 16°S, forming the convergence zone Angola-Benguela Front (Summerhayes *et al.*, 1995).

According Marlow *et al.* (2000), the sea surface temperature (SST) average of Benguela Upwelling for the mid-Pliocene (4.6 to 3.2 Ma) was 26°C, which is approximately

8°C warmer than the annual average SST of modern overlying waters and are similar to the average annual SST for the modern oligotrophic waters of the western South Atlantic (~25°C) at the same latitude. The Benguela upwelling system responded to the Plio-Pleistocene cooling transition with increased upwelling of nutrient-rich waters and shows a decline of ~10°C since 3.2 Ma. This phase of a prolonged gradual cooling (3.2 to 2.1 Ma, late Pliocene) is concomitant with the initiation of North Hemisphere Glacial. An apparent pause in the cooling trend is recorded at about 2.0 to 1.4 Ma. Sea surface temperature (SST) fluctuations are detected at 0.6 Ma and are similar to the 100-ky glacial-interglacial cycles. Thus, as suggesting by some authors the Atlantic tropical fauna has been isolated from the southern Indian Ocean by the Benguela Upwelling for at least 2 Ma (Floeter *et al.*, 2008; Lessions, 2008). Currently, the existence of an El Niño-type phenomenon is described in the Benguela System, which seasonal warming during late summer off northern and central Namibia is a regular occurrence and is due to the intrusion of warmer higher salinity water of Angolan origin into the region (Shannon *et al.*, 1986).

Briggs (2003) suggests as consequence of Pleistocene glacial stages, the Eastern Atlantic region is still in process of recovering from multiple extinctions. To this author, extinctions events can explain the poorest tropical biota of this region. Here, we hypothesized that Benguela Upwelling System is a soft permeable barrier for, at least, tropical Delphinids that during warm periods has promoted the exchange of tropical fauna between Atlantic and Indo-Pacific Oceans, but during cold periods has become an impermeable barrier that promotes the fragmentation of widespread taxa leading to allopatric speciation or local extinction.

In SAV conducted with McGowen's molecular hypothesis, the Benguela Upwelling System plus Eastern Pacific Barrier seems to be basal disjunctions that separate *Sotalia* genus of Delphininae lineage, which comprises *Sousa* genus. Taking on McGowen's molecular

hypothesis and its divergence date estimates we need to consider a hypothetical ancestor to *Sotalia* and Delphininae clade that dates at about 6.98 Ma (4.88 – 9.17 Ma). Cunha *et al.* (2011) dated the divergence of Delphininae clade to Stenoninae (*Steno* + *Sotalia*) at about 7.1 Ma. To build a biogeographical scenario supported by disjunctions recovered by SAV that indicated a barrier between Atlantic and Indo-Pacific and that, in this study, we interpreted as Benguela Upwelling plus Eastern Pacific Barrier; we would have to assume that Benguela has acted as a barrier to cetacean dispersal at least since 7 Ma ago. This assumption seems unlikely, because the average SST of Benguela Upwelling for the mid-Pliocene (4.6 to 3.2 Ma) was 26°C and temperature decreases starting at about 3 Ma (Marlow *et al.*, 2000). In this way, the isolation between Atlantic and Indian Oceans seems to have occurred more recently at about 2 Ma (Floeter *et al.*, 2008; Lessions, 2008). In this sense, the molecular data do not provide enough resolution to infer the vicariant involved in the separation of the lineages that gave rise to Delphininae and Steninae. Furthermore, even with some shortcomings, the morphological phylogeny seems to have more information to resolve this issue.

The Benguela Upwelling System – only one gate or the main barrier of the tropical oceans?

Considering all 43 taxonomic units included in this study (see Table 1), seven species (*Delphinus delphis*, *Lagenodelphis hosei*, *Stenella attenuata*, *Stenella coeruleoalba*, *Stenella longirostris*, *Steno bredanensis* and *Tursiops truncatus*) are widely distributed in the Atlantic, Indian and Pacific Oceans. Despite the connection with Atlantic and Pacific basins, the Indian Ocean harbors the lower number of tropical dolphins (n=12, Table 1), which only *Sousa plumbea* and *Delphinus capensis tropicalis* are exclusive to this basin (Perrin, 2002a; Frère *et al.*, 2008; Jefferson *et al.*, 2008; Amaral *et al.*, 2012b; Mendez *et al.*, 2013). The Pacific and Indian oceans share two species: *Sousa chinensis* and *Tursiops aduncus*, that are not present in the Atlantic Ocean. Rule out Indian Ocean, *Delphinus capensis* is the only species shared by Atlantic and Pacific Oceans, which may mean poor taxonomic resolution

given the lack of connection at low latitude between the two basins since the closure of the Isthmus of Panama. The Pacific endemic subspecies are found in Eastern Tropical Pacific *Stenella attenuata graffmani* (Perrin, 1975), *Stenella longirostris centroamericana*, *Stenella longirostris orientalis* and *Stenella longirostris roseivetris* (Perrin, 1990; Andrews *et al.*, 2013) and surrounding of Australia (*Tursiops australis* (Charlton-Robb *et al.*, 2011) and *Sousa spp.* (Frère *et al.*, 2008; Mendez *et al.*, 2013). Although this can be bias due of the more concentrated effort research in these areas than in others.

The Atlantic basin harbors 15 recognized taxa, which seven are endemic (Table 1). Despite their nearness to each other, the Atlantic and the Indian basins have very different dolphin faunas (Perrin & Best, 2007). The differences in dolphin fauna between Atlantic and Indian Oceans has been assigned to the Southern tip of Africa that act as barrier for tropical marine animals, allowing them to evolve independently. Such as suggested by Perrin & Best (2007), the Southern African is an open gate, allowing sporadic movement of tropical cetaceans between the Atlantic and Indian basins.

A disjunction between Atlantic and Indian oceans was identified by SAV in six sister nodes in both morphological and molecular approaches. In this study, this vicariance event was recognized as the Benguela Upwelling system and we suggest that permeability of this soft barrier during Pleistocene have led to diversification in Delphininae lineage, as well as to others marine species (Briggs, 2003; Floeter *et al.*, 2008; Teske *et al.*, 2014). On the other hand, Southern Africa was a breakpoint of a cooled corridor connecting South America to New Zealand, promoting dispersal of temperate dolphins such as *Lagenorhynchus obscurus* (Harlin-Cognato *et al.* 2007).

In SAV analysis performed in morphological hypothesis, the Benguela Upwelling was indicated as disjunction separating (*Tursiops truncatus* (*Tursiops aduncus*+*Tursiops gephyreus*)) from *Stenella frontalis*. To recover this event, a worldwide distribution of

Tursiops truncatus was discarded. This same barrier was identified as subsequent disjunction between sister nodes *Tursiops aduncus* and *Tursiops gephyreus* (node 6). The same disjunction involving a barrier between Atlantic and Indian basin has also been recovered between *Stenella frontalis* and *Tursiops* in McGowen's molecular phylogeny. It separates a ((*Tursiops truncatus* + *Tursiops aduncus*) + (*Stenella coeruleoalba* + *Stenella clymene*)) clade from *Stenella frontalis*. But to find this event, VIP consider only *Stenella frontalis* and *Tursiops aduncus* distributions, does not including distributional data of *Tursiops truncatus*, *Stenella coeruleoalba* and *Stenella clymene*. In addition, VIP suggests an alternative event in node 6, separating (*Tursiops truncatus* + *Tursiops aduncus*) from (*Stenella coeruleoalba* + *Stenella clymene*). This alternative event probably was recovered due very similar distributions of *Stenella frontalis* and *Stenella clymene*.

Despite discordant relationships among taxa given molecular and morphological approaches, to recover a disjunction in both phylogenies were just considered the distributions of *Tursiops aduncus* and *Stenella frontalis* restricted to Indo-Pacific and Atlantic basin, respectively. As presented in the introduction, there is no consensus regarding phylogenetic relationships involving these species and more studies are needed to clarify the placement of *Stenella* species into Delphininae. Given the limitations of the analysis, we suggest a biogeographical scenario based in morphological approach: after a basal disjunction identified in node 1 that are related to closure of Panamanian Isthmus at about 7 - 3.5 Ma, is plausible to assume the lineage that originate *Stenella frontalis* possible emerged in Indo-Pacific basin and was able to occupy Atlantic basin in warmer periods via Benguela gate at about 4 - 3Ma, probably before its cooling. According, morphological similarities between *Tursiops aduncus* and *Stenella frontalis*, we can think that this species shared a common putative ancestor that after a vicariance event underwent an allopatric speciation. However, SAV founded a later disjunction between *Tursiops aduncus* and *Tursiops*

gephyreus (node 6). A reinvasion of *Tursiops aduncus* lineage may be occurred in Atlantic during the cooling break at about 2 – 1.4 Ma (Marlow *et al.*, 2000; Lessions, 2008) or more recently during SST fluctuations due glacial-interglacial cycles in Benguela Upwelling, and yielding *Tursiops gephyreus* restricted to Southwestern Atlantic.

In the morphological hypothesis, the Benguela Upwelling plus Eastern Pacific Barrier seems to be involved in disjunctions of sister nodes into Steninae (Fig. 4C). An event was found in node 14, separating (*Steno bredanensis*) from (*Sotalia guianensis* (*Sousa chinensis* + *S. plumbea*)). In node 15, an alternative event was found between (*Sotalia guianensis*) and (*Sousa chinensis* + *Sousa plumbea*). If we consider all morphological evidences that *Sotalia*, *Sousa* and *Steno* are closely related and are a monophyletic clade, it is possible to think in a biogeographical scenario considering a widespread and pelagic ancestor to *Steno*, *Sotalia* and *Sousa* genera that was fragmented by establishment of Benguela Upwelling System in Eastern Atlantic at about 4 -3 Ma ago, subsequent to event that separated Delphininae and Steninae lineages due closure of Panamanian Isthmus. Thus, the putative ancestor of *Sotalia* was restricted to Atlantic basin, while *Sousa* ancestor was established in Indian-Pacific basin. Furthermore, the alternative event recovered in node 15 can be explained by this same way.

Although not including any of the analyses, the isolated distribution of *Sousa teuszii* in Eastern Atlantic was a posterior dispersal on this barrier during probably glacial-interglacial cycles in warm periods following by fragmentation in cool periods, yielding allopatric speciation of *Sousa teuszii* in coastal waters of Eastern Atlantic (Mendez *et al.*, 2013). As disjunction recovered by SAV in node 16 of morphological hypothesis may be explained by the fragmentation of tropical zone during Pleistocene following by adaptation to coastal niches that resulted in different species of and *Sousa* in Indo-Pacific basins (Voris, 2000; Mendez *et al.*, 2013).

Leucopleurus acutus – incertae sedis or a Delphininae member?

The analysis performed I. B. Moreno (Federal University of Rio Grande do Sul) was the first attempt to produce a cladistic analysis of the family Delphinidae using morphology with a comprehensive data set (skull, tympano-periotic, external morphology and coloration). Some characters are new in the sense that they were never used before in a cladistic analysis to resolve the phylogeny of Delphinidae. The presence of *Leucopleurus acutus* in this clade was surprising because this is one of the first times that this species is grouped with *Stenella*, *Delphinus* and *Lagenodelphis*. With two exclusive synapomorphies (the presence of the alisphenoid fossa for peribullary sinus and the protuberance on the medial edge of the internal acoustic meatus), the subfamily Delphininae includes five genera: *Delphinus*, *Tursiops*, *Stenella*, *Lagenodelphis* and as a novelty, *Leucopleurus acutus*. This last species shares a suite of morphological characters that place it close to other Delphininae. For example, the presence of long anterior sinus ventrally on the maxilla (unique in this clade) and the sigmoid shape of mandibles are some lines of evidence that this species could be a Delphininae.

As previously discussed, earlier morphological studies placed *Lagenorhynchus* genus in Delphininae (True, 1889; Fraser & Purves, 1960; Kasuya, 1973; Mead, 1975; Muizon, 1988). Perrin, (1989) in a classification of the family Delphinidae grouped all six species of *Lagenorhynchus* (*L. albirostris*, *L. acutus*, *L. obscurus*, *L. obliquidens*, *L. cruciger* and *L. australis*) in Delphininae, as well as, *Grampus*, *Tursiops*, *Stenella*, *Delphinus* and *Lagenodelphis* genus.

Dolphin species traditionally assigned to the genus *Lagenorhynchus* are found in a cool-temperate oceans and was recognized by its markedly antitropical distribution pattern (Cipriano, 1997; Harlin-Cognato & Honeycutt, 2006). *Leucopleurus acutus* is commonly named Atlantic white-sided dolphins and are an oceanic dolphin endemic to temperate and subpolar waters of the North Atlantic Ocean (Cipriano, 2009; Mirimin *et al.*, 2011).

Leucopleurus acutus and *Lagenorhynchus albirostris* are sympatric in North Atlantic (Cipriano, 1997).

Preliminary analysis about speciation in dolphins of the genus *Lagenorhynchus* indicated a non-monophyletic group that an early divergence within the Delphinidae gave rise to a variety of lineages in the mid-Miocene (Cipriano, 1997). The divergence times involving *Lagenorhynchus* species were estimated between 5.2 – 13 Ma (Fig. 5, Cipriano, 1997).

None of the species placed in the genus *Lagenorhynchus* showed close relationships to the remaining delphininaes in Leduc *et al.*,(1999). Furthermore, the results obtained based in cytochrome b data reveals that *Lagenorhynchus* is an artificial group, which *Lagenorhynchus australis*, *Lagenorhynchus obscurus*, *Lagenorhynchus cruciger* and *Lagenorhynchus obliquidens* formed a group closely related to *Cephalorhynchus* and *Lissodelphis*. As *Lagenorhynchus acutus* did not show close affinity with *Lagenorhynchus albirostris*, neither close affinity to any other species, the available generic name for it was *Leucopleurus* (Gray 1866).

In contrast to LeDuc *et al.* (1999), analyses in study performed by Harlin-Cognato & Honeycutt (2006) recovered the monophyly of *Leucopleurus acutus* and *Lagenorhynchus albirostris* and support a close relationship of these species with the *Delphinus/Stenella/Tursiops* clade (Fig. 2, Harlin-Cognato & Honeycutt, 2006). However, an unpublished study suggested that a hypothesis which proposes that *Leucopleurus acutus* and *Lagenorhynchus albirostris* are not closely related to each other and that *Lagenorhynchus acutus* is basal in the phylogeny of delphinids should be preferred. In addition, the divergence of these two species probably started at 6 Ma (E. Banguera-Hinestroza, Durham University). Furthermore, the study proposes hypothesis about dispersal and speciation in the current genus *Lagenorhynchus*, which the most recent common ancestor to *Leucopleurus acutus* and *Lagenorhynchus albirostris* living at about 6.53 Ma during late Miocene – early Pliocene and

probably dispersed into Pacific via Bering Strait or via Panamic sea way (E. Banguera-Hinestroza, Durham University).

In molecular analysis of McGowen *et al.*, (2009), *Leucopleurus acutus* represent an earlier divergent lineage of Delphinidae at about 9.39 Ma. In topologies supported by analyses of molecular and morphological data performed by Geisler *et al.*, (2011), *Leucopleurus acutus* is positioned as sister species to all other delphinids, with *Orcinus orca* branching from a more apical node as sister to all delphinids, except *Leucopleurus acutus*. In addition, the divergence between *Leucopleurus acutus* and remaining delphinids was estimated at about Miocene (Geisler *et al.*, 2011).

In SAV analysis of Moreno hypothesis, a disjunction involving *Leucopleurus acutus* was found in node 9, which separated *Stenella longirostris* from (*Leucopleurus acutus* (*Stenella clymene* (*Lagenodelphis hosei* + *S. coeruleoalba*)). To recover this event, VIP considered only *Stenella longirostris* and *Leucopleurus acutus* distributions. Regarding, incongruence about placement of *Leucopleurus acutus* in Delphinidae, we believe that any biogeographical scenario considering this species as a member of Delphininae is still premature.

Southwest Atlantic Ocean (SWA) – An important endemism area?

The southwest Atlantic Ocean (SWA) such as defined by Moreno *et al.*, (2005), includes waters south of Equator and west of 20°W. The main currents of the SWA are the South Equatorial, Brazil and Malvinas (Seeliger *et al.*, 1997). The Brazil Current and the North Brazil Current originate of split the South Equatorial Current in the northern coast of South America. The North Brazil Current runs northwest parallel to the northern coast of South America towards the Amazon basin and the Caribbean (da Silveira *et al.*, 1994). The Brazil Current, a oligotrophic current with high sea-surface temperature (22 to 30°C) and salinity (34 to 36‰), flows south along the continental slopes of eastern coast of South

America to a point between 33°S and 40°S where it encounters the northward flow of the Malvinas Current. The Malvinas Current, a nutrient-rich current with lower temperature (14 to 18°C) and salinity (33‰), originates as a branch of the Antarctic Circumpolar Current (Olson *et al.*, 1988; Matano *et al.*, 1993; Seeliger *et al.*, 1997). The Brazil and the Malvinas currents converge between 32 and 40°S and are forced offshore, giving rise to the Subtropical Convergence in the SWA (Stramma & Peterson, 1990; Seeliger *et al.*, 1997) that is one of the most energetic regions in the world ocean (Matano *et al.*, 1993). The meeting of these different masses generates gradients of temperature, salinity, density and nutrient content (Laprida *et al.*, 2011). The Subtropical Convergence has an important influence on the ecosystem of a large portion of the continental shelf and the slope between southern Brazil and Uruguay (34°40'S) (Seeliger *et al.*, 1997; Moreno *et al.*, 2005a). Modern SST values of Malvinas current oscillate around 11.8°C – 19°C between winter and summer, but the SST average estimated for the period between 0.3 and 0.12 Ma is ca. 8°C in winter, and 13°C in summer, which correspond to a cooling of 6-4°C during this time span (Laprida *et al.*, 2011). In addition, a possible displacement of the Subtropical Convergence zone to north, superficial waters of subantarctic origin to lower latitudes and a weakening of Brazil Current is suggested during this Middle Pleistocene cold period (Laprida *et al.*, 2011).

In SAV analysis, two disjunctions were founded in SWA in both molecular and morphological approaches. Disjunction recovered by SAV in molecular phylogeny is related to sister taxa *Sotalia fluviatilis* and *Sotalia guinensis*. In morphological approach, the vicariance event founded seems to isolate a population of *Stenella frontalis* in SWA.

For a long time, the specific status of marine and riverine ecotypes of *Sotalia* genus was uncertain along the Brazilian coast (Cunha *et al.*, 2005; Caballero *et al.*, 2007). Cunha *et al.*, (2005) conducted phylogenetic analyses and analysis of molecular variance of control region sequences and showed that marine and riverine ecotypes form very divergent

monophyletic groups and conclude that are different species, recommending the revalidation of *Sotalia guianensis* for the marine dolphins and retention the species name *Sotalia fluviatilis* to riverine dolphins. Furthermore, the populations of *Sotalia guianensis* showed a strong subdivision along Brazilian coast, with at least three evolutionary significant units: north, northeastern and south/southeastern (Cunha *et al.* 2005).

Sotalia guianensis occurs in coastal waters from West Atlantic, from southern Brazil to Honduras and *Sotalia fluviatilis* inhabits the Amazon River along Ecuador, Colombia and Peru (Romero *et al.*, 2001; Cunha *et al.*, 2005; Caballero *et al.*, 2007). Cunha *et al.*, (2005) estimated the divergence times between two species at about 5- 2.5 Ma during Pliocene and suggested that during the highest marine transgression event (2.5 Ma) *Sotalia* colonized the Amazon basin as consequence of freshwater inflow due sea level oscillations. However, the study conducted by Caballero *et al.*, (2007) suggested a more recent divergence between coastal and riverine *Sotalia* at about 1-1.2 Ma, although has also been attributed to marine transgressions and regressions that occurred in the Amazon basin at later Pliocene and during the Pleistocene as the vicariance event leading allopatric speciation of these sister taxa.

Atlantic spotted dolphin *Stenella frontalis* is the only species of *Stenella* that shows strictly coastal habits in SWA, occurring over continental shelf and slope up to 1000 m depth. Sightings and strandings in Rio Grande do Sul state (about 30°S) corresponds to Subtropical Convergence zone, suggesting that specie ranges their distribution limits seasonally, occurring at southernmost area in summer following Brazil Current (Moreno *et al.*, 2005). Moreno *et al.*, (2005) observed an absence of records of *Stenella frontalis* between 6 and 21°S and suggested that this species has a discontinuous distribution along the coast of Brazil and proposed the existence of two subpopulations in Brazilian coast, one occurring in southeastern and other in northern region of Brazil. Recently, the species was recorded in Abrolhos Bank next to 18°S (Danilewicz *et al.*, 2013). Environmental requirements of

southeastern coastal population seems to be different to north population (K. B. do Amaral, Federal University of Rio Grande do Sul) environmental requirements of southeastern coastal population seems to be different to north population as suggested by morphological (Moreno *et al.*, 2005) and molecular data (Caballero *et al.*, 2013). In study performed by Adams & Rosel (2006), different populations of *Stenella frontalis* in western North Atlantic are related to well known biogeographic transitions zones, as contemporary barriers of temperature and hydrography as well as historical climatic changes leading sea level fluctuation and hydrographic shifts during Pleistocene glaciations or earlier glacial episodes. By this way, the disjunction recovered by SAV between the forms north and south of *Stenella frontalis* may be related to sea level fragmentation of coastal environment along fluctuations in SWA sea level e temperature during glacial-interglacial cycles.

Another interestingly pattern, is the case of the endemic species of *Tursiops* in SWA. *Tursiops gephyreus* was described by Lahille in 1908 based in two specimens, being synonymized later to *Tursiops truncatus* (Hershkovitz, 1966). An unpublished study based in sincranium morphological data and vertebral count of specimens from Brazil, Uruguay and Argentina revalidated *Tursiops gephyreus* that has a sympatric distribution with *Tursiops truncatus* in southern Brazil (J. C. Wickert, Federal University of Rio Grande do Sul). Furthermore, the taxonomic status of *Tursiops truncatus* (*sensu* Montagu 1823) occurring in Brazilian coast was suggested to represent a different taxon. Here we suggest that SST oscillations in Malvinas Current during Pleistocene have leaded to speciation of *Tursiops gephyreus* in SWA and, elapsed enough time to differentiate the two species adapted to distinct niches. Also it is very important to understand the relationships between the several ecotypes described in the genus *Tursiops* (Natoli *et al.*, 2004; Natoli *et al.*, 2006; Tezanos-Pinto *et al.*, 2009; Moura *et al.*, 2013).

Despite their high dispersal ability and the apparent continuity of the marine environment, cetacean species exhibit fine-scale population structure (Qu  rouil *et al.*, 2010). Several studies postulated the existence of ecotypes or subspecies to widely distributed species, which are mainly related to offshore and coastal habitats or related to well structured populations within relatively small geographic areas (Natoli *et al.*, 2004; Escorza-Trevino *et al.*, 2005; Adams & Rosel, 2006; Natoli *et al.*, 2006; Morin *et al.*, 2010; Charlton-Robb *et al.*, 2011; Amaral *et al.*, 2012b; Andrews *et al.*, 2013; Mendez *et al.*, 2013; Moura *et al.*, 2013). In general, these studies showed a specialization of species to local niches, in other words, the marine environment is able to support the distribution of a species over a broad geographic range, however local variations in habitat could also leading to local niche specializations (Hoelzel, 1998). The SWA, the Benguela Upwelling System and the Australian coast seems to be important areas that promotes biological diversity given its environmental peculiarities. As previously suggested, it is possible the existence of endemic species in transition zones (McGowan, 1971; Spalding *et al.*, 2012). Furthermore, during climatic changes (*e.g.* Pleistocene glaciations), the distribution ranges of coastal marine species were restricted due the arising of physical barriers (*e.g.* oscillations in sea level and sea temperature) that reduced gene flow, even among adjacent populations, increasing the effect of evolutionary forces that drive speciation (*e.g.* genetic drift, selection and founder effects) (Hewitt, 2000; Hewitt, 2004; Banguera-Hinestroza *et al.*, 2010).

General considerations

In most studies, historical, ecological, geographic distribution and phylogenetic aspects of the Delphininae taxon are treated separately. However, this study attempts to explore these aspects simultaneously in order to understand the process involved in Delphininae evolution. Through this study it is evident that it is possible to extract information about Delphininae lineages, despite incongruences of morphological and

molecular hypotheses proposed to Delphininae clade and the recent proposal of synonymization of all taxa to *Delphinus*. Biogeographical scenarios proposed in the study provide insights on the discussion about phylogenetic relationships in Delphininae clade. Efforts should be concentrated in order to propose a new phylogenetic hypothesis for Delphininae clade, covering both morphological as molecular, but also ecological data and the complete distribution of the taxa included in the analyses.

REFERENCES

- Adams, L. & Rosel, P. (2006) Population differentiation of the Atlantic spotted dolphin (*Stenella frontalis*) in the western North Atlantic, including the Gulf of Mexico. *Marine Biology*, 148, 671-681.
- Amaral, A.R., Jackson, J.A., Möller, L.M., Beheregaray, L.B. & Manuela Coelho, M. (2012a) Species tree of a recent radiation: The subfamily Delphininae (Cetacea, Mammalia). *Molecular Phylogenetics and Evolution*, 64, 243-253.
- Amaral, A.R., Lovewell, G., Coelho, M.M., Amato, G. & Rosenbaum, H.C. (2014) Hybrid Speciation in a Marine Mammal: The Clymene Dolphin (*Stenella clymene*). *PLoS ONE*, 9, e83645.
- Amaral, A.R., Beheregaray, L.B., Bilgmann, K., Freitas, L., Robertson, K.M., Sequeira, M., Stockin, K.A., Coelho, M. & Möller, L.M. (2012b) Influences of past climatic changes on historical population structure and demography of a cosmopolitan marine predator, the common dolphin (genus *Delphinus*). *Molecular Ecology*, 21, 4854-4871.
- Andrews, K.R., Perrin, W.F., Oremus, M., Karczmarski, L., Bowen, B.W., Puritz, J.B. & Toonen, R.J. (2013) The evolving male: spinner dolphin (*Stenella longirostris*) ecotypes are divergent at Y chromosome but not mtDNA or autosomal markers. *Molecular Ecology*, 22, 2408-2423.
- Andrews, W. & Hutchings, L. (1980) Upwelling in the southern Benguela Current. *Progress in Oceanography*, 9, 1-81.
- Ansorge, I., Lutjeharms, J., Best, P. & Folkens, P. (2007) The cetacean environment off southern Africa. *The whales and dolphins of the southern African subregion*, 5-13.
- Arias, J.S. (2010) *Vicariance Inference Program - VIP*.
- Arias, J.S., Szumik, C.A. & Goloboff, P.A. (2011) Spatial analysis of vicariance: a method for using direct geographical information in historical biogeography. *Cladistics*, 27, 617-628.
- Banguera-Hinestroza, E., Bjørge, A., Reid, R., Jepson, P. & Hoelzel, A. (2010) The influence of glacial epochs and habitat dependence on the diversity and phylogeography of a coastal dolphin species: *Lagenorhynchus albirostris*. *Conservation Genetics*, 11, 1823-1836.
- Barnes, L.G. (1990) The Fossil Record and Evolutionary Relationships of the Genus Tursiops. *The Bottlenose dolphin* (ed. by S. Leatherwood and R.R. Reeves), pp. 3-26. Academic Press, San Diego.
- Baumgartner, M.F., Mullin, K.D., May, L.N. & Leming, T.D. (2001) Cetacean habitats in the northern Gulf of Mexico. *Fishery Bulletin*, 99, 219-239.

- Bianucci, G. (1996) The Odontoceti (Mammalia, Cetacea) from Italian Pliocene. Systematics and Phylogenesis of Delphinidae. *Palaeontographia italica*, 83, 73-767.
- Bianucci, G. (2013) *Septidelphis morii*, n. gen. et sp., from the Pliocene of Italy: new evidence of the explosive radiation of true dolphins (Odontoceti, Delphinidae). *Journal of Vertebrate Paleontology*, 33, 722-740.
- Bierne, N., Bonhomme, F. & David, P. (2003) Habitat preference and the marine-speciation paradox. *Proceedings: Biological Sciences*, 270, 1399-1409.
- Briggs, J.C. (2003) Marine centres of origin as evolutionary engines. *Journal of Biogeography*, 30, 1-18.
- Caballero, S., Santos, M.C.O., Sanches, A. & Mignucci-Giannoni, A.A. (2013) Initial description of the phylogeography, population structure and genetic diversity of Atlantic spotted dolphins from Brazil and the Caribbean, inferred from analyses of mitochondrial and nuclear DNA. *Biochemical Systematics and Ecology*, 48, 263-270.
- Caballero, S., Jackson, J., Mignucci-Giannoni, A.A., Barrios-Garrido, H., Beltrán-Pedrerros, S., Montiel-Villalobos, M.a.G., Robertson, K.M. & Baker, C.S. (2008) Molecular systematics of South American dolphins *Sotalia*: Sister taxa determination and phylogenetic relationships, with insights into a multi-locus phylogeny of the Delphinidae. *Molecular Phylogenetics and Evolution*, 46, 252-268.
- Caballero, S., Trujillo, F., Vianna, J., Barrios-Garrido, H., Montiel, M., Beltrán-Pedrerros, S., Marmontel, M., Santos, M., Rossi-Santos, M. & Santos, F. (2007) Taxonomic status of the genus *Sotalia*: Species level ranking for “tucuxi”(*Sotalia fluviatilis*) and “costero”(*Sotalia guianensis*) dolphins. *Marine Mammal Science*, 23, 358-386.
- Charlton-Robb, K., Gershwin, L.-a., Thompson, R., Austin, J., Owen, K. & McKechnie, S. (2011) A New Dolphin Species, the Burrunan Dolphin *Tursiops australis* sp. nov., Endemic to Southern Australian Coastal Waters. *PLoS ONE*, 6, e24047.
- Cipriano, F. (1997) Antitropical distributions and speciation in dolphins of the genus *Lagenorhynchus*: A preliminary analysis. *Molecular Genetics of Marine Mammals* (ed. by A.E. Dizon, S.J. Chivers and W.F. Perrin), pp. 305-316. Society for Marine Mammalogy.
- Cipriano, F. (2009) Atlantic white-sided dolphin, *Lagenorhynchus acutus*. *Encyclopedia of Marine Mammals* (ed. by W.F. Perrin, B. Wursig and J.G.M. Thewissen), pp. 56-58. Academic Press.
- Coates, A.G., Collins, L.S., Aubry, M.-P. & Berggren, W.A. (2004) The geology of the Darien, Panama, and the late Miocene-Pliocene collision of the Panama arc with northwestern South America. *Geological Society of America Bulletin*, 116, 1327-1344.
- Cohen, A.L., Parkington, J.E., Brundrit, G.B. & van der Merwe, N.J. (1992) A Holocene marine climate record in mollusc shells from the southwest African coast. *Quaternary Research*, 38, 379-385.
- Cunha, H.A., Moraes, L.C., Medeiros, B.V., Lailson-Brito, J., Jr., da Silva, V.M.F., Solé-Cava, A.M. & Schrago, C.G. (2011) Phylogenetic Status and Timescale for the Diversification of *Steno* and *Sotalia* Dolphins. *PLoS ONE*, 6, e28297.
- Cunha, H.A., Silva, V.M.F., Lailson-Brito, J., Jr., Santos, M.C.O., Flores, P.A.C., Martin, A.R., Azevedo, A.F., Fragoso, A.B.L., Zanelatto, R.C. & Solé-Cava, A.M. (2005) Riverine and marine ecotypes of *Sotalia* dolphins are different species. *Marine Biology*, 148, 449-457.
- da Silveira, I.C.A., de Miranda, L.B. & Brown, W.S. (1994) On the origins of the North Brazil Current. *Journal of Geophysical Research: Oceans*, 99, 22501-22512.

- Danilewicz, D., Ott, P., Secchi, E., Andriolo, A. & Zerbini, A. (2013) Occurrence of the Atlantic spotted dolphin, *Stenella frontalis*, in the southern Abrolhos Bank, Brazil. *Marine Biodiversity Records*, 6, 1-3.
- Emílsson, I. (1961) The shelf and coastal waters off southern Brazil. *Boletim do Instituto Oceanográfico*, 11, 101-112.
- Escorza-Trevino, S., Archer, F.I., Rosales, M., Lang, A. & Dizon, A.E. (2005) Genetic differentiation and intraspecific structure of eastern tropical Pacific spotted dolphins, *Stenella attenuata*, revealed by DNA analyses. *Conservation Genetics*, 6, 587-600.
- Farris, D.W., Jaramillo, C., Bayona, G., Restrepo-Moreno, S.A., Montes, C., Cardona, A., Mora, A., Speakman, R.J., Glascock, M.D. & Valencia, V. (2011) Fracturing of the Panamanian Isthmus during initial collision with South America. *Geology*, 39, 1007-1010.
- Fertl, D., Jefferson, T.A., Moreno, I.B., Zerbini, A.N. & Mullin, K.D. (2003) Distribution of the Clymene dolphin *Stenella clymene*. *Mammal Review*, 33, 253-271.
- Fitzgerald, E.M. (2005) Pliocene marine mammals from the Whalers Bluff formation of Portland, Victoria, Australia. *Memoirs of Museum Victoria*, 62, 67-89.
- Floeter, S.R., Rocha, L.A., Robertson, D.R., Joyeux, J.C., Smith-Vaniz, W.F., Wirtz, P., Edwards, A.J., Barreiros, J.P., Ferreira, C.E.L., Gasparini, J.L., Brito, A., Falcón, J.M., Bowen, B.W. & Bernardi, G. (2008) Atlantic reef fish biogeography and evolution. *Journal of Biogeography*, 35, 22-47.
- Flower, W.H. (1883) On the characters and divisions of the family Delphinidae. *Proceedings Zoological Society of London*, 466-513.
- Fordyce, R., Merrick, J., Archer, M., Hickey, G. & Lee, M. (2006) A southern perspective on cetacean evolution and zoogeography. *Evolution and Biogeography of Australasian Vertebrates. AusSciPub [Australian Scientific Publishing], Sydney*, 755-778.
- Fordyce, R.E. (2002) Fossil Record. *Encyclopedia of Marine Mammals* (ed. by W.F. Perrin, B. Würsig and J.G.M. Thewissen), pp. 453-471. Academic Press, San Diego.
- Fordyce, R.E. (2003) Cetaceans Evolution and Eocene-Oligocene Oceans Revisited. *From greenhouse to icehouse: the marine Eocene-Oligocene transition* (ed. by D.R. Prothero, L.C. Ivany and E.A. Nesbitt), pp. 154-170. Columbia University Press, New York.
- Fordyce, R.E. & Muizon, C.d. (2001) Evolutionary history of cetaceans: a review. *Secondary Adaptation of Tetrapods to Life in Water: Proceedings of the international meeting, Poitiers, 1996* (ed. by J.M. Mazin and V.D. Buffrénil), pp. 169-233. Verlag Dr. Friedrich Pfeil, München.
- Fraser, F.C. & Purves, P.E. (1960) *Hearing in cetaceans: evolution of the accessory air sacs and the structure and function of the outer and middle ear in recent cetaceans*. British Museum (Natural History).
- Frère, C.H., Hale, P.T., Porter, L., Cockcroft, V.G. & Dalebout, M.L. (2008) Phylogenetic analysis of mtDNA sequences suggests revision of humpback dolphin (*Sousa spp.*) taxonomy is needed. *Marine and Freshwater Research*, 59, 259-268.
- Gaetano, L.C. & Rougier, G.W. (2012) First Amphilestid from South America: A Molariform from the Jurassic Cañadón Asfalto Formation, Patagonia, Argentina. *Journal of Mammalian Evolution*, 19, 235-248.
- Geisler, J.H., McGowen, M.R., Yang, G. & Gatesy, J. (2011) A supermatrix analysis of genomic, morphological, and paleontological data from crown Cetacea. *BMC Evolutionary Biology*, 11, 112.
- Han, M.V. & Zmasek, C.M. (2009) phyloXML: XML for evolutionary biology and comparative genomics. *BMC Bioinformatics*, 10, 356.

- Harlin-Cognato, A. & Honeycutt, R. (2006) Multi-locus phylogeny of dolphins in the subfamily Lissodelphininae: character synergy improves phylogenetic resolution. *BMC Evol Biol*, 6, 87.
- Harlin-Cognato, A.D., Markowitz, T., Würsig, B. & Honeycutt, R.L. (2007) Multi-locus phylogeography of the dusky dolphin (*Lagenorhynchus obscurus*): passive dispersal via the west-wind drift or response to prey species and climate change? *BMC Evolutionary Biology*, 7, 131.
- Hershkovitz, P. (1966) Catalog of living whales.
- Hewitt, G. (2000) The genetic legacy of the Quaternary ice ages. *Nature*, 405, 907-913.
- Hewitt, G. (2004) Genetic consequences of climatic oscillations in the Quaternary. *Philosophical Transactions of the Royal Society of London. Series B: Biological Sciences*, 359, 183-195.
- Hoelzel, A. (1998) Genetic structure of cetacean populations in sympatry, parapatry, and mixed assemblages: implications for conservation policy. *Journal of Heredity*, 89, 451-458.
- Hovenkamp, P. (1997) Vicariance Events, not Areas, Should be Used in Biogeographical Analysis. *Cladistics*, 13, 67-79.
- Hovenkamp, P. (2001) A direct method for the analysis of vicariance patterns. *Cladistics*, 17, 260-265.
- Jefferson, T.A., Webber, M.A., Pitman, R. & (2008) *Marine mammals of the world: A comprehensive guide to their identification*. Academic Press, London.
- Kasuya, T. (1973) Systematic consideration of recent toothed whales based on the morphology of tympano-periotic bone. *Scientific Reports of the Whales Research Institute*, 25, 1-103.
- Keigwin, L.D. (1978) Pliocene closing of the Isthmus of Panama, based on biostratigraphic evidence from nearby Pacific Ocean and Caribbean Sea cores. *Geology*, 6, 630-634.
- Kingston, S., Adams, L. & Rosel, P. (2009) Testing mitochondrial sequences and anonymous nuclear markers for phylogeny reconstruction in a rapidly radiating group: molecular systematics of the Delphininae (Cetacea: Odontoceti: Delphinidae). *BMC Evolutionary Biology*, 9, 245.
- Koito, T., Kubokawa, K., Tanabe, S. & Miyazaki, N. (2010) Phylogenetic analyses in cetacean species of the family Delphinidae using a short wavelength sensitive opsin gene sequence. *Fisheries Science*, 76, 571-576.
- Laprida, C., Garcia Chaporri, N., Chiessi, C.M., Violante, R.A., Watanabe, S. & Totah, V. (2011) Middle Pleistocene sea surface temperature in the Brazil-Malvinas Confluence Zone: Paleoceanographic implications based on planktonic foraminifera. *Micropaleontology*, 57, 183-194.
- Latinne, A., Waengsothorn, S., Rojanadilok, P., Eiamampai, K., Sribuarod, K. & Michaux, J.R. (2012) Combined Mitochondrial and Nuclear Markers Revealed a Deep Vicariant History for *Leopoldamys neilli*, a Cave-Dwelling Rodent of Thailand. *PLoS ONE*, 7, e47670.
- Leduc, R.G., Perrin, W.F. & Dizon, A.E. (1999) Phylogenetic relationships among the delphinid cetaceans based on full cytochrome b sequences. *Marine Mammal Science*, 15, 619-648.
- Lessons, H.A. (2008) The great american schism: Divergence of marine organisms after the rise of Central American Isthmus. *Annual Review of Ecology, Evolution and Systematics*, 39, 63-91.
- Lessios, H.A. & Robertson, D.R. (2006) Crossing the impassable: genetic connections in 20 reef fishes across the eastern Pacific barrier. *Proceedings of the Royal Society B: Biological Sciences*, 273, 2201-2208.

- Macfadden, B.J. (2006) North American Miocene land mammals from Panama. *Journal of Vertebrate Paleontology*, 26, 720-734.
- MacLeod, C.D. (2009) Global climate change, range changes and potential implications for the conservation of marine cetaceans: a review and synthesis. *Endangered Species Research*, 7, 125-136.
- Marlow, J.R., Lange, C.B., Wefer, G. & Rosell-Melé, A. (2000) Upwelling Intensification As Part of the Pliocene-Pleistocene Climate Transition. *Science*, 290, 2288-2291.
- Marshall, L.G., Webb, S.D., Sepkoski, J.J. & Raup, D.M. (1982) Mammalian Evolution and the Great American Interchange. *Science*, 215, 1351-1357.
- Matano, R., Schlax, M. & Chelton, D. (1993) Seasonal variability in the Southwestern Atlantic. *Journal of Geophysical Research*, 98, 18,027-18,035.
- McGowan, J. (1971) Oceanic biogeography of the Pacific. *The Micropalaeontology of Oceans: Proceedings of the Symposium Held in Cambridge from 10 to 17 September 1967 Under the Title Micropalaeontology of Marine Bottom Sediments*.
- McGowen, M.R. (2011) Toward the resolution of an explosive radiation—A multilocus phylogeny of oceanic dolphins (Delphinidae). *Molecular Phylogenetics and Evolution*, 60, 345-357.
- McGowen, M.R., Spaulding, M. & Gatesy, J. (2009) Divergence date estimation and a comprehensive molecular tree of extant cetaceans. *Molecular Phylogenetics and Evolution*, 53, 891-906.
- Mead, J.G. (1975) Anatomy of the external nasal passages and facial complex in the Delphinidae (Mammalia: Cetacea). *Smithsonian Contributions to Zoology*, 207, 1-35.
- Mendez, M., Jefferson, T.A., Kolokotronis, S.-O., Krützen, M., Parra, G.J., Collins, T., Minton, G., Baldwin, R., Berggren, P., Särnblad, A., Amir, O.A., Peddemors, V.M., Karczmarski, L., Guissamulo, A., Smith, B., Sutaria, D., Amato, G. & Rosenbaum, H.C. (2013) Integrating multiple lines of evidence to better understand the evolutionary divergence of humpback dolphins along their entire distribution range: a new dolphin species in Australian waters? *Molecular Ecology*, 22, 5936-5948.
- Mirimin, L., Banguera-Hinestroza, E., Dillane, E., Hoelzel, A.R., Cross, T.F. & Rogan, E. (2011) Insights into genetic diversity, parentage, and group composition of Atlantic white-sided dolphins (*Lagenorhynchus acutus*) off the west of Ireland based on nuclear and mitochondrial genetic markers. *Journal of Heredity*, 102, 79-87.
- Molineri, C. & Salles, F.F. (2013) Phylogeny and biogeography of the ephemeral *Campsurus Eaton* (Ephemeroptera, Polymitaeridae). *Systematic Entomology*, 38, 265-277.
- Montes, C., Cardona, A., McFadden, R., Morón, S.E., Silva, C.A., Restrepo-Moreno, S., Ramírez, D.A., Hoyos, N., Wilson, J., Farris, D., Bayona, G.A., Jaramillo, C.A., Valencia, V., Bryan, J. & Flores, J.A. (2012) Evidence for middle Eocene and younger land emergence in central Panama: Implications for Isthmus closure. *Geological Society of America Bulletin*, 124, 780-799.
- Moreno, I.B., Zerbini, A.N., Danilewicz, D., Santos, M.C.d.O., Simões-Lopes, P.C., Jr., J.L.-B. & Azevedo, A.F. (2005) Distribution and habitat characteristics of dolphins of the genus *Stenella* (Cetacea: Delphinidae) in the southwest Atlantic Ocean. *Marine Ecology Progress Series*, 300, 229-240.
- Morin, P.A., Archer, F.I., Foote, A.D., Vilstrup, J., Allen, E.E., Wade, P., Durban, J., Parsons, K., Pitman, R., Li, L., Bouffard, P., Abel Nielsen, S.C., Rasmussen, M., Willerslev, E., Gilbert, M.T.P. & Harkins, T. (2010) Complete mitochondrial genome phylogeographic analysis of killer whales (*Orcinus orca*) indicates multiple species. *Genome Research*, 20, 908-916.
- Moura, A.E., Nielsen, S.C.A., Vilstrup, J., Moreno-Mayar, V., Gilbert, M.T.P., Gray, H.I., Natoli, A., Möller, L.M. & Hoelzel, A. (2013) Recent diversification of marine genus

- (*Tursiops* spp.) tracks habitat preference and environmental change. *Systematic Biology*, 0, -13.
- Muizon, C.d. (1988) Les relations phylogenetiques des Delphinida (Cetacea, mammalia). *Annales de Paléontologie*, 74, 159-227.
- Natoli, A., Peddemors, V.M. & Hoelzel, A.R. (2004) Population structure and speciation in the genus *Tursiops* based on microsatellite and mitochondrial DNA analyses. *Journal of Evolutionary Biology*, 17, 363-375.
- Natoli, A., Cañadas, A., Peddemors, V.M., Aguilar, A., Vaquero, C., Fernández-Piqueras, P. & Hoelzel, A.R. (2006) Phylogeography and alpha taxonomy of the common dolphin (*Delphinus* sp.). *Journal of Evolutionary Biology*, 19, 943-954.
- Norris, R.D. (2000) Pelagic species diversity, biogeography, and evolution. *Paleobiology*, 26, 236-258.
- Olson, D.B., Podestá, G.P., Evans, R.H. & Brown, O.B. (1988) Temporal variations in the separation of Brazil and Malvinas Currents. *Deep Sea Research Part A. Oceanographic Research Papers*, 35, 1971-1990.
- Perrin, W. (1989) Dolphins, porpoises, and whales. *An action plan for the conservation of biological diversity: 1988-199*. IUCN, Gland, Switzerland.
- Perrin, W. (1990) Subspecies of *Stenella longirostris* (Mammalia: Cetacea: Delphinidae). *Proceedings of the Biological Society of Washington*, 103, 453-463.
- Perrin, W. (2002) Common dolphins *Delphinus delphis*, *D. capensis*, and *D. tropicalis*. *Encyclopedia of marine mammals*, 245-248.
- Perrin, W. & Best, P. (2007) The south african species gate. In. Cambridge University Press Cape Town.
- Perrin, W., Mitchell, E., Mead, J., Caldwell, D. & Van Bree, P. (1981) *Stenella clymene*, a rediscovered tropical dolphin of the Atlantic. *Journal of Mammalogy*, 583-598.
- Perrin, W.F. (1975) Variation os spotted and spinner porpoise (genus *Stenella*) in the Eastern Pacific and Hawaii. *Bulletin of the Scripps Institution of Oceanography of the University of California*, 21.
- Perrin, W.F., Würsig, B. & Thewissen, J.G.M. (2009) *Encyclopedia of Marine Mammals*, 2 edn. Academic Press, San Diego.
- Perrin, W.F., Rosel, P.E. & Cipriano, F. (2013) How to contend with paraphyly in the taxonomy of the delphinine cetaceans? *Marine Mammal Science*, 29, 567-588.
- Perrin, W.F., Robertson, K.M., Van Bree, P.J. & Mead, J.G. (2007) Cranial description and genetic identity of the holotype specimen of *Tursiops aduncus* (Ehrenberg, 1832). *Marine Mammal Science*, 23, 343-357.
- Perrin, W.F., Mitchell, E.D., Mead, J., Caldwell, D.K., Caldwell, M.C., van Bree, P.J.H. & Dawbin, W.H. (1987) Revision of the spotted dolphins, *Stenella* spp. *Marine Mammal Science*, 3, 99-170.
- Pichler, F.B., Robineau, D., Goodall, R.N.P., Mejer, M.A., Olivarría, C. & Baker, C.S. (2001) Origin and radiation of Southern Hemisphere coastal dolphins (genus *Cephalorhynchus*). *Molecular Ecology*, 10, 2215-2223.
- Quérrouil, S., Freitas, L., Cascão, I., Alves, F., Dinis, A., Almeida, J.R., Prieto, R., Borràs, S., Matos, J.A. & Mendonça, D. (2010) Molecular insight into the population structure of common and spotted dolphins inhabiting the pelagic waters of the Northeast Atlantic. *Marine Biology*, 157, 2567-2580.
- Romero, A., Agudo, A.I., Green, S.M. & di Sciara, G.N. (2001) Cetaceans of Venezuela: their distribution and conservation status.
- Seeliger, U., Odebrecht, C. & Castello, J.P. (1997) *Subtropical Convergence Environments - The Coast and Sea in the Southwestern Atlantic*. Springer-Verlag Berlin.

- Shannon, L., Boyd, A., Brundrit, G. & Taunton-Clark, J. (1986) On the existence of an El Niño-type phenomenon in the Benguela system. *Journal of marine Research*, 44, 495-520.
- Slater, G.J., Price, S.A., Santini, F. & Alfaro, M.E. (2010) Diversity versus disparity and the radiation of modern cetaceans. *Proceedings of the Royal Society B: Biological Sciences*, 277, 3097-3104.
- Spalding, M.D., Agostini, V.N., Rice, J. & Grant, S.M. (2012) Pelagic provinces of the world: A biogeographic classification of the world's surface pelagic waters. *Ocean & Coastal Management*, 60, 19-30.
- Steehan, M.E., Hebsgaard, M.B., Fordyce, R.E., Ho, S.Y.W., Rabosky, D.L., Nielsen, R., Rahbek, C., Glenner, H., Sørensen, M.V. & Willerslev, E. (2009) Radiation of Extant Cetaceans Driven by Restructuring of the Oceans. *Systematic Biology*, 58, 573-585.
- Stramma, L. & Peterson, R.G. (1990) The South Atlantic Current. *Journal of Physical Oceanography*, 20, 846-859.
- Summerhayes, C., Kroon, D., Rosell-Melé, A., Jordan, R., Schrader, H., Hearn, R., Villanueva, J., Grimalt, J. & Eglinton, G. (1995) Variability in the Benguela Current upwelling system over the past 70,000 years. *Progress in Oceanography*, 35, 207-251.
- Teixeira, R.A., Campos, L.A. & Lise, A.A. (2014) Phylogeny of Aphantochilinae and Strophinae *sensu* Simon (Araneae; Thomisidae). *Zoologica Scripta*, 43, 65-78.
- Teske, P.R., Papadopoulos, I., Barker, N.P., McQuaid, C.D. & Beheregaray, L.B. (2014) Mitonuclear discordance in genetic structure across the Atlantic/Indian Ocean biogeographical transition zone. *Journal of Biogeography*, 41, 392-401.
- Tezanos-Pinto, G., Baker, C.S., Russell, K., Martien, K., Baird, R.W., Hutt, A., Stone, G., Mignucci-Giannoni, A.A., Caballero, S., Endo, T., Lavery, S., Oremus, M., Olavarría, C. & Garrigue, C. (2009) A Worldwide Perspective on the Population Structure and Genetic Diversity of Bottlenose Dolphins (*Tursiops truncatus*) in New Zealand. *Journal of Heredity*, 100, 11-24.
- True, F.W. (1889) *Contributions to the natural history of the cetaceans: A review of the family Delphinidae*. US Government Printing Office.
- Van Waerebeek, K., Barnett, L., Camara, A., Cham, A., Mamadou, D., Djiba, A., Jallow, A., Ndiaye, E., Bilal, A. & Bamy, I. (2004) Distribution, Status, and Biology of the Atlantic Humpback Dolphin, *Sousa teuszii* (Kükenthal, 1892). *Aquatic Mammals*, 30, 56-83.
- Vilstrup, J., Ho, S., Foote, A., Morin, P., Kreb, D., Krutzen, M., Parra, G., Robertson, K., de Stephanis, R., Verborgh, P., Willerslev, E., Orlando, L. & Gilbert, M.T. (2011) Mitogenomic phylogenetic analyses of the Delphinidae with an emphasis on the Globicephalinae. *BMC Evolutionary Biology*, 11, 65.
- Voris, H.K. (2000) Maps of Pleistocene sea levels in Southeast Asia: shorelines, river systems and time durations. *Journal of Biogeography*, 27, 1153-1167.
- Whitmore Jr, F.C. (1994) Neogene climatic change and the emergence of the modern whale fauna of the North Atlantic Ocean. *Proceedings of the San Diego Society of Natural History* (ed by, pp. 223-227.

CONSIDERAÇÕES FINAIS

O objetivo geral que guiou este trabalho foi a busca por padrões espaciais entre os taxa pertencentes à família Delphininae, a fim de identificar processos envolvidos na evolução do clado. Os principais desafios a este estudo foram a falta de resolução taxonômica, as diferenças entre as hipóteses filogenéticas geradas com dados moleculares e morfológicos propostas para o clado e a dificuldade de se reconhecer barreiras em uma ambiente aparentemente contínuo, como o ambiente marinho.

A Análise Espacial de Vicariância conduzida em duas propostas filogenéticas diferentes para o clado Delphininae revelaram congruência nos eventos que levaram a disjunção de táxons irmãos. Estes dados sugerem que apesar da aparente continuidade dos oceanos e da alta capacidade de dispersão dos cetáceos, a especiação alopátrica parece ter tido grande influência na diversificação de linhagens no clado Delphininae.

O Istmo no Panamá parece ter sido uma importante barreira que levou a divergência das linhagens na base do clado Delphininae. A corrente de Benguela parece ter tido grande influência na separação das espécies, pois a impermeabilidade da barreira durante períodos mais frios pode ter isolado populações em diferentes bacias oceânicas levando a especiação alopátrica. Enquanto que a variação do nível do mar ao longo dos ciclos glaciais- interglaciais durante o Pleistoceno parece ter levado a fragmentação de populações costeiras, promovendo a formação de “ecótipos” restritos a nichos locais.

Esforços devem ser direcionados para a realização de estudos que contemplem, concomitantemente, aspectos genéticos, morfológicos e ecológicos, além de amostragens completas da distribuição dos táxons, visando refinar a taxonomia do clado. Desta forma, será possível ter um melhor entendimento das relações filogenéticas entre as diferentes linhagens de Delphininae, bem como dos processos geradores de diversidade nos oceanos.

ANEXO 1 (APPENDIX 1)

<i>Delphinus sp.</i>		
Reference	Latitude	Longitude
	41.63	41.62
	44.47	34.16
	44.71	37.78
	9	-84.16
	8.41	-84
	9.3	-84.76
	8.13	-87.9
	7.53	-83.9
	7.4	-84.03
	8.23	-83.25
	7.75	-90.83
	8.66	-84.53
	44.38	-63.68
	43.53	-64.41
	42.96	-63.71
	40.18	-73.55
	39.65	-71.9
	39.33	-72.73
(Perrin, 1994)	39	-73.58
	38.8	-73.08
	38.9	-73.01
	38.93	-72.88
	38.63	-73.23
	38.58	-73.28
	38.23	-73.73
	38.18	-73.76
	37.95	-74.65
	37.78	-74.86
	37.73	-74.73
	37.45	-74.46
	37.3	-75.01
	42.38	-70.91
	40.55	-74.03
	39.86	-74.00
	35.49	-75.40
	37.19	-76.21
	26.89	-83.38
	46.91	-27.85
(Lucas & Hooker, 1997)	44	-60
(Bearzi <i>et al.</i> , 1998)	44.58	14.5
(Siciliano, 1994)	22.93333333	-43.25
	-22.93	-43.25
	25.01	-47.91
(Geise & Borobia, 1987)	-23.01	-43.36
	-27.57	-48.42

(Simões-Lopes & Ximenez, 1993)	-27.71	-48.49
	-27.43	-48.38
	-27.46	-48.37
	-26.89	-48.64
	-26.78	-48.60
(Das <i>et al.</i> , 2000)	50	-20
(Bearzi, 2000)	38.63	-20.97
(Forcada <i>et al.</i> , 1995)	42	8
	-34.96	173.6
	31	-120.13
	38.58	-126.21
	31.21	-120.13
	35.65	-124.98
	35.36	-123.15
(Perrin <i>et al.</i> , 1995)	36.3	-124.76
	36.98	-126.11
	37.13	-125.71
	37.16	-127.9
	37.68	-127.7
	35.7	-122.66
	47	-2.01
(Ohizumi <i>et al.</i> , 1998)	40	150
	10.73	-63.15
	10.9	-63.63
	10.96	-63.81
	11.08	-63.98
	10.9	-64.1
	10.91	-65.15
	10.91	-64.1
	11	-64.1
	10.5	-64.16
	10.96	-64.16
	10.48	-64.16
(Romero <i>et al.</i> , 2001)	11.05	-64.2
	10.45	-64.21
	10.66	-64.33
	10.45	-64.36
	10.36	-64.36
	11.03	-64.4
	10.41	-64.43
	10.4	-64.46
	10.21	-64.51
	10.26	64.63
	10.9	-65.08
	10.58	-66.05
	10.63	-66.56
	34.41	-119.68
(Fertl <i>et al.</i> , 1999)	33.57	-117.86
	32.89	-118.52
	32.85	-117.27

	-41.04	173.29		-33.56	-51.9
	-41.08	174.30		-24.31	-47
	-35.16	174.32		-31.3	-50.96
	36.10	-5.34		-24.12	-46.31
	-41.01	174.09		-23.14	-44.14
	36.76	-2.42		-23.06	-43.78
(Cañadas <i>et al.</i> , 2002)	30	-114		-26.56	-48.66
				-23.5	-44.73
(Silber <i>et al.</i> , 1994)	48.78	-3.23		-25.23	-48.02
(Breese & Tershy, 1993)	39	-9		-30,617	-48.36
				-32.48	-50.15
(Di Benedetto & Ramos, 2001)	-32.19	-52.17		-33.41	-50.82
(Silva, 1999)	-29.32	-49.71		-22.03	-41.05
	-25.04	-47.96		-24.86	-47.72
	-34.48	-52.01		-34.16	-51.3
	-29.36	-48.93		-33.35	-50.71
	-30.65	-48.95		-32.06	-50.08
	-33.68	-50.78		-32.08	-50,135
	-34.4	-51.88		-29.96	-50.11
	-31.16	-49.86		-33.09	-49.99
	-23.01	-43.41		-29.34	-47.63
	-34.51	52.1		-30.61	-48.56
	-34.2	-51.38		-32.32	-50.12
	-33.83	-51.3		-24.86	-47.72
	-33.53	-50.96		-25.58	-48.38
	-32.18	-50.08		-22.72	-41.2
	-32.15	-52.1		-33.85	-51.62
	-23.01	-43.29		-22.93	-42.49
	-25.58	-48.38		-26.11	-48.61
	-27.71	-48.5		-25.38	-48.17
	-27.42	-48.41		-26.17	-48.53
(Tavares <i>et al.</i> , 2010)	-27.58	-48.42		-25.38	-48.19
	-25.23	-48.02		-25.1	-47.91
	-27.45	-48.37		-24.01	-46.42
	-26.9	-48.65		-22.99	-42.02
	-24.86	-47.72		-23	-42.01
	-22.22	-41.52		-22.96	-42.03
	-25.39	-48.18		-22.96	-42.78
	-25.23	-48.02		-31.19	-49.55
	-26.79	-48.62		-30.48	-48.16
	-23.21	-44.16		-30.19	-48.67
	-23.3	-44.5		-26.6	-48.68
	-42.33	-62		-34.54	-51.88
	-30.4	-50.3		-34.17	-51.6
	-25.54	-48.3		-33.48	-51.29
	-30.93	-49.18		-33.49	-50.71
	-32.9	-49.81		-26.31	-48.54
	-25.58	-48.38		-30.68	-49.2
	-23.16	-44.35		-30.91	-48.78
	-29.72	-49.99		-31.35	-49.67
	-22.99	-42.02		-22.18	-46.26
				-22.94	-42.3
				-34.23	-51.54
				-24.19	-46.81

	-26.43	-48.57		-34.18	18.43
	-29.2	-47.75		-34.23	18.38
	-23.01	-43.29		-33.68	18.43
	-22.97	-43.18		-34.45	19.31
	-35.03	-51.21		-34.55	20.41
	-32.71	-52.44		-34.3	18.4
	-30.22	-50.22		-34.63	24.63
	-22.93	-42.49		-33.83	25.93
	-22.73	-41.67		-34.25	24.88
	-22.78	-41.6		-34.2	18.3
	-22.86	-42.72		-34.73	19.06
	-22.89	-42.02		-34.81	20.48
	-30.15	-50.19		-34.46	20.5
	-30.83	-50.57		-17.71	11.45
	-31.02	-50.71		-34.31	18.46
	-30.92	-50.63		-34.15	18.43
	-23.03	-42		-34.46	20.96
	-23.01	-42		-34.23	18.31
	-23.02	-42.01		-34.45	18.48
	-31.21	-50.86		-34.15	18.86
	-24.06	-45.64		-34.8	19.18
	-22.94	-42.3		-34.9	19.51
	-1.74	-43.67		-35	19.96
	-1.73	-43.8		-34.73	19.06
	-0.61	-47.53		-34.65	18.98
	-22.83	-41.99		-34.08	18.56
	-23.13	-44.15		-34.43	19.23
	-34.4	-53.77		-34.68	20.25
(Robineau & Vely, 1998)	18.03	-16.15		-34.58	19.08
	-33.44	151.71		-34.11	22.51
(Eyre, 1995)	12.25	49.37		-34	25.13
(Peddemors, 1999)	-31.73	29.41		-34.45	21.56
	-33.78	-80.82		-34.1	18.51
	-29.5	-71.36		-34.13	18.33
(Cárdenas <i>et al.</i> , 1991)	-27.26	-75.5		-34.75	19.61
	-22.10	-70.22		-34.58	19.25
	-33.23	-73.76		-33.66	18.41
	51.52	-8.96		-34.1	18.46
	52.08	-10.53		-34.13	18.43
	45.83	-15.91		-34.33	18.45
	52.75	-10.15		-34.11	18.83
	53.01	-11.28		-5.73	-80.86
	51.05	-15.61			
(Berrow & Rogan, 1998)	51.05	-15.63			
	49.05	-13.25	(Van Waerebeek <i>et al.</i> , 1998)	35.93	-5.64
	48.96	-12.8		32.79	-9.01
	48.85	-13.8		32.82	-16.99
	50.93	-8.58		28.44	-16.65
	50.8	-8.96		24.20	-15.50
	52.56	-9.93	(Jefferson <i>et al.</i> , 1997)	18.15	-16.33
	-34.36	18.81		14.58	-17.33
(Sekiguchi <i>et al.</i> , 1992)	-33.91	18.4		15.16	-23.53
	-34.63	20.55		9.35	-13.48
	-34.11	18.46		8.02	-12.96

	5.03	-4.92
	-1.90	9.21
	-11.52	13.70
	5.87	-10.09
	4.12	8.91
	-12.46	-76.79
(Read <i>et al.</i> , 1988)	-11.72	-77.18
	-7.39	-79.57
	-9.08	-78.59
	-12.11	-77.08
	-29.86	31.04
(Cockcroft, 1992)	-0.76	-90.68
(Denkinger <i>et al.</i> , 2013)	4.8	-1.95
	4.85	-2.22
(Van Waerebeek <i>et al.</i> , 2009)	-33.96	18.34
	-3.42	10.64
	-22.94	14.49
	-18.0	11.29
	-36.68	175.18
	-36.61	174.81
	-36.51	175.05
	-36.58	174.95
	-35.51	174.71
	-36.65	175.1
(Stockin & Visser, 2005)	-36.21	175.16
	-36.85	174.81
	-36.21	175.2
	-35.11	174.33
	-36.43	175.03
	-34.96	173.95
	-34.96	173.6
	5.21	-3.98
	-22.67	-5.49
	-10.83	13.25
	-1.83	9.08
	-4.77	11.83
(Weir, 2010)	10	13.08
	-10.72	13.75
	6.16	2.35
	-0.74	8.82
	-11.8	11.7
(Selzer & Payne, 1988)	41.21	-67.38

<i>Lagenodelphis hosei</i>		
Reference	Latitude	Longitude
(McColl & Obendorf, 1982)	-38.16	144.33
(Watkins <i>et al.</i> , 1994)	13.23	-61.27

	15.61	-61.5
	15.21	-61.5
(Caldwell <i>et al.</i> , 1976)	16.15	-45.36
	22.61	120.28
	5.00	-95.75
	-30.78	30.96
	-30.15	32.33
	-30.16	153.16
	-29.55	32.2
	5.00	-122.36
(Miyazaki & Wada, 1978)	35.10	140.1
	23.25	138.45
	1.55	142.06
	0.00	-165
	23.25	138.45
	1.55	142.06
	3.00	141.91
	1.71	164.88
	24.58	-82.1
(Hersh & Odell, 1986)	-31.63	153.02
	-4.45	-171.23
	-25.25	153.25
	33.60	135.93
(Amano <i>et al.</i> , 1996)	35.10	140.11
	26.22	127.66
(Robison & Craddock, 1983)	5.00	122.36
(Van Bree <i>et al.</i> , 1986)	48.78	-3.23
(Dolar <i>et al.</i> , 1999)	9.04	123.03
(Bones <i>et al.</i> , 1998)	57.24	-7.43
	9.63	123.19
	9.59	124.36
	33.59	135.94
	30.77	130.29
	23.91	120.09
(Perrin <i>et al.</i> , 2003)	1.58	142.06
	-8.58	123.41
	-3.68	128.15
	-19.71	148.46
	-38.60	144.77
	-33.96	18.34
	-29.86	31.04
(Dolar <i>et al.</i> , 1997)	7.76	118.53
(Fraser, 1956)	1.60	110.99

	5.00	-95.75
	5.00	-122.36
(Perrin, 1973)	-30.78	30.96
	-30.15	32.33
	-29.55	32.2
	-30.16	153.16
(Azevedo <i>et al.</i> , 2003)	22.50	-41.84
(Di Benedetto & Ramos, 2001)	21.58	-40.98
	48.78	-3.23
	22.61	120.28
	5.00	-95.75
	-30.78	30.96
	-30.15	32.33
	-30.16	153.16
	-29.55	32.2
	5.00	-122.36
	35.10	140.1
	13.25	-61.2
	-30.08	32.1
	10.50	124.5
	23.25	138.45
	1.55	142.06
	25.00	153
(Van Bree <i>et al.</i> , 1986)	-27.50	32.66
	-32.50	28.5
	-33.66	26.66
	-38.16	144.33
	24.58	-82.1
	2.00	119
	48.78	-3.23
	0.00	-165
	-30.58	31.63
	-30.28	31.65
	-31.21	31.45
	-30.08	32.1
	-33.76	27.65
	23.25	138.45
	3.00	141.91
	1.71	164.88
	5.65	-122.35
	0.51	-96.98
(Moreno <i>et al.</i> , 2003)	-30.16	-50.2
	-31.17	-50.82
	-31.28	-50.94

	-31.35	-51.04
	-31.37	-51.05
	-31.07	-50.74
	-30.95	-50.66
	-30.96	-50.66
	-34.80	-55.85
	-34.81	-54.61
	-34.86	-55.26
	-34.43	-57.25
	-31.03	-50.71
	-33.11	-52.63
	-22.95	-42.01
	-22.85	-43.16
	-22.93	-42.31
	-31.83	-51.7
	-31.93	-51.86
	-3.68	-38.61
	-42.90	-65
	-24.00	-46.26
	-34.43	-57.43
	-34.81	-57.96
	-35.06	-57.51
	-34.78	-56.35
(Sekiguchi <i>et al.</i> , 1992)	-30.78	30.96
	-29.55	32.2
	4.16	73.51
(Anderson <i>et al.</i> , 1999)	28.44	-16.65
(Jefferson <i>et al.</i> , 1997)	8.51	120.89
(Dolar <i>et al.</i> , 2003)	-0.76	-90.68
(Denkinger <i>et al.</i> , 2013)	-0.26	8.62
(Weir <i>et al.</i> , 2013)	16.55	-24.46
(Torda <i>et al.</i> , 2010)	15.98	-22.78
	13.83	-16.76
(Van Waerebeek <i>et al.</i> , 2009)	27.8	-16.6
	47.7	-3.2
	47.9	-4.1
	57.24	-7.44
(Gomes-Pereira <i>et al.</i> , 2013)	13.83	-16.76
	4.79	-1.94
	4.86	-2.24
	16.58	-24.31
	15.98	-22.77

38.59	-28.04
32.65	-16.16
34.97	-76.05
25.92	-77.33
36.01	-73.51
25.97	-77.46
35.56	-74.6
13.17	-61.23
15.61	-61
15.21	-61
17.96	-66.06
17.96	-66.1
16.23	-60.9
10.48	-68.11
14.3	-61
12	-60
15.88	-61.3
16.45	-62
12.15	-68.27
14.76	-61.25
24.84	-82.1
25.48	-96.2
26.46	-91.02
28.08	-82.8
27.89	-90.4
27.63	-94.41
26.78	-93.06
26.4	-82.88
27.43	-97.28
27.32	-82.57
29.2	-86.24
25.99	-91.97
38.38	-28.33
38.31	-28.18
32.63	-16.84
33.31	126.83
(Kim <i>et al.</i> , 2013)	4.86 -2.25
	4.8 -1.95
(Weir, 2010)	3.16 6.78
	-7.63 11.34
	-7.66 -11.68

<i>Leucopleurus acutus</i>		
Reference	Latitude	Longitude
(Lucas & Hooker, 1997)	44	-60
(Fertl <i>et al.</i> , 1999)	42.99	-70.05
(Berrow & Rogan, 1998)	54.98	-8.56
(Jefferson <i>et al.</i> , 1997)	35.93	-5.64
	44.87	-67.15
	41.92	-70.03
(Rogan <i>et al.</i> , 1997)	52.12	-10.35
	52.26	-10.15
	54.55	-9.45
	52.23	-10.18
	43.60	-70.14
	54.00	-3.98
	58.41	6.05
	63.72	-16.67
(Weinrich <i>et al.</i> , 2001)	70.23	-21.97
	68.22	-54.03
	42.25	-70.24
	42.99	-70.05
	41.03	-68.96
	41	-69
	41.21	-67.38
	48	-3
	44.2	-18.38
(Cipriano, 2009)	45.21	-62.7
	49	-56
	54	-4
	69	0
	59.65	-43.91
	66.22	-15.47

<i>Sotalia fluviatilis</i>		
Reference	Latitude	Longitude
	8.6	-60.9
	8.83	-61.55
	10.1	-62.63
	8.36	-62.6
	10.4	-62.88
(Romero <i>et al.</i> , 2001)	10.45	-64.16
	8.06	-64.4
	3.16	-65.53
	7.16	-66.25
	11.46	-69.58
	10.58	-71.58

10	-71.66
11.66	-71.66
9.25	-71.75
9.5	-71.83
9.5	-71.91
9.5	-72
9.06	-72.28

<i>Sotalia guianensis</i>		
Reference	Latitude	Longitude
(Lucena <i>et al.</i> , 1998)	-6.77	-34.93
	-6.37	-35.00
	-7.17	-34.79
	-0.5	-47.46
	-0.61	-47.35
(Siciliano, 1994)	-1	-48.5
	-2.40	-44.41
	-2.51	-44
	-2.56	-42.74
	-3.50	-38.90
	-3.71	-38.54
	-7.11	-34.8
	-6.83	-35.11
	-8.05	-34.9
	-9.66	-35.71
	-10.35	-36.29
	-10.73	-36.85
	-10.99	-37.05
	-10.91	-37.04
	-27.43	-48.51
	-12.91	-38.58
	-12.90	-38.65
	-13.66	-38.91
	-17.33	-39.21
	-17.33	-39.25
	-17.33	-38.58
	-17.88	-39.36
	-18.41	-40.7
	-18.59	-39.73
	-18.42	-39.85
	-19.38	-39.81
	-20.21	-40.28
-21.37	-41.01	
-22.91	-42.81	
-22.93	-43.25	

-22.93	-43.06	
-22.96	-44.03	
-23.95	-46.33	
-24.33	-47.25	
-25.01	-47.91	
-25.51	-48.5	
-3.41	-39.03	
-3.62	-38.72	
-2.80	-40.51	
-3.54	-38.83	
-3.65	-38.68	
(Júnior <i>et al.</i> , 1999)	-3.05	-39.60
-3.20	-39.33	
-2.82	-40.22	
-27.49	-48.64	
-26.63	-48.67	
(Geise & Borobia, 1987)	-27.44	-48.53
-27.42	-48.46	
-27.59	-48.56	
(Simões-Lopes & Ximenez, 1993)	-27.55	-48.56

<i>Sousa chinensis</i>		
Reference	Latitude	Longitude
(Dolar <i>et al.</i> , 1997)	-0.30	108.79
(Jefferson & Van Waerebeek, 2004)	1.22	104.11
	13.08	100.44
	14.00	109.31
	22.34	114.07
	-27.20	153.25
	-26.44	153.10
(Frère <i>et al.</i> , 2008)	-26.98	153.16
	-23.36	150.83
	-28.00	153.43
	-19.25	146.82
(Peddemors, 1999)	22.34	114.07
	-27.33	153.19
	-23	151.02
	-23.15	150.94
-20.86	149.45	

<i>Sousa plumbea</i>		
Reference	Latitude	Longitude

	-34.28	22.99
	20.28	38.45
(Jefferson & Van Waerebeek, 2004)	19.77	57.87
	26.59	51.68
	25.12	66.62
	8.03	77.72
(Silber & Fertl, 1995)	-21.98	35.41
(Cockcroft, 1992)	-29.86	31.04

<i>Stenella attenuata</i>		
Reference	Latitude	Longitude
(Watkins <i>et al.</i> , 1994)	15.62	-61.50
	42.40	-70.98
	41.35	-71.63
	34.03	-77.88
	30.67	-81.42
	29.02	-80.88
	27.83	-80.43
	28.41	-80.61
	26.11	-80.10
	25.59	-80.16
	25.71	-80.24
	30.40	-87.20
	30.08	-84.21
	13.33	-61.23
	-3.84	-32.39
	11.00	-47.00
	9.00	-33.00
(Perrin <i>et al.</i> , 1987)	6.77	-24.58
	2.73	-29.00
	-15.92	-5.72
	15.16	-23.53
	-1.90	9.21
	20.28	38.45
	26.59	51.68
	-4.66	55.53
	-4.81	53.33
	-7.01	52.73
	-9.22	51.02
	-12.16	44.39
	-19.70	49.11
	-28.33	60.00
	11.57	42.71
	-9.58	160.73
	23.22	-106.43
	20.43	106.53

	18.30	-103.83
	16.27	-98.87
	11.73	-132.43
	9.65	-106.28
	9.45	-109.73
	9.00	-101.95
	8.95	-102.08
	8.70	-105.33
	8.48	-140.80
	8.30	-138.17
	8.28	-138.55
	8.27	-140.77
	8.25	-132.33
	8.22	-98.53
	8.22	-135.33
	7.50	-130.97
	7.30	-132.95
	5.90	-129.67
	4.92	-107.75
	4.67	-105.25
	2.92	-119.33
	-2.88	-98.75
	-6.03	85.77
	-8.80	-89.35
	-8.88	-90.78
	-9.05	-84.47
	-9.13	-90.57
	-9.20	-91.55
	-12.20	-83.28
	26.92	-80.08
	23.00	-84.47
	20.23	-84.58
	20.10	-84.48
	18.87	-74.83
	18.72	-74.70
	14.18	-61.00
	13.20	-61.45
	12.12	-61.75
(Cremer & Simões-Lopes, 1997)	-25.54	-47.83
(Baird <i>et al.</i> , 2001)	20.7	156.7
(Lucena <i>et al.</i> , 1998)	-5.87	-35.17
(Jefferson & Baumgardner, 1997)	29.20	-94.92
	27.39	-97.29
	27.83	-97.46
(Gilpatrick, 1987)	24.02	-166.67

25.00	-167.00
21.63	-160.42
-40.88	174.98
-9.00	161.00
4.98	172.08
-7.32	-169.97
-1.00	168.20
1.25	171.32
0.33	172.18
-2.80	172.97
-7.87	162.65
-16.00	168.00
-2.00	162.42
5.17	163.22
3.53	166.05
4.92	179.20
4.50	167.00
4.00	174.00
7.00	170.83
-8.33	160.00
-8.15	160.07
12.00	162.00
31.90	162.30
31.53	162.70
31.50	161.67
25.00	167.00
31.98	162.30
-14.07	170.13
3.00	-164.50
10.50	-166.58
13.00	-174.00
-35.00	180.00
-2.78	-174.22
40.75	173.00
-15.37	172.70
-1.27	174.20
1.90	161.43
-8.00	161.50
8.42	160.75
7.05	101.00
-12.33	126.52
10.50	124.00
-2.05	151.75
-2.15	151.17
-2.00	151.27
-2.43	151.57

0.00	143.87
-3.05	145.25
3.05	140.63
-4.22	146.45
-4.55	146.70
-4.72	147.00
-5.35	147.32
-1.32	151.38
-2.12	145.92
-0.52	144.07
-1.83	143.88
-2.08	144.83
-3.00	148.13
-2.97	148.68
1.30	145.47
6.18	150.73
-15.00	125.00
6.32	159.07
-4.33	152.42
-4.47	152.42
-1.53	140.68
-1.05	153.50
-1.05	154.52
-3.87	146.72
0.47	135.15
-0.57	139.38
2.73	152.18
4.80	149.90
-4.93	146.48
-1.28	144.32
-1.95	144.32
-3.80	125.72
-8.17	125.17
4.10	144.95
4.43	144.63
6.22	142.17
-2.67	154.60
-0.25	150.83
-0.42	152.08
-0.47	152.18
14.83	138.47
4.87	138.58
-1.15	157.82
-2.33	159.82
-6.62	159.58
-6.00	159.25

-4.33	155.85
-3.80	155.07
-3.42	153.73
-3.10	153.52
-1.82	151.88
-30.27	153.15
-6.00	126.00
3.00	104.00
10.00	100.00
5.23	131.05
2.93	149.40
4.45	149.90
-8.33	160.00
1.50	105.00
-6.00	126.00
2.00	102.50
-8.25	123.00
10.58	147.80
1.00	147.50
12.00	100.00
-8.43	123.20
27.42	158.33
5.17	131.08
5.02	131.18
0.62	137.73
0.50	139.18
0.03	140.45
-1.43	147.20
2.22	156.40
-5.02	156.03
-14.42	123.42
2.98	149.40
1.42	144.20
20.65	149.62
33.60	135.93
34.95	139.13
34.87	139.10
33.63	136.27
32.67	129.83
33.00	129.10
26.67	124.83
25.92	143.63
25.53	142.00
25.37	142.72
23.50	151.70
23.58	151.58

24.08	149.15
31.47	134.60
32.05	135.02
33.32	137.87
26.68	143.12
37.00	140.92
36.62	148.77
27.17	129.37
31.80	131.68
33.00	128.50
35.03	146.70
36.02	147.33
36.42	144.77
22.33	118.00
26.23	127.77
34.18	136.32
34.98	138.40
39.23	141.97
31.15	130.57
34.98	138.40
37.72	143.42
37.63	143.83
32.63	134.07
26.75	127.75
34.95	139.13
26.83	127.67
26.92	127.58
26.58	127.50
26.67	127.50
31.15	130.57
39.17	142.00
22.33	118.00
34.00	138.00
14.50	89.00
10.20	75.57
8.05	75.57
22.00	90.00
3.00	58.00
3.50	72.50
6.00	77.00
-7.00	53.75
4.50	55.50
-9.23	51.03
-7.83	52.83
4.00	73.47
-4.25	55.75

4.50	55.50
8.02	79.75
6.97	79.72
9.63	81.00
9.60	81.13
8.00	79.75
8.02	79.72
6.35	79.67
6.12	79.83
8.13	82.13
8.57	81.65
8.63	81.50
8.58	81.42
9.17	81.20
8.90	81.22
9.45	80.97
9.17	81.12
8.50	81.42
9.00	81.00
8.50	81.50
6.00	80.50
9.40	80.98
5.55	80.55
8.67	81.33
26.07	34.25
28.33	60.00
12.40	44.55
-35.00	22.00
-30.07	31.45
-15.00	45.00
-21.70	55.42
-28.40	32.43
-28.00	30.33
-32.00	51.00
24.13	57.00
-20.72	50.80
-31.33	31.85
-34.10	57.12
-34.00	57.47
-32.52	66.90
-32.08	66.57
-31.07	58.83
-31.08	52.05
-30.98	40.15
-35.50	42.65
-32.57	30.47

	-30.05	31.12
	3.50	82.00
	14.25	92.50
	6.92	76.50
	6.93	79.48
	13.50	84.25
	14.00	89.50
	-3.25	40.13
	22.67	59.50
	11.58	43.18
	-31.45	30.23
	-20.72	50.80
	-15.00	45.00
(Kasuya, 1976)	34.93	139.14
	34.90	139.13
	33.59	135.94
(Dolar <i>et al.</i> , 1997)	5.00	-122.36
	-30.78	30.96
(Perrin <i>et al.</i> , 1985)	8.33	-78.75
	8.21	-78.78
	8.13	-78.83
	8.11	-78.83
	8.1	-78.83
(Eyre, 1995)	-12.33	91.09
	20.93	38.51
	22.53	37.54
(Peddemors, 1999)	-28.12	32.56
	-31.73	29.41
	13.24	-61.27
	11.33	-74.08
	10.36	-64.56
	18.86	-74.83
	18.71	-74.7
	10.18	-75.77
	14.18	-61
	13.2	-61.45
(Mignucci-Giannoni <i>et al.</i> , 2003)	15.53	-61.5
	15.56	-61.5
	15.55	-61.58
	14.5	-61.16
	14.43	-61.08
	14.76	-61.26
	14.64	-61.14
	15.6	-61.5
	15.41	-61.5
	15.45	-61.51

15.63	-61.5
23	-84.33
20.23	-84.58
20.1	-84.48
15.58	-61.51
15.51	-61.56
14.78	-61.21
15.56	-61.5
15	-61
15.41	-79.28
15.31	-61.43
15.54	-61.5
15.49	-61.48
15.46	-61.53
24.16	-71.23
14.66	-61.25
14.63	-61.25
13.2	-74.26
11.83	-78.08
10.08	-79.96
12.13	-69
16.33	-82.63
17.35	-85.33
17.53	-86.36
10.99	-64.04
15.51	-61.5
15.64	-61.51
15.53	-61.5
15.35	-61.42
15.2	-61.4
15.62	-61.5
15.63	-61.5
15.5	-61.5
15.38	-61.49
15.5	-61.56
15.51	-61.51
15.54	-61.52
15.53	-61.51
15.57	-61.51
15.57	-61.5
15.31	-61.45
17.38	-71.45
17.76	-74.63
17.76	-74.55
17.7	-74.13
20.11	-81.86

	15.52	-61.51
	15.62	-61.62
	12.01	-68.66
	12.05	-68.86
	13.85	-61.11
	13.91	-61.21
	11.19	-60.63
	16.05	-61.82
	16.31	-61.15
	16.08	-61.81
	13.93	-61.15
	12.08	-61.83
	10.65	-60.66
	14.98	-61.01
	15.29	-61.39
	10.66	-65.12
	18.01	-67.42
	19.24	-65.46
	17.87	-66.71
	17.63	-67.01
	10.33	-64.5
(Sekiguchi <i>et al.</i> , 1992)	-29.83	31
	-21.7	55.41
(Anderson <i>et al.</i> , 1999)		
	6.53	72.9
(Jefferson <i>et al.</i> , 1997)	5.03	-4.92
	5.45	-0.35
(Read <i>et al.</i> , 1988)	-12.46	-76.79
	-13.03	-76.48
(Borrell <i>et al.</i> , 2004)	7.25	-81.85
	7.88	-81.78
	7.5	-81.91
	7.53	-81.91
	7.58	-82.01
	7.41	-81.96
(Perrin, 1975)	12.85	93.3
	7.18	90.53
	10.51	92.86
	7.83	90.53
	9	92
	9.83	89.78
	10.6	102.03
	13.5	88
	2.5	86
	9.46	129.3
	9.33	110.73

	11	125
	10	135
	12	136
	9.78	133.41
	8.16	106.88
	7.78	100.83
	7	103
	18	107
	9	114
	10	118
	10	124
	11	128
	8	107
(Denkinger <i>et al.</i> , 2013)	-0.76	-90.68
(Van Waerebeek <i>et al.</i> , 2009)	5.28	-0.73
	0.25	8.73
(Weir, 2010)	4.18	0.75
	0.34	6.72
	-11.8	11.7
	-3.83	-32.42
	-16.55	-37.53
	-4.10	-36.67
	-5.83	-34.60
	-5.52	-34.82
	-5.42	-34.88
	-6.37	-34.58
	-7.00	-34.02
	-6.52	-34.18
	-6.43	-34.22
	-5.95	-34.13
	-5.93	-34.13
(Moreno <i>et al.</i> , 2005b)	-6.28	-33.75
	-6.25	-33.77
	-6.13	-33.55
	-8.40	-34.33
	-8.63	-34.53
	-5.50	-33.98
	-7.12	-33.70
	-7.12	-33.73
	-7.20	-34.00
	-6.77	-33.37
	-7.45	-33.92
	-9.68	-35.18
	-16.55	-37.53
	-16.45	-38.32

	-5.43	-34.18
	-5.60	-33.30
	-5.98	-33.20
	-6.18	-33.17
	-6.27	-33.55
	-6.67	-34.52
	-6.90	-34.05
	-7.18	-33.62
	-8.05	-34.38
	-8.12	-34.27
	-8.77	-33.10
	-15.68	-38.07
	-8.18	-34.20
	-8.30	-34.31
	-5.11	-33.58
	-5.42	-34.06
	-5.76	-34.42
	-17.22	-36.93
	-19.98	-39.58
	-21.83	-39.76
	-19.47	-35.26
This study	-20.55	-31.86

<i>Stenella attenuata graffmani</i>		
Reference	Latitude	Longitude
(Worthy <i>et al.</i> , 1993)	36.96	-121.95
	12.85	-93.3
(Perrin & Roberts, 1972)	7.18	-90.53
	7.78	-106.6
	7	-78.5
	3	-78.33
	27.93	-111.13
	21.86	-105.9
	21.16	-106.16
	16.23	-98.48
	17.53	-101.73
(Perrin, 1975)	9.95	-86.43
	9.83	-85.8
	21.35	-105.51
	22.96	-106.35
	16.25	-98.91
	9.88	-85.9
	7.96	-82.03
	16.96	-109.91

<i>Stenella clymene</i>		
Reference	Latitude	Longitude
	28.12	-96.03
(Jefferson, 1996a)	29.16	-91.61
	26.89	-83.38
(Fertl <i>et al.</i> , 1997)	39.86	-74
	27.2	-95.28
	24.54	-81.78
	27.21	-97.34
	29.23	-91.24
(Jefferson <i>et al.</i> , 1995)	27.64	-82.74
	27.44	-82.68
	27.34	-82.56
	24.72	-81.24
(Jefferson, 1996b)	29.7	-87
	20.85	-96.06
	39.27	-74.56
	29.89	-81.3
	27.34	-82.56
	27.77	-82.62
(Perrin <i>et al.</i> , 1981)	27.21	-97.34
	12.25	-61.6
	13.33	-61.23
	-3.66	-18.08
	4.3	-31.33
	14.58	-17.33
(Lucena <i>et al.</i> , 1998)	2.16	-2.5
	-7.11	-34.81
	-7.13	-34.81
(Jefferson & Baumgardner, 1997)	28.87	-95.32
	29.36	-94.86
	27.25	-97.57
	27.83	-97.46
	27.83	-97.04
	14	-16.77
	2.16	-2.5
(Robineau <i>et al.</i> , 1994)	16	-16.56
	14.77	-17.42
	14.91	-17.12
	12.73	-17.75
	19	-16.24
	-29.3	-49.7
(Soto <i>et al.</i> , 2000)	-3.21	-38.91
	-9.51	-35.58
	-12.5	-37.96

	-31.88	-50.2
	-27.41	-46.63
	-28.15	-48.38
(Romero <i>et al.</i> , 2001)	-26.7	-48.67
(Weir, 2006)	10.73	-63.15
	-6.43	11.41
	-4.38	10.53
	38	-74
	-2.16	-2.5
	28.88	-18.18
	29.36	-71.86
	30.8	-71.8
	26.15	-79.61
	27.01	-90.3
	26.13	-90.98
	26.53	-96.88
	27.68	-87.03
	28.55	-88.03
	27.53	-87
	26.61	-91.98
	27.86	-90.36
	27.56	-91.98
	35.43	-74.7
	27.36	-92.16
	25.96	-88.28
(Fertl <i>et al.</i> , 2003)	26.2	-91.01
	27.3	-93.01
	27.28	-93.5
	26.71	-90.03
	27.81	-89.98
	28.15	-88.98
	27.26	-95.06
	27.45	-93.61
	26.55	-94.26
	26.4	-93.63
	27.1	-91.83
	27.18	-91.78
	27.26	-91.73
	27.56	-92.31
	27.41	-89.86
	27.1	-88.96
	26.66	-91
	26.81	-93.96
	27.46	-92.16
	26.86	-92.81
	26.28	-94.38

26.26	-94.63
26.35	-93
27.78	-88.65
26.28	-94.2
27.03	-90
27.68	-91
27.45	-91
27.36	-90.93
26.71	-92
27.48	-89.16
28.43	-88.51
27.16	-93.11
27.58	-89.31
26	-87.98
27.36	-92.16
27.5	-91
26.85	-91.98
26.25	-93
27.31	-95.01
26.68	-87.98
26.93	-91
26.56	-91.96
28.5	-86.26
27.31	-85.31
27.41	-46.61
27.2	-95.28
26.1	-87.43
26.03	-95.15
28.3	-89.58
-28.86	-46.93
28.85	-87.3
28.85	-87.3
27.41	-93.31
34.31	-75.41
35.23	-74.38
35.58	-74.48
35.46	-73.5
35.73	-74.63
7.58	-33.83
-6.9	-33.81
-6.15	-33.53
27.21	-88.98
28.68	-88
27.5	-89.98
27.05	-89.01
26.76	-89.95

28.05	-89.71	
28.08	-89.45	
-7.2	-33.95	
-7.66	-33.41	
36.08	-73.75	
35.78	-74	
-7.43	-34.26	
-8.46	-33.48	
-10.26	-33.65	
-10.23	-33.76	
26.33	-91.98	
27.63	-89.41	
27.25	-87.98	
27.16	-89	
27.71	-90.03	
27.43	-91	
27.5	-91.4	
-8.5	-33.56	
-8.88	-34	
36.75	-73.11	
4.3	-31.33	
-3.66	-18.08	
16	-17.33	
27.75	-82.75	
12.41	-61.6	
13	-61	
13	-61	
13	-61	
13	-61	
(Ximenez & Praderi, 1992)	12.73	-17.75
(Robineau & Vely, 1998)	-3.66	-18.08
(Júnior <i>et al.</i> , 1999)	18.03	-16.15
(Simões-Lopes <i>et al.</i> , 1994)	-3.5	-38.9
	-29.3	-49.7
(Jefferson <i>et al.</i> , 1997)	18.15	-16.33
	14.58	-17.33
(Van Waerebeek <i>et al.</i> , 2009)	3.59	3.73
	5.91	0.98
	5.34	-0.6
	5.28	-0.73
	2.16	-2.5
(Weir, 2010)	5.33	-0.62
	-4.39	10.54
	-6.43	11.41

	-14.43	12.15
	-7.58	-33.83
	-6.9	-33.81
	-6.15	-33.53
	-7.2	-33.95
	-7.66	-33.41
(Moreno <i>et al.</i> , 2005b)	-7.43	-34.26
	-8.46	-33.48
	-10.26	-33.65
	-10.23	-33.76
	-8.5	-33.56
	-8.88	-33.16
	-27.41	-46.63
	-28.86	-46.93
This study	-14.79	-38.65

<i>Stenella coeruleoalba</i>		
Reference	Latitude	Longitude
(Lucas & Hooker, 1997)	44	-60
(Bearzi <i>et al.</i> , 1998)	44.58	14.5
	50.11	0.9
	50.62	-4.83
	51.06	-4.25
	44	-28.4
	42.38	-70.91
	40.55	-74.03
(Perrin <i>et al.</i> , 1981)	37.7	-73.56
	37.16	-74
	37.19	-76.21
	35.49	-75.4
	37.46	-72.15
	13.33	-61.23
	-35.19	-56.74
	-30.23	-50.23
	-29.46	-49.81
	-32	-51.66
(Ott & Danilewicz, 1996)	-6.96	-34.81
	-34.85	-54.61
	-34.81	-55.91
	-38.28	-57.83
	29.44	-94.63
(Jefferson & Baumgardner, 1997)	29.65	-93.85
	27.71	-97.17
(Brownell Jr. &	-34.84	-55.95

Praderi, 1975)	-34.92	-54.97
	25	145
	20	126
	21	128
	24	140
	30	150
(Kasuya, 1999)	35	135
	45	140
	42	150
	37	145
	37	180
	38	150
(Reynoso, 1985)	21.53	-105.31
(Odell & Chapman, 1976)	27.86	-83.41
	27.25	-80.35
(Blanco <i>et al.</i> , 1995)	40.41	-0.53
	37.58	0.75
(Das <i>et al.</i> , 2000)	46	-9
(Forcada <i>et al.</i> , 1995)	42	8
(Marsili & Focardi, 1996)	40.2	13.17
	37.79	18.83
(Marsili <i>et al.</i> , 1997)	41.73	17.32
(Tanabe <i>et al.</i> , 1988)	33.58	135.95
	38.58	-126.21
	35.65	-124.98
(Perrin <i>et al.</i> , 1995)	36.3	-124.76
	36.98	-126.11
	-37.68	-127.7
(Kasuya, 1976)	34.93	139.14
	21.27	-157.83
	9	-178
	10.68	-124.35
	22.18	-108.81
	21.98	-106.9
(Hubbs <i>et al.</i> , 1973)	22.2	-107.53
	22.3	-108.06
	22.16	-108.21
	22.16	-108.15
	10.25	-109.75
	9.6	-89.48
	11.23	-127.78
	10.71	-64.68
(Romero <i>et al.</i> , 2001)	11.66	-64.83
	12.91	-67
(Cañadas <i>et al.</i> , 2002)	36.76	-2.42

(Ximenez & Praderi, 1992)	-34.82	-55.91
	32.79	-9.01
(Robineau & Vely, 1998)	18.15	-16.33
	14.58	-17.33
	5.03	-4.92
	-12.63	108.76
(Eyre, 1995)	35.07	18.64
	35.7	15.67
	35.8	1.24
(Peddemors, 1999)	-33.36	18.15
(Cárdenas <i>et al.</i> , 1991)	-23.65	-70.48
(Berrow & Rogan, 1998)	51.06	-15.66
(Rosas <i>et al.</i> , 2002)	-25.05	-47.89
	50.05	-16.93
	50.38	-15.78
	51.05	-11.83
	50.33	-11.73
	50.33	-11.98
	50.03	-12.91
	51.89	-30.14
	51.67	-29.71
	51.65	-29.68
	50.62	-27.92
(Bloch <i>et al.</i> , 1996)	50.57	-27.84
	50.73	-28.05
	52.34	-24.92
	53.81	-22.83
	63.85	-16.56
	61.4	-6.73
	62.11	-7.03
	57.63	-3.63
	55.76	-6.16
	55.66	-7.25
	57.25	-6.16
	60.25	-1.5
(Maia-Nogueira <i>et al.</i> , 2001)	-12.56	-37.98
	-20.33	-36.3
	-34.46	26.88
	-34.15	18.43
(Sekiguchi <i>et al.</i> , 1992)	-34.36	18.85
	-34.23	18.36
	-34.36	21.43
	-33.38	18.18

	-34.15	18.86
	-33.9	18.45
	-33.8	18.45
	-34.4	21.21
	-34.58	20.36
	1.6	-79.06
	1.8	-78.8
	6.04	-77.37
	-1.93	-80.71
	-0.55	-80.41
	-2.18	-80.83
(Van Waerebeek <i>et al.</i> , 1998)	-2.25	-80.85
	-0.74	-90.31
	-0.76	-90.33
	-14.13	-76.21
	-5.73	-80.86
	-20.95	-72.17
	-33.61	-78.88
	34.55	18.04
	35.93	-5.64
	32.82	-16.99
(Jefferson <i>et al.</i> , 1997)	14.58	-17.33
	15.16	-23.53
	32.79	-9.01
	5.03	-4.92
	28.44	-16.65
	-37.11	-56.86
	-37.25	-56.96
(Bastida <i>et al.</i> , 2001)	-38.5	-57.83
	-39	-55.4
	-39.33	-58.16
	-42.33	-62
(Denkinger <i>et al.</i> , 2013)	-0.76	-90.68
(Stockin & Visser, 2005)	-36.43	-175.03
	4.96	-6.13
(Weir, 2010)	-9.25	12.25
	-13.98	12.05
	-11.8	11.7
	9.94	51
	1.95	73.46
(Ballance & Pitman, 1998)	-3.57	55.33
	5.97	81.08
	8.63	66.58
	18.05	60.83

-20.29 55.49

Stenella frontalis

Reference	Latitude	Longitude
	15	-18
	37.73	-25.67
	40.25	-29.08
	46.33	-38.73
	38.66	-49
	35.25	-74.55
	38.08	-70.16
	38.25	-71.28
	39.51	-69.61
	41.62	-70.34
	40.96	-72.14
	38.92	-74.9
	40.46	-74.17
	38.03	-75.18
	36.91	-76.08
	36.62	-75.88
	35.22	-75.53
	35.25	-75.52
	35.22	-75.63
	35.27	-75.54
(Perrin <i>et al.</i> , 1987)	35.54	-75.46
	35.95	-75.61
	35.89	-75.58
	35.35	-75.49
	35.11	-75.98
	34.46	-77.47
	32.77	-79.91
	32.98	-79.54
	32.21	-80.75
	31.47	-81.2
	29.89	-81.3
	29.85	-81.26
	29.76	-81.24
	29.02	-80.91
	23.38	-82.38
	27.47	-80.28
	27.16	-80.18
	25.75	-80.18
	25.98	-80.11
	24.91	-80.63
	24.79	-81.49
	27.77	-82.62

	29.66	-83.41
	30.38	-86.49
	30.4	-87.2
	26.74	-82.26
	29.74	-93.71
	27.83	-97.04
	27.21	-97.34
	26.84	-97.35
	18.33	-64.93
	18.48	-66.55
	17.7	-67.36
	19.7	-67.83
	14.56	-60.05
	13.15	-61.23
	11.03	-61.9
	10.95	-61.56
	10.86	-66.46
	10.68	-66
	9.5	-79
	10	-39
	-15.92	-5.72
	15.16	-23.53
	14.58	-17.33
	5.03	-4.92
	3.48	8.85
	9.5	-13.67
	-4.77	11.83
	40.61	-12
	38	-73
	37	-74
	35.58	-75.33
	35.28	-74.25
	34.81	-75.6
	34.75	-76.75
	32.83	-79.5
	24	-74.5
	25.18	-80.13
	24.33	-82.8
	18.71	-74.7
	17.5	-88
	17.05	-63.08
	14.5	-77.16
	12.5	-70
	12	-68
	11.65	-73.83
	11	-64

	24	-46
	38	-28
(Nieri <i>et al.</i> , 1999)	18.03	-16.15
(Herzing, 1997)	26.81	-78.56
(Jefferson <i>et al.</i> , 1995)	27.21	-97.34
(Lucena <i>et al.</i> , 1998)	-6.77	-34.93
	-6.68	-34.92
(Jefferson & Baumgardner, 1997)	29.54	-94.38
	-21.61	-41.01
(Siciliano, 1994)	-22.93	-43.25
	-23.16	-44.33
	-25.01	-47.91
(Herzing & Johnson, 1997)	27	-78
	-27.43	-48.38
(Simões-Lopes & Ximenez, 1993)	-27.59	-48.42
	-27.15	-48.57
	-28.42	-48.73
	10.95	-61.56
	11.03	-61.9
	11	-62.11
	11.41	-62.36
	10.73	-63.15
	11	-64
	11.05	-64.2
(Romero <i>et al.</i> , 2001)	10.25	-64.41
	10.95	-65.21
	10.15	-65.43
	10.6	-66.05
	10.86	-66.46
	10.68	-66
	11.46	-69.58
	10.98	-71.6
	11.66	-71.66
	28	-92
(Fulling <i>et al.</i> , 2003)	30	-86
	26	-83
(Fertl <i>et al.</i> , 1999)	38.39	-28.29
(Ximenez & Praderi, 1992)	-27.28	-48.36
(Alves-Júnior <i>et al.</i> , 1996)	-3.05	-39.60
	-3.14	-39.44
(MacLeod <i>et al.</i> , 2004)	28.44	-16.65

	9.35	-13.48
(Jefferson <i>et al.</i> , 1997)	5.03	-4.92
	-1.90	9.21
	3.59	3.73
(Danilewicz <i>et al.</i> , 2013)	-18.86	-38.41
(Van Waerebeek <i>et al.</i> , 2009)	4.8	-1.95
	6.16	2.35
(Weir, 2010)	-0.74	8.82
	-11.8	11.7
	-29.75	-49.36
	-25.26	-46
	-26.8	-47.18
	-23.05	-44.23
	-23.05	-44.11
	-23.05	-44.23
	-23.08	-44.21
	-23.23	-44.33
	-23.15	-41.67
	-23.16	-44.4
	-23.38	-42.13
	-23.23	-44.33
	-22.98	-42
	-22.66	-41.81
	-23.03	-43.25
	-27	-47.41
(Moreno <i>et al.</i> , 2005b)	-26.39	-47.35
	-25.76	-46.86
	-25.7	-46.81
	-25.36	-46.49
	-24.24	-45.52
	-23.43	-43.09
	-24.35	-44.5
	-24.36	-44.5
	-24.38	-45.71
	-24.13	-46.16
	-24.87	-45.1
	-24.86	-45.08
	-24.88	-45.03
	-26.08	-45.51
	-27.4	-47.2
	-27.62	-47.46
	-30.76	-48.8
	-30.77	-48.81

-26.35	-46.59
-24.1	-45.09
-27.56	-47.11
-22.3	-40.55
-25.83	-45.79
-25.64	-45.94
-29.84	-48.16
-24.27	-44.18
-24.86	-47.35
-23.18	-44.56
-23.65	-45
-23.15	-44.58
-24.8	-46.63
-24.7	-47.02

<i>Stenella longirostris</i>		
Reference	Latitude	Longitude
(Jefferson <i>et al.</i> , 1995)	24.54	-81.77
(Van Bree, 1971)	14.77	-17.42
	5.21	-3.98
(Secchi & Siciliano, 1995)	-23	-43
	-23.65	-44.13
	-25.58	-44.32
(Baird <i>et al.</i> , 2001)	20.7	-156.7
(Perrin <i>et al.</i> , 1981)	35.22	-75.53
	32.9	-79.58
	30.39	-81.43
	25.75	-80.18
	27.15	-82.48
	29.79	-84.6
	30.39	-86.61
	29.68	-93.89
	26.84	-97.35
	20.59	-77.81
	13.33	-61.23
	10.72	-66.5
	5.87	-10.09
	14.58	-17.33
(Perrin, 1990)	20.32	-156.02
	-10.5	105.67
	-15.1	-147.47
	-9.82	-139
	11.46	162.18
	34.52	138.08
	5.97	81.08
1.95	73.46	

5.03	-4.92	
(Lucena <i>et al.</i> , 1998)	-6.46	-34.97
(Jefferson & Baumgardner, 1997)	26.84	-97.35
	27.71	-97.17
	23.47	-166.4
	23.67	-166.5
	28.42	-178.17
	23.53	-166.43
	27.8	-175.85
	21.88	-160.07
	21.83	-160.18
	21.77	-160.12
	21.62	-160.28
	23.58	-164.7
	28.5	-178.17
	23.42	-166.33
	27.8	-175.85
	28.25	-177.42
	-0.87	166.7
	1.3	165.22
	-7.3	164.57
	-7.88	160.08
	-7.87	160.07
	1.38	-174.38
(Gilpatrick, 1987)	0.45	166.78
	1.97	169.58
	2.02	169.68
	1.93	160.72
	0.05	165.65
	36.83	170.98
	0.08	165.75
	-1.58	162.12
	27.68	163.6
	8	167
	11.5	162.25
-6.17	-175.5	
-5.92	-175.67	
-5.92	-175.83	
13	-174	
5.48	-162.07	
4.5	175.5	
-1.7	160.55	
16.38	162.22	
-7.5	177.25	
-2.8	172.97	
11.5	162.25	

-14.28	-170.73
-18.67	-174.08
-8.4	-170.03
2.07	176.87
-9	161
7.03	171.67
-9.35	159.98
-8.5	151.08
-8.4	157.35
-8.15	156.92
-4.08	152.08
-6.03	110.03
-19.22	146.8
-9.37	142.67
-27.2	153.1
-2.92	153.37
-3.8	155.3
-8.03	138.12
7.2	136.62
6.58	131.43
4.8	149.75
3.18	142.12
3.05	141.95
0.42	153.15
-5.17	156.57
-4.9	156.18
-2.15	157.75
-1.4	147.37
-6.57	158.13
-4.92	152.93
-6.52	157.43
-8.83	159.87
-7.68	159.92
0.25	125
0	125
-5	110
-5.38	106.22
2.3	101.87
-8.53	123.5
-12.63	126.4
-12.37	127.45
-5.23	145.67
-4.55	149.13
-12.32	127.47
-5.23	145.75
-12.38	127.4

-4.22	152.18
-12.4	127.33
-16.85	145.72
-7	108
-12.45	127.32
7.2	100.6
13.42	100.05
-8	124
-8.53	124
-2.47	151.47
-2.38	151.33
-2.07	151.25
-2.38	151.55
-1.95	148.58
1.3	145.47
-1.62	144.8
-2.38	148.4
-0.8	144.45
0.05	145.07
-2.77	147.58
-3.1	145.23
0.75	146.5
-1.97	142.82
-1.27	145.2
-0.82	144.5
6.22	142.17
4.1	144.02
2.87	141.12
2.87	143
4.53	138.65
4.03	142.03
4.12	139.52
4.37	142.22
5.85	150.57
7.38	135.2
5.58	135.07
4.67	135.58
4.57	136.3
4.47	136.68
6.65	154.13
7.12	137.27
1.55	144.98
7.72	144.2
-25.38	112
-15.03	122.18
-14.85	122.52

-14.28	123.6
-12.17	127.62
-5.92	156.88
-5.02	156.03
7.57	154.32
4.45	149.9
2.98	149.4
5.33	131.02
-8.6	151.37
3.77	98.77
4	104.5
10.28	123.93
2.15	122.27
-1.25	106.55
7.87	98.45
-16.58	146.03
-11.6	144.02
-12.05	143.22
9.33	153.58
6	150.83
3.33	152.92
-4.57	149.1
-22.28	155.38
31.72	152.83
32.75	129.87
28.75	129.75
33	128
32.73	129.83
32.78	129.83
11.48	79.77
10.88	75.2
10.38	75.5
16	73.33
11	75.62
-4.18	55.67
-4	55.43
4.5	73.15
4.47	73.42
5.52	74.12
4.17	73.52
3.98	73.28
5.83	73
6.87	73
-0.7	73.17
9	81
5.75	81.25

6.5	79.5
6.02	80.18
6	80
6.92	79.87
7.22	79.82
7.97	79
6.02	80.78
6.27	79.95
7.33	79.33
6.37	81.52
7.57	79.35
7.53	79.57
10.25	80
7.68	82.08
6	80
7.3	79.8
9.77	80.9
7.2	82.18
5.85	81.03
9.17	81.22
9.47	80.95
9.45	80.97
7	79.75
7	79.4
5.78	80.12
6.93	79.48
6	79.88
5.87	80.3
5.88	80.37
8.55	81.27
9.92	81.1
8.58	81.38
6.48	79.95
6.5	79.95
6.33	81.5
8.35	81.85
8.65	81.32
8.58	81.58
9.52	80.95
9.67	81.1
8.6	81.42
8.63	81.5
8.52	81.35
8.7	81.33
8.6	81.37
8.57	81.25

	8.4	81.33
	8.53	81.33
	8.55	81.33
	-6	85
	11.67	42.75
	11.67	43.67
	19.17	39.47
	24.92	34.72
	23	60.33
	13.5	72
	20.15	63.5
	23	61
	20.25	58.75
	22.57	59.62
	23.33	58.93
	24	57.17
	20.27	58.75
	22.5	60.5
	22.57	59.53
	-4.67	39.35
	13.58	51.83
	16.75	54.18
	18.67	57.78
	16.88	54.2
	-27.77	32.63
	-27.78	32.63
	-28.03	32.58
	-28.87	32
	-34.15	26.25
(Barreto & Lodi, 2000)	-3.25	-32.42
(Siciliano, 1994)	25.02	-47.92
(Robineau & Rose, 1983)	11.7	43.05
(Debrot, 1998)	12.2	-69.05
	11.98	-68.68
(Tanabe <i>et al.</i> , 1988)	-6.03	85.77
(Dolar <i>et al.</i> , 1999)	9.04	123.03
(Dolar <i>et al.</i> , 1997)	1.6	110.99
	5	-95.75
	10.73	-63.15
	10.43	-64.03
	11	-64.08
(Romero <i>et al.</i> , 2001)	10.46	-64.18
	10.5	-64.23
	10.35	-64.35
	10.31	-64.41

	10.26	-64.45
	10.21	-64.63
	10.26	-64.63
	10.63	-66.7
	11.96	-67.45
	12	-67.66
(Fertl <i>et al.</i> , 1999)	28.19	-177.37
	20.73	-156.94
	9.48	123.92
(Ximenez & Praderi, 1992)	-23.48	-45.06
	-8.38	-137.6
	-8.7	-139.33
(Perrin <i>et al.</i> , 1985)	-8.96	-140.15
	-8.95	-140.05
	-8.93	-140.01
	-8.91	-140.01
	-8.95	-140.1
	-10.95	142.87
	-11.44	122.98
	-11.6	122.45
	-12.19	118.07
	-11.41	58.58
	-3.62	49.62
	-3.44	49.21
(Eyre, 1995)	12.22	50.92
	12.25	50.5
	12.27	50.33
	13.19	43.17
	15.5	41.79
	18.64	39.92
	18.82	39.82
	24.73	36.21
	24.74	36.2
	-28.12	32.56
(Peddemors, 1999)	-29.85	31.04
	-19.16	35.84
	-21.64	35.43
	-23	-43
	-6.4	-34.5
	-23.41	-44.85
(Soto & Caseca-Santos, 1999)	1.83	-29.33
	-3.85	-33.81
	-25.58	-44.31
	-22.88	-42.01
	-23.46	-45.13

	-5.75	-33.43
	-2.16	-41.57
	-13	-38.45
	-30.04	-46.29
	-27.15	-48.57
(Anderson <i>et al.</i> , 1999)	-0.66	73.16
	-0.61	73.06
	-0.61	73.11
(Jefferson <i>et al.</i> , 1997)	15.16	-23.53
	18.15	-16.33
(Perrin & Roberts, 1972)	12.85	-93.3
	7.18	-90.53
	7.78	-106.6
	7.66	-107
	8	-109.75
(Denkinger <i>et al.</i> , 2013)	-0.76	-90.68
(Van Waerebeek <i>et al.</i> , 2009)	4.8	-1.95
	5.3	-4.02
	2.75	-2.4
	3.68	-2.16
(Weir, 2010)	4.41	-0.83
	-15.92	-5.72
	-11.8	11.7
	-2.15	-41.57
	-8.4	-34.33
	-7.35	-34.37
	-15.68	-38.07
	-24.28	-44.18
	-23.64	-41.14
	-22.89	-40.71
	-24.36	-44.08
	-27.11	-46.37
(Moreno <i>et al.</i> , 2005b)	-3.86	-32.46
	-23.38	-41.11
	-9.7	-35.01
	-25.58	-44.32
	-3.85	-32.42
	-24.78	-43.92
	-2.87	-41.63
	-15.9	-38.02
	-3.83	-32.42
	-3.83	-32.42
	-3.83	-32.42
This study	-13.94	-38.16

Steno bredanensis

Reference	Latitude	Longitude
	-30.13	-50.2
	-30.48	-50.33
(Ott & Danilewicz, 1996)	-29.36	-46.5
	-30.01	-50.1
	-30.01	-50.08
	-27.5	-48.4
(Ott & Danilewicz, 1996)	29.28	-94.79
	29.44	-94.63
	-21.61	-41.01
(Siciliano, 1994)	-22.93	-43.25
	-25.01	-47.91
	-27.61	-48.53
(Simões-Lopes & Ximenez, 1993)	-27.49	-48.4
	-27.46	-48.37
	10.72	-66.5
(Romero <i>et al.</i> , 2001)	10.36	-64.38
	28	-96
(Fulling <i>et al.</i> , 2003)	28	-86
	5.51	-87.08
(Fertl <i>et al.</i> , 1999)		
(Di Benedetto & Ramos, 2001)	-21.58	-40.98
(Eyre, 1995)	-23.01	-43.36
	-11.41	58.58
	-27.35	-48.4
(Soto & Montibeler, 2000)	-26.77	-46.78
	-30.25	-50.1
	-31.91	-51.34
	-26.19	-48.61
	-3.71	-38.54
(Alves-Júnior <i>et al.</i> , 1996)	-4.17	-38.08
	-3.5	-38.9
	-3.54	-38.83
	-3.93	-38.3
	35.93	-5.64
	32.82	-16.99
(Jefferson <i>et al.</i> , 1997)	14.58	-17.33
	18.15	-16.33
	5.03	-4.92
	15.16	-23.53
	28.44	-16.65
(Denkinger <i>et al.</i> , 2013)		
	3.59	3.73
	-0.76	-90.68
(Van Waerebeek <i>et al.</i> , 2009)	5.28	-0.73
	5.21	-3.98

	-19.33	12.58
	5.27	-0.73
(Weir, 2010)	4.16	0.43
	4.18	0.33
	-15.92	-5.72

<i>Tursiops aduncus</i>		
Reference	Latitude	Longitude
	19.75	107.74
(Wang <i>et al.</i> , 2000)	24.80	120.90
	23.53	119.62
	-3.65	113.26
(Peddemors, 1999)	-34.1	18.8
(Charlton-Robb <i>et al.</i> , 2011)	-19.71	148.46
(Perrin <i>et al.</i> , 2007)	15.33	40.66
	32.50	130.22
(Kurihara & Oda, 2006)	28.40	129.50
	35.65	139.76
	-14.42	144.63
	17.63	83.25
	5.97	81.08
	-2.47	40.80
	25.12	66.62
	-30.12	30.85
	-29.85	31.04
	-30.57	30.57
	-29.92	31.02
	-31.68	29.45
(Kurihara & Oda, 2007)	-29.72	31.08
	23.53	119.62
	24.80	120.90
	23.56	119.57
	24.61	120.74
	23.6	119.50
	25.04	121.46
	23.59	119.66
	23.58	119.64
	28.40	129.50
	-9.58	160.73
	28.97	50.82
(Stensland <i>et al.</i> , 2006)	-6.43	39.45
(Möller & Beheregaray, 2004)	-32.7	152.1
	-35.11	150.7
(Heithaus, 2001)	-25.75	113.73

<i>Tursiops gephyreus</i>		
Reference	Latitude	Longitude
	-25.62	-48.42
	-32.01	-52.13
	-32.19	-52.16
	-32.15	-52.08
	-31.94	-51.86
	-32.15	-52.08
	-32.62	-52.42
	-31.85	-51.72
	-32.54	-52.39
	-31.28	-50.95
	-32.16	-52.1
	-32.31	-52.27
	-30.44	-50.3
	-32.1	-52.03
	-32.32	-52.28
	-32.22	-52.19
	-33.64	-53.22
	-32.25	-52.23
	-31.58	-51.27
	-32.15	-52.08
(Wickert, 2013)	-32.04	-51.98
	-31.61	-51.31
	-32.19	-52.15
	-32.56	-52.4
	-32.05	-51.99
	-32.06	-51.99
	-31.47	-51.16
	-31.23	-50.9
	-27.61	-48.55
	-27.74	-48.63
	-28.32	-48.71
	-27.6	-48.43
	-28.48	-48.77
	-28.88	-49.29
	-27.61	-48.55
	-27.78	-48.53
	-27.61	-48.55
	-27.61	-48.53
	-28.49	-48.77
	-28.49	-48.77
	-26.25	-48.64

-27.14 -48.51
 -26.88 -48.64
 -26.96 -48.63
 -30.59 -50.39
 -37.99 -57.54
 -36.37 -56.71
 -33.76 -53.39
 -34.78 -55.74
 -34.4 -53.79
 -34.65 -54.15
 -34.8 -55.89
 -34.6 -58.35
 -38.27 -57.83
 -36.52 -56.69
 -36.37 -56.71
 -38.27 -57.83
 -34.6 -58.35
 -34.71 -58.22
 -35.74 -57.36
 -35.28 -57.22
 -36.37 -56.71
 -34.92 -56.14
 -34.93 -56.16
 -34.53 -56.03
 -34.41 -53.78
 -34.8 -55.38
 -34.91 -55.13
 -34.79 -55.87
 -34.84 -55.97
 -34.28 -53.78
 -34.67 -54.15
 -34.67 -54.15
 -30.54 -50.36
 -30.79 -50.54
 -29.33 -49.72
 -31.34 -51.01
 -30.07 -50.16
 -30.45 -50.31
 -29.71 -49.99
 -30.72 -50.49
 -31.23 -50.88
 -30.48 -50.32
 -31.23 -50.88
 -29.91 -50.09
 -30.79 -50.54
 -29.88 -50.07

-31.2 -50.86
 -30.33 -50.26
 -30.04 -50.15
 -29.98 -50.12
 -30.45 -50.31
 -29.9 -50.08
 -30.15 -50.19
 -31.19 -50.84
 -30.18 -50.2
 -29.19 -49.6
 -30.75 -50.51
 -31.13 -50.78
 -30.03 -50.15
 -30.47 -50.32
 -43.33 -65.05
 -42.77 -64.25
 -42.98 -64.31
 -41.42 -65.03
 -40.85 -65.13
 -40.78 -65.04
 -37.93 -57.53

<i>Tursiops truncatus</i>		
Reference	Latitude	Longitude
(Nieri <i>et al.</i> , 1999)	18.03	-16.15
	22.34	114.07
	25.14	121.75
(Wang <i>et al.</i> , 2000)	23.53	119.62
	24.58	121.87
	23.03	120.05
(Lucas & Hooker, 1997)	44.61	-64.01
(Jefferson, 1996b)	26.89	-83.38
(Robineau & Vely, 1997)	29.7	-87
	28.12	-96.03
(Bearzi <i>et al.</i> , 1998)	20.85	-96.06
(Baird <i>et al.</i> , 2001)	19.33	-16.51
(Lucena <i>et al.</i> , 1998)	14.77	-17.42
	44.58	14.5
	20.7	-156.7
	-7.13	-34.81
(Jefferson & Baumgardner, 1997)	27.96	-96.94
	28.06	-97.03
	28.03	-97.03
	28.94	-95.28
	26.11	-97.16

	29.68	-93.89
	29.36	-94.86
	29.32	-94.78
	29.28	-94.79
	29.23	-94.88
	29.3	-94.76
	29.32	-94.73
	29.33	-94.73
	29.46	-94.57
	29.44	-94.63
	29.54	-94.38
	29.5	-94.49
	29.66	-94.97
	29.63	-94.13
	29.5	-94.5
	29.66	-94.07
	27.39	-97.29
	28.62	-95.82
	27.84	-97.37
	27.81	-97.06
(Siciliano, 1994)	27.69	-97.31
	27.76	-97.28
	46.6	-60.34
	-20.67	-40.49
(Simões-Lopes, 1998)	-21.61	-41.01
	-22.93	-43.25
(Júnior <i>et al.</i> , 1999)		
	-25.01	-47.91
(Geise & Borobia, 1987)	27	-78
(Debrot, 1998)	-22.93	-43.17
(Simões-Lopes & Ximenez, 1993)	-22.88	-42.01
	12.11	-68.96
(Walsh <i>et al.</i> , 1988)	32.86	-117.25
	33.14	-117.36
	29.35	-94.77
	26.11	-80.1
(Gales <i>et al.</i> , 1992)	27.71	-80.37
	26.63	-81.88
	27.5	-82.71
(Dolar <i>et al.</i> , 1997)	-41.15	146.58
	-42.9	147.43
(Romero <i>et al.</i> , 2001)	-43.31	147.01
	7.76	118.53
	10.73	-61.8

	10.98	-63.8
	10.88	-64.08
	11	-64.08
	10.8	-64.16
	10.48	-64.18
	10.66	-64.25
	10.58	-64.28
	10.25	-64.41
	10.83	-64.61
	10.1	-65.2
	10.5	-66.08
(Weller <i>et al.</i> , 1997)	10.63	-66.73
	10.83	-68.25
	11.66	-71.66
	29.33	-94.66
	32.23	-80.88
(Silber & Fertl, 1995)	32.21	-80.75
	31.48	-81.26
	31.47	-81.2
	27.87	-97.04
	29.87	-89.32
	25.65	-112.1
	26.2	-111.19
(Fertl <i>et al.</i> , 2002)	27.63	-111.58
(Fertl & Schiro, 1994)	38.49	-8.92
	18.15	-16.33
	27.18	-82.49
	27.93	-97
(Fulling <i>et al.</i> , 2003)	27.83	-97.05
	26.56	-97.28
	28	-96
	28	-90
(Fertl <i>et al.</i> , 1999)	28	-83
	28.46	-90.15
	30.36	-89.09
	35.18	-75.67
(Cañadas <i>et al.</i> , 2002)	-41.04	173.29
(Silber <i>et al.</i> , 1994)	16.64	-22.94
(Breese & Tershy, 1993)	53.3	5.37
(Di Benedetto & Ramos, 2001)	36.76	-2.42
	30	-114
(Perrin <i>et al.</i> , 1985)	21.58	-40.98
	-21.58	-40.98
	-0.7	-89.5

	-0.76	-89.5
	-1.26	-90.36
(Robineau & Vely, 1998)	-0.83	-89.68
	-0.1	-90.86
	-0.63	-91.55
	21.17	-17.6
	20.76	-17.36
	19.36	-16.84
	18.11	-16.33
	16.17	-16.94
	-25.59	153.33
	-24.62	153.44
	-11.2	142.89
	-9	131.55
(Eyre, 1995)	12.22	50.92
	12.28	50.25
	12.29	50.1
	12.51	44
	12.06	43.96
	12.78	43.28
	13.31	43.12
	15.11	42.03
	15.14	42
(Peddemors, 1999)	28.37	33.21
(Santos, 1997)	28.5	33.12
	31.89	31.2
(Cárdenas <i>et al.</i> , 1991)	35.8	15.22
	-23	14.96
	-23.8	-45.4
	-23.61	-45.38
	-33.69	-78.94
	49.03	-12.85
(Berrow & Rogan, 1998)	27.16	-80.58
	36.83	-75.91
	27.33	-82.66
	28	-97
	34.7	-76.91
	34.76	-76.68
	29.01	-80.53
	27.18	-80.15
(Fertl & Landry, 1999)	39.33	-74.36
(Alves-Júnior <i>et al.</i> , 1996)	-29.7	-92.88
	40.96	-66.4
	41.91	-70.01

(MacLeod <i>et al.</i> , 2004)	29.27	-94.81
	-2.8	-40.51
	-3.71	-38.54
	-2.94	-39.8
	-22.88	14.55
(Sekiguchi <i>et al.</i> , 1992)	-34.66	19.5
	-34.43	19.15
	-32.71	17.95
	-34.18	22.13
	-34.46	19.36
	-34.45	19.31
(Van Waerebeek <i>et al.</i> , 1998)	-32.75	18.01
	-34.38	21.41
	-34.38	18.83
	-5.73	-80.86
	34.55	18.04
(Jefferson <i>et al.</i> , 1997)	35.93	-5.64
	28.44	-16.65
	32.82	-16.99
	32.79	-9.01
	18.15	-16.33
	14.58	-17.33
	15.16	-23.53
(Read <i>et al.</i> , 1988)	11.65	-15.6
	5.03	-4.92
	-12.46	-76.79
(Cockcroft, 1992)	-13.03	-76.48
	-9.08	-78.59
	-12.11	-77.08
(Corsolini <i>et al.</i> , 1995)	-29.86	31.04
	44.41	12.31
	43.91	12.91
	44.2	12.41
	43.98	12.69
	44.33	12.34
(Borrell <i>et al.</i> , 2006)	45.21	12.3
	41.23	1.96
	39.46	-0.31
	39.48	2.68
(Charlton-Robb <i>et al.</i> , 2011)	37.19	-7.05
	38.99	-9.5
(Denkinger <i>et al.</i> , 2013)	-38.6	144.77

	-40.95	147.4			
(Kurihara & Oda, 2006)	-43.28	147.89		-25.62	-48.42
	-0.76	-90.68		-25.8	-48.47
	34.75	137.25		-25.8	-48.51
	50.41	-5.08		-24.75	-47.55
				-24.75	-47.55
(Kurihara & Oda, 2007)	33.59	135.94		-24.75	-47.55
	34.93	139.14		-24.75	-47.55
	34.66	138.2		-25.73	-48.47
	12.58	74.67		-24.75	-47.55
	8.46	76.92		-25.73	-48.47
	23.91	120.09		-25.73	-48.47
	23.67	119.56		-24.98	-47.95
	23.61	119.6		-24.75	-47.55
	23.49	121.5		-24.75	-47.55
	33.59	135.94		-24.75	-47.55
(Van Waerebeek <i>et al.</i> , 2009)	34.93	139.14		-23.01	-43.37
	37.17	138.23		-22.88	-42.02
	5.51	-0.21		-23.17	-44.13
	5.38	-0.48		-22.97	-43.01
(Stockin & Visser, 2005)				-22.94	-42.5
	6.34	2.44		-22.96	-42.75
(Weir, 2010)	5.24	-4.03		-22.96	-42.84
	5.3	-4.02		-22.89	-42.03
	-36.61	174.81		-4.4	-37.78
	5.21	-3.98		-4.57	-37.65
	5.38	-0.48		-2.81	-40.41
	5.61	-0.03		-3.69	-38.58
	5.54	-0.2		-3.71	-38.55
	-2	9.58		-3.41	-39.04
	-15.92	-5.72		-30.89	-50.63
	0.34	6.72		-22.72	-41.98
(Wickert, 2013)	-24.75	-47.55		-22.29	-42.29
	-25.57	-48.36		-22.95	-42.17
	-25.73	-48.47		-23.03	-43.49
	-24.75	-47.55		-22.76	-41.91
	-22.88	-42.02		-22.97	-41.97
	-22.97	-43.07		-22.72	-41.98
	-12.57	-38		-22.86	-41.99
	-25.28	-48.75		-22.19	-41.4
	-25.57	-48.36		-21.2	-40.58
	-25.55	-48.3		-22.78	-41.9
	-25.73	-48.47		-22.72	-41.98
	-25.8	-48.51		-27.44	-48.39
	-25.59	-48.34		-27.71	-48.5
	-25.57	-48.36		-27.59	-48.42
	-25.88	-48.58		-27.45	-48.53

-28.7 -49.02
-27.44 -48.39
-28.41 -48.75
-27.59 -48.42
-26.22 -48.52
-27.94 -48.54
-27.63 -48.45
-26.47 -48.61
-26.24 -48.5
-26.46 -48.6
-26.25 -48.64
-26.4 -48.59
-26.25 -48.64
-26.34 -48.56
-26.12 -48.6
-26.24 -48.5
-8.5 -35
-7.77 -34.83
-7.81 -34.84
-7.94 -34.82
-8.09 -34.88
-6.84 -34.91
-26.76 -48.67
-28.16 -48.66
-27.39 -48.43
-26.08 -48.6
-27 -48.58
-26.99 -48.63
-26.99 -48.63
-26.77 -48.66
-0.6 -47.54
-2.07 -4.8
-34.17 -53.68
-38.21 -57.7
-29.96 -50.11
-30.35 -50.27
-30.34 -50.27
-30 -50.13
-30.76 -50.52
-31.11 -50.77
-29.97 -50.11
-30.19 -50.21
-31.34 -51.01
-30.34 -50.27
-30.34 -50.27
-29.36 -49.74

	-30.73	-50.5
	-30.53	-50.35
	-30.43	-50.3
	-29.89	-50.08
	-17.74	-39.27
	-12.99	-38.43
	-12.97	-38.51
	-13.24	-38.95
	-12.91	-38.3
	19.77	57.87
	9.94	51
(Ballance & Pitman, 1998)	-3.57	55.33
	1.95	73.46
	5.97	81.08
	8.09	66.67

REFERENCES

- Alves-Júnior, T., Ávila, F., de Oliveira, J., Furtado-Neto, M. & Monteiro-Neto, C. (1996) Registros de cetáceos para o litoral do estado do Ceará, Brasil. *Arquivos de Ciências do Mar*, **30**, 79-92.
- Amano, M., Miyazaki, N. & Yanagisawa, F. (1996) Life history of Fraser's dolphin, *Lagenodelphis hosei*, based on a school captured off the Pacific coast of Japan. *Marine Mammal Science*, **12**, 199-214.
- Anderson, R., Shaan, A. & Waheed, Z. (1999) Records of cetacean 'strandings' from the Maldives. *J. South Asian Nat. Hist*, **4**, 187-202.
- Azevedo, A.F., Laison-Brito, J., Siciliano, S., Cunha, H.A. & Fragoso, A.B. (2003) Colour pattern and external morphology of the Fraser's dolphin (*Lagenodelphis hosei*) in the Southwestern Atlantic. *Aquatic Mammals*, **29**, 411-416.
- Baird, R.W., Ligon, A.D., Hooker, S.K. & Gorgone, A.M. (2001) Subsurface and nighttime behaviour of pantropical spotted dolphins in Hawai'i. *Canadian Journal of Zoology*, **79**, 988-996.
- Ballance, L.T. & Pitman, R.L. (1998) Cetaceans of the western tropical Indian Ocean: distribution, relative abundance, and comparisons with cetacean communities of two other

- tropical ecosystems. *Marine Mammal Science*, **14**, 429-459.
- Barreto, A. & Lodi, L. (2000) Estimativa de idades do golfinho-rotador, *Stenella longirostris*, (Cetacea, Delphinidae) no nordeste do Brasil. *Bioikos*, **14**
- Bastida, R., Rodríguez, D., Desojo, J. & Rivero, L. (2001) La presencia del delfín listado, *Stenella coeruleoalba* (Meyen, 1833), en el Mar Argentino. *Mastozoología Neotropical*, **8**, 111-127.
- Bearzi, G. (2000) First report of a common dolphin (*Delphinus delphis*) death following penetration of a biopsy dart. *Journal of Cetacean Research and Management*, **2**, 217-222.
- Bearzi, G., Fortuna, C.M. & Notarbartolo di Sciara, G. (1998) Unusual sighting of a striped dolphin (*Stenella coeruleoalba*) in the Kvarneric, northern Adriatic Sea. *Natura Croatica*, **7**, 169-176.
- Berrow, S. & Rogan, E. (1998) Incidental capture of cetaceans in Irish waters. *The Irish Naturalists' Journal*, 22-31.
- Blanco, C., Aznar, J. & Raga, J. (1995) Cephalopods in the diet of the striped dolphin *Stenella coeruleoalba* from the western Mediterranean during an epizootic in 1990. *Journal of Zoology*, **237**, 151-158.
- Bloch, D., Desportes, G., Petersen, A. & Sigurjónsson, J. (1996) Strandings of striped dolphins (*Stenella coeruleoalba*) in Iceland and the Faroe Islands and sightings in the northeast Atlantic, north of 50 N latitude. *Marine Mammal Science*, **12**, 125-132.
- Bones, M., Neill, B. & Reid, B. (1998) Fraser's dolphin (*Lagenodelphis hosei*) stranded in South Uist: first record in UK waters. *Journal of Zoology*, **246**, 460-461.
- Borrell, A., Cantos, G., Pastor, T. & Aguilar, A. (2004) Levels of organochlorine compounds in spotted dolphins from the Coiba archipelago, Panama. *Chemosphere*, **54**, 669-677.
- Borrell, A., Aguilar, A., Tornero, V., Sequeira, M., Fernandez, G. & Alís, S. (2006) Organochlorine compounds and stable isotopes indicate bottlenose dolphin subpopulation structure around the Iberian Peninsula. *Environment International*, **32**, 516-523.
- Breese, D. & Tershy, B.R. (1993) Relative abundance of Cetacea in the Canal de Ballenas, Gulf of California. *Marine Mammal Science*, **9**, 319-324.
- Caldwell, D.K., Caldwell, M.C. & Walker, R.V. (1976) First records for Fraser's dolphin (*Lagenodelphis hosei*) in the Atlantic and the melon-headed whale (*Peponocephala electra*) in the western Atlantic. *Biological Systems*.
- Cañadas, A., Sagarminaga, R. & Garcia-Tiscar, S. (2002) Cetacean distribution related with depth and slope in the Mediterranean waters off southern Spain. *Deep Sea Research Part I: Oceanographic Research Papers*, **49**, 2053-2073.
- Cárdenas, J., Yañez, J., Reyes, J. & Van Waerebeek, K. (1991) Nuevos Registros de Cetáceos para el Archipiélago Juan Fernández, Chile. *Bol. Mus. Nac. Hist. Nat.*, 113-120.
- Charlton-Robb, K., Gershwin, L.-a., Thompson, R., Austin, J., Owen, K. & McKechnie, S. (2011) A New Dolphin Species, the Burrnun Dolphin *Tursiops australis* sp. nov., Endemic to Southern Australian Coastal Waters. *PLoS ONE*, **6**, e24047.
- Cipriano, F. (1997) Antitropical distributions and speciation in dolphins of the genus *Lagenorhynchus*: A preliminary analysis. *Molecular Genetics of Marine Mammals* (ed. by A.E. Dizon, S.J. Chivers and W.F. Perrin), pp. 305-316. Society for Marine Mammalogy.
- Cipriano, F. (2009) Atlantic white-sided dolphin, *Lagenorhynchus acutus*. *Encyclopedia of Marine Mammals* (ed. by W.F. Perrin, B. Wursig and J.G.M. Thewissen), pp. 56-58. Academic Press.
- Cockcroft, V. (1992) Incidental capture of bottlenose dolphins (*Tursiops truncatus*) in shark nets: an assessment of some possible causes. *Journal of Zoology*, **226**, 123-134.
- Corsolini, S., Focardi, S., Kannan, K., Tanabe, S., Borrell, A. & Tatsukawa, R. (1995) Congener profile and toxicity assessment of polychlorinated biphenyls in dolphins, sharks and tuna collected from Italian coastal waters.

- Marine Environmental Research*, **40**, 33-53.
- Cremer, M. & Simões-Lopes, P. (1997) Accidental capture of the pantropical spotted dolphin *Stenella attenuata*(Gray, 1846)(Delphinidae) in the southwestern South Atlantic Ocean. *Biociências*, **5**, 231-233.
- Danilewicz, D., Ott, P., Secchi, E., Andriolo, A. & Zerbini, A. (2013) Occurrence of the Atlantic spotted dolphin, *Stenella frontalis*, in the southern Abrolhos Bank, Brazil. *Marine Biodiversity Records*, **6**, 1-3.
- Das, K., Lepoint, G., Loizeau, V., Debacker, V., Dauby, P. & Bouquegneau, J.-M. (2000) Tuna and dolphin associations in the North-East Atlantic: evidence of different ecological niches from stable isotope and heavy metal measurements. *Marine Pollution Bulletin*, **40**, 102-109.
- Debrot, A. (1998) New Cetacean Records for Curacao, Netherlands Antilles. *Caribbean Journal of Science*, **34**, 168-170.
- Denkinger, J., Oña, J., Alarcón, D., Merlen, G., Salazar, S. & Palacios, D.M. (2013) From whaling to whale watching: Cetacean presence and species diversity in the Galápagos Marine Reserve. *Science and Conservation in the Galapagos Islands*, pp. 217-235. Springer.
- Di Benedetto, A.P.M. & Ramos, R.M.A. (2001) Stomach contents of delphinids from Rio de Janeiro, southeastern Brazil. *ATLANTIC*, **2**, 2.
- Dolar, M., Suarez, P., Ponganis, P. & Kooyman, G. (1999) Myoglobin in pelagic small cetaceans. *Journal of Experimental Biology*, **202**, 227-236.
- Dolar, M., Walker, W.A., Kooyman, G.L. & Perrin, W.F. (2003) Comparative feeding ecology of spinner dolphins (*Stenella longirostris*) and Fraser's dolphins (*Lagenodelphis hosei*) in the Sulu Sea. *Marine Mammal Science*, **19**, 1-19.
- Dolar, M.L.L., Perrin, W.F., Yaptinchay, A., Jaaman, S., Santos, M.D., Alava, M.N. & Suliansa, M.S.B. (1997) Preliminary investigation of marine mammal distribution, abundance, and interactions with humans in the southern Sulu Sea. *Asian Marine Biology*, **14**, 61-81.
- Eyre, E.J. (1995) Observations of cetaceans in the Indian Ocean whale sanctuary, May-July 1993. *Report of the International Whaling Commission*, **45**, 419-426.
- Fertl, D. & Schiro, A. (1994) Carrying of dead calves by free-ranging Texas bottlenose dolphins (*Tursiops truncatus*). *Aquatic Mammals*, **20**, 53-56.
- Fertl, D. & Landry, A. (1999) Sharksucker (*Echeneis naucrates*) on a bottlenose dolphin (*Tursiops truncatus*) and a review of other cetacean-remora associations. *Marine Mammal Science*, **15**, 859-863.
- Fertl, D., Schiro, A. & Peake, D. (1997) Coordinated feeding by Clymene dolphins (*Stenella clymene*) in the Gulf of Mexico. *Aquatic Mammals*, **23**, 111-112.
- Fertl, D., Pusser, L. & Long, J. (1999) First record of an albino bottlenose dolphin (*Tursiops truncatus*) in the Gulf of Mexico, with a review of anomalously white cetaceans. *Marine Mammal Science*, **15**, 227-234.
- Fertl, D., Landry, A. & Barros, N. (2002) Sharksucker (*Echeneis naucrates*) on a bottlenose dolphin (*Tursiops truncatus*) from Sarasota Bay, Florida, with comments on remora-cetacean associations in the Gulf of Mexico. *Gulf of Mexico Science*, **20**, 151-152.
- Fertl, D., Jefferson, T.A., Moreno, I.B., Zerbini, A.N. & Mullin, K.D. (2003) Distribution of the Clymene dolphin *Stenella clymene*. *Mammal Review*, **33**, 253-271.
- Forcada, J., Notarbartolo di Sciara, G. & Fabbri, F. (1995) Abundance of fin whales and striped dolphins summering in the Corso-Ligurian Basin. *Mammalia*, **59**, 127-140.
- Frère, C.H., Hale, P.T., Porter, L., Cockcroft, V.G. & Dalebout, M.L. (2008) Phylogenetic analysis of mtDNA sequences suggests revision of humpback dolphin (*Sousa spp.*) taxonomy is needed. *Marine and Freshwater Research*, **59**, 259-268.
- Fulling, G.L., Mullin, K.D. & Hubard, C.W. (2003) Abundance and distribution of

- cetaceans in outer continental shelf waters of the US Gulf of Mexico. *Fishery Bulletin*, **101**, 923-932.
- Gales, R., Pemberton, D., Clarke, M. & Lu, C. (1992) Stomach contents of long-finned pilot whales (*Globicephala melas*) and bottlenose dolphins (*Tursiops truncatus*) in Tasmania. *Marine Mammal Science*, **8**, 405-413.
- Geise, L. & Borobia, M. (1987) Sobre a ocorrência de cetáceos no litoral do Estado do Rio de Janeiro entre 1968 e 1984. *Revista Brasileira de Zoologia*, **4**, 341-346.
- Gilpatrick, J.W. (1987) Summary of distribution records of the spinner dolphin, *Stenella longirostris*, and the pantropical spotted dolphin, *S. attenuata*, from the western Pacific Ocean, Indian Ocean and Red Sea. US Department of Commerce, National Oceanic and Atmospheric Administration, National Marine Fisheries Service, Southwest Fisheries Center.
- Gomes-Pereira, J.N., Marques, R., Cruz, M.J. & Martins, A. (2013) The little-known Fraser's dolphin *Lagenodelphis hosei* in the North Atlantic: new records and a review of distribution. *Marine Biodiversity*, **43**, 321-332.
- Heithaus, M.R. (2001) Shark attacks on bottlenose dolphins (*Tursiops aduncus*) in Shark Bay, Western Australia: attack rate, bite scar frequencies, and attack seasonality. *Marine Mammal Science*, **17**, 526-539.
- Hersh, S.L. & Odell, D.K. (1986) Mass stranding of Fraser's dolphin, *Lagenodelphis hosei*, in the western North Atlantic. *Marine Mammal Science*, **2**, 73-76.
- Herzing, D. & Johnson, C. (1997) Interspecific interactions between Atlantic spotted dolphins (*Stenella frontalis*) and bottlenose dolphins (*Tursiops truncatus*) in the Bahamas, 1985 - 1995. *Aquatic Mammals*, **23**, 85-99.
- Herzing, D.L. (1997) The life history of free-ranging Atlantic spotted dolphins (*Stenella frontalis*): age classes, color phases, and female reproduction. *Marine Mammal Science*, **13**, 576-595.
- Hubbs, C.L., Perrin, W.F. & Balcomb, K.C. (1973) *Stenella coeruleoalba* in the eastern and central tropical Pacific. *Journal of Mammalogy*, 549-552.
- Jefferson, T., Curry, B., Leatherwood, S. & Powell, J. (1997) Dolphins and porpoises of West Africa: a review of records (Cetacea: Delphinidae, Phocoenidae). *Mammalia*, **61**, 87-108.
- Jefferson, T.A. (1996a) Morphology of the Clymene dolphin (*Stenella clymene*) in the northern Gulf of Mexico. *Aquatic Mammals*, **22**, 35-44.
- Jefferson, T.A. (1996b) Estimates of abundance of cetaceans in offshore waters of the northwestern Gulf of Mexico, 1992-1993. *The Southwestern Naturalist*, 279-287.
- Jefferson, T.A. & Baumgardner, G.D. (1997) Osteological specimens of marine mammals (Cetacea and Sirenia) from the western Gulf of Mexico. *Texas Journal of Science*, **49**, 97-108.
- Jefferson, T.A. & Van Waerebeek, K. (2004) Geographic variation in skull morphology of humpback dolphins (*Sousa spp.*). *Aquatic Mammals*, **30**, 3-17.
- Jefferson, T.A., Leatherwood, S. & Webber, M.A. (1993) *Marine Mammals of the World*. FAO, Rome.
- Jefferson, T.A., Odell, D.K. & Prunier, K.T. (1995) Notes on the biology of the Clymene dolphin (*Stenella clymene*) in the northern Gulf of Mexico. *Marine Mammal Science*, **11**, 564-573.
- Júnior, A., Teixeira, T. & Monteiro Neto, C. (1999) Caracterização morfológica e morfométrica craniana do boto cinza, *Sotalia fluviatilis* Gervais, 1853, da Costa do Estado do Ceará, Brasil.
- Kasuya, T. (1976) Reconsideration of life history parameters of the spotted and striped dolphins based on cemental layers. *Sci. Rep. Whales Res. Inst*, **28**, 73-106.
- Kim, H.W., An, Y.-R. & Kim, Z.G. (2013) First Record of the Fraser's Dolphin (*Lagenodelphis hosei*) in Korean Waters. *Journal of Animal Systematics, Evolution and Diversity*, **29**, 175-178.

- Kurihara, N. & Oda, S.-i. (2006) Cranial variation and taxonomic revision of bottlenose dolphins (*Tursiops spp.*) from Japanese waters. *Aquatic Mammals*, **32**, 289-300.
- Kurihara, N. & Oda, S.-i. (2007) Cranial variation in bottlenose dolphins *Tursiops spp.* from the Indian and western Pacific Oceans: additional evidence for two species. *Acta Theriologica*, **52**, 403-418.
- Lucas, Z.N. & Hooker, S.K. (1997) Cetacean strandings on Sable Island, Nova Scotia, 1990-1996. In. Paper SC/49/06 presented to the IWC Scientific Committee
- Lucena, A., Paludo, D. & Langguth, A. (1998) New records of Odontoceti (Cetacea) from the coast of Paraíba, Brazil. *Revista Nordestina de Biologia*, **12**, 19-27.
- MacLeod, C.D., Hauser, N. & Peckham, H. (2004) Diversity, relative density and structure of the cetacean community in summer months east of Great Abaco, Bahamas. *Journal of the Marine Biological Association of the UK*, **84**, 469-474.
- Maia-Nogueira, R., Farias, T.S., da Cunha, I.F., Dórea-Reis, L.W. & Braga, F.L. (2001) Primeiro registro de *Stenella coeruleoalba* Meyer, 1833 [Cetacea, Delphinidae] no litoral do estado da Bahia, incluindo uma revisão da espécie em águas brasileiras. *Bioikos*, **15**
- Marsili, L. & Focardi, S. (1996) Organochlorine levels in subcutaneous blubber biopsies of fin whales *Balaenoptera physalus* and striped dolphins *Stenella coeruleoalba* from the Mediterranean Sea. *Environmental Pollution*, **91**, 1-9.
- Marsili, L., Casini, C., Marini, L., Regoli, A. & Focardi, S. (1997) Age, growth and organochlorines (HCB, DDTs and PCBs) in Mediterranean striped dolphins *Stenella coeruleoalba* stranded in 1988-1994 on the coasts of Italy. *Marine Ecology Progress Series*, **151**, 273-282.
- McCull, K. & Obendorf, D. (1982) Helminth parasites and associated pathology in stranded Fraser's dolphins, *Lagenodelphis hosei* (Fraser, 1956). *Aquatic Mammals*, **9**, 30-34.
- Mignucci-Giannoni, A., Swartz, S.L., MARTINEZ, A., Burks, C.M. & Watkins, W. (2003) First records of the pantropical spotted dolphin (*Stenella attenuata*) for the Puerto Rican Bank, with a review of the species in the Caribbean. *Caribbean Journal of Science*, **39**, 381-391.
- Miyazaki, N. & Wada, S. (1978) Fraser's dolphin, *Lagenodelphis hosei* in the Western North Pacific. *Scientific Reports of the Whales Research Institute*,
- Möller, L.M. & Beheregaray, L.B. (2004) Genetic evidence for sex-biased dispersal in resident bottlenose dolphins (*Tursiops aduncus*). *Molecular Ecology*, **13**, 1607-1612.
- Moreno, I.B., Danilewicz, D., Borges-Martins, M., Ott, P.H., Caon, G. & Oliveira, L.R. (2003) Fraser's dolphin (*Lagenodelphis hosei* Fraser, 1956) in southern Brazil. *Latin American Journal of Aquatic Mammals*, **2**, 39-46.
- Moreno, I.B., Zerbini, A.N., Danilewicz, D., Santos, M.C.D., Simoes-Lopes, P.C., Lailson-Brito, J. & Azevedo, A.F. (2005) Distribution and habitat characteristics of dolphins of the genus *Stenella* (Cetacea : Delphinidae) in the southwest Atlantic Ocean. *Marine Ecology Progress Series*, **300**, 229-240.
- Nieri, M., Grau, E., Lamarche, B. & Aguilar, A. (1999) Mass mortality of Atlantic spotted dolphins (*Stenella frontalis*) caused by a fishing interaction in Mauritania. *Marine Mammal Science*, **15**, 847-854.
- Odell, D.K. & Chapman, C. (1976) A striped dolphin, *Stenella coeruleoalba*, from Florida. *Biological Systems*.
- Ohizumi, H., Yoshioka, M., Mori, K. & Miyazaki, N. (1998) Stomach contents of common dolphins (*Delphinus delphis*) in the pelagic western North Pacific. *Marine Mammal Science*, **14**, 835-844.
- Peddemors, V. (1999) Delphinids of southern Africa: a review of their distribution, status and life history. *Journal of*

- Cetacean Research and Management*, **1**, 157-165.
- Perrin, W. (1973) Rediscovery of Fraser's dolphin *Lagenodelphis hosei*. *Nature*, **241**, 345-350.
- Perrin, W. (1990) Subspecies of *Stenella longirostris* (Mammalia: Cetacea: Delphinidae). *Proceedings of the Biological Society of Washington*, **103**, 453-463.
- Perrin, W., Caldwell, D. & Caldwell, M. (1994) Atlantic Spotted Dolphin *Stenella frontalis* (G. Cuvier, 1829). *Handbook of marine mammals*, **5**, 173 - 190.
- Perrin, W., Mitchell, E., Mead, J., Caldwell, D. & Van Bree, P. (1981) *Stenella clymene*, a rediscovered tropical dolphin of the Atlantic. *Journal of Mammalogy*, 583-598.
- Perrin, W.F. (1975) Variation of spotted and spinner porpoise (genus *Stenella*) in the Eastern Pacific and Hawaii. *Bulletin of the Scripps Institution of Oceanography of the University of California*, **21**
- Perrin, W.F. (1994) *Comparison of the resolving power of metric and non-metric cranial characters in defining geographical populations of dolphins*. Natural History Museum of Los Angeles County.
- Perrin, W.F. & Roberts, E.L. (1972) Organ weights of non-captive porpoise (*Stenella* spp.). *Bulletin of the Southern California Academy of Sciences*, **71**, 19-32.
- Perrin, W.F., Scott, M.D., Walker, G.J. & Cass, V.L. (1985) Review of geographical stocks of tropical dolphins (*Stenella* spp. and *Delphinus delphis*) in the eastern Pacific.
- Perrin, W.F., Dolar, M., Amano, M. & Hayano, A. (2003) Cranial sexual dimorphism and geographic variation in Fraser's dolphin, *Lagenodelphis hosei*. *Marine Mammal Science*, **19**, 484-501.
- Perrin, W.F., Robertson, K.M., Van Bree, P.J. & Mead, J.G. (2007) Cranial description and genetic identity of the holotype specimen of *Tursiops aduncus* (Ehrenberg, 1832). *Marine Mammal Science*, **23**, 343-357.
- Perrin, W.F., Mitchell, E.D., Mead, J., Caldwell, D.K., Caldwell, M.C., van Bree, P.J.H. & Dawbin, W.H. (1987) Revision of the spotted dolphins, *Stenella* spp. *Marine Mammal Science*, **3**, 99-170.
- Perrin, W.F., Armstrong, W.A., Baker, A.N., Barlow, J., Benson, S.R., Collet, A.S., Cotton, J.M., Ever-Hart, D.M., Farley, T.D. & Mellon, R.M. (1995) An anomalously pigmented form of the short-beaked common dolphin (*Delphinus delphis*) from the Southwestern Pacific, Eastern Pacific, and Eastern Atlantic *Marine Mammal Science*, **11**, 241-247.
- Read, A.J., Van Waerebeek, K., Reyes, J.C., McKinnon, J.S. & Lehman, L.C. (1988) The exploitation of small cetaceans in coastal Peru. *Biological Conservation*, **46**, 53-70.
- Reynoso, J.P. (1985) Notas acerca de un ejemplar del delfín listado *Stenella coeruleoalba* (Cetacea: Delphinidae), en San Blas, Nayarit, México. *An. Inst. Biol. Univ. Autón. Méx.*, **56**, 1035-1038.
- Robineau, D. & Rose, J.-M. (1983) Note sur le *Stenella longirostris* (Cetacea, Delphinidae) du golfe d'Aden. *Mammalia*, **47**, 237-246.
- Robineau, D. & Vely, M. (1997) Données préliminaires (taille corporelle, craniométrie) sur le grand dauphin (*Tursiops truncatus*) des côtes d'Afrique du nord-ouest (Mauritanie, Sénégal). *Mammalia*, **61**, 443-448.
- Robineau, D. & Vely, M. (1998) Les cétacés des côtes de Mauritanie (Afrique du nord-ouest). Particularités et variations spatio-temporelles de répartition: rôle des facteurs océanographiques. *Revue d'écologie*, **53**, 123-152.
- Robineau, D., Vely, M. & Maigret, J. (1994) *Stenella clymene* (Cetacea, Delphinidae) from the coast of West Africa. *Journal of Mammalogy*, **75**, 766-767.
- Robison, B. & Craddock, J. (1983) Mesopelagic fishes eaten by Fraser's dolphin, *Lagenodelphis hosei*. *Fishery bulletin-United States, National Marine Fisheries Service*, **81**
- Rogan, E., Baker, J., Jepson, P., Berrow, S. & Kiely, O. (1997) A mass stranding of

- white-sided dolphins (*Lagenorhynchus acutus*) in Ireland: biological and pathological studies. *Journal of Zoology*, **242**, 217-227.
- Romero, A., Agudo, A.I., Green, S.M. & di Sciara, G.N. (2001) Cetaceans of Venezuela: their distribution and conservation status.
- Rosas, F.C., Monteiro-Filho, E.L., Marigo, J., Santos, R.A., Andrade, A., Rautenberg, M., Oliveira, M. & Bordignon, M. (2002) The striped dolphin, *Stenella coeruleoalba* (Cetacea: Delphinidae), on the coast of São Paulo State, southeastern Brazil. *Aquatic Mammals*, **28**, 60-66.
- Santos, M.C.O. (1997) Lone sociable bottlenose dolphin in Brazil: Human fatality and management. *Marine Mammal Science*, **13**, 355-356.
- Secchi, E. & Siciliano, S. (1995) Comments on the southern range of the spinner dolphin (*Stenella longirostris*) in the western South Atlantic. *Aquatic Mammals*, **21**, 105-105.
- Sekiguchi, K., Klages, N. & Best, P. (1992) Comparative analysis of the diets of smaller odontocete cetaceans along the coast of southern Africa. *South African Journal of Marine Science*, **12**, 843-861.
- Selzer, L.A. & Payne, P.M. (1988) The distribution of white-sided (*Lagenorhynchus acutus*) and common dolphins (*Delphinus delphis*) vs. environmental features of the continental shelf of the Northeastern United States. *Marine Mammal Science*, **4**, 141-153.
- Siciliano, S. (1994) Review of small cetaceans and fishery interactions in coastal waters of Brazil. *Report of the International Whaling Commission*, **15**, 241-250.
- Silber, G.K. & Fertl, D. (1995) Intentional beaching by bottlenose dolphins (*Tursiops truncatus*) in the Colorado River Delta, Mexico. *Aquatic Mammals*, **21**, 183-186.
- Silber, G.K., Newcomer, M.W., Silber, P.C., Pérez-Cortés, M. & Ellis, G.M. (1994) Cetaceans of the northern Gulf of California: distribution, occurrence, and relative abundance. *Marine Mammal Science*, **10**, 283-298.
- Silva, M. (1999) Diet of common dolphins, *Delphinus delphis*, off the Portuguese continental coast. *Journal of the Marine Biological Association of the UK*, **79**, 531-540.
- Simões-Lopes, P.C. (1998) Intraspecific agonistic behavior of *Tursiops truncatus* (Cetacea, Delphinidae) during dolphin-human cooperative fishing in southern Brazil. *Biotemas*, **11**, 165-171.
- Simões-Lopes, P.C. & Ximenez, A. (1993) Annotated list of the cetaceans of Santa Catarina coastal waters, southern Brazil. *Biotemas*, **6**, 67-92.
- Simões-Lopes, P., Praderi, P. & Paula, G.d.S. (1994) The clymene dolphin, *Stenella clymene* (Gray, 1846), in the southwestern south Atlantic Ocean. *Marine Mammal Science*, **10**, 213-217.
- Soto, J., Montibeler, A. & da Silva-Ribiero, C. (2000) O golfinho-de-capacete, *Stenella clymene* (Gray, 1846) (Cetacea, Delphinidae) no sudoeste do Atlântico. *Alcance-Itajai*, **7**, 65-68.
- Soto, J.M.R. & Caseca-Santos, L. (1999) O golfinho rotador, *Stenella longirostris* (Gray, 1828) (Cetacea: Delphinidae), no Sudoeste do Atlântico. *Alcance-Itajai*, **6**, 39-43.
- Soto, J.M.R. & Montibeler, A. (2000) O golfinho-de-dentes-rugosos, *Steno bredanensis* (Lesson, 1828) (Cetacea, Delphinidae), no sul do Brasil. *Alcance-Itajai*, **4**, 79-86.
- Stensland, E., Carlén, I., Särnblad, A., Bignert, A. & Berggren, P. (2006) Population size, distribution, and behavior of Indo-Pacific bottlenose (*Tursiops aduncus*) and humpback (*Sousa chinensis*) dolphins off the South coast of Zanzibar *Marine Mammal Science*, **22**, 667-682.
- Stockin, K.A. & Visser, I.N. (2005) Anomalous Pigmented Common Dolphins (*Delphinus Dolphins*) off Northern New Zealand. *Aquatic Mammals*, **31**, 43-51.
- Tanabe, S., Watanabe, S., Kan, H. & Tatsukawa, R. (1988) Capacity and mode of PCB metabolism in small cetaceans. *Marine Mammal Science*, **4**, 103-124.

- Tavares, M., Moreno, I.B., Siciliano, S., Rodriguez, D., SANTOS, D.O., Marcos, C., LAILSON-BRITO Jr, J. & FABIÁN, M.E. (2010) Biogeography of common dolphins (genus *Delphinus*) in the Southwestern Atlantic Ocean. *Mammal Review*, **40**, 40-64.
- Torda, G., Suárez, P.L. & Jurado, L.L. (2010) First records of Fraser's Dolphin *Lagenodelphis hosei* for the Cape Verde Islands. *Zoologia Caboverdiana*, **1**, 71-73.
- Van Bree, P. (1971) On skulls of *Stenella longirostris* (Gray, 1828) from the eastern Atlantic (Notes on Cetacea, Delphinoidea IV). *Beaufortia*, **19**, 99-106.
- Van Bree, P., Collet, A., Desportes, G., Hussenot, E. & Raga, J. (1986) Le dauphin de Fraser, *Lagenodelphis hosei* (Cetacea, Odontoceti), espèce nouvelle pour la faune d'Europe. *Mammalia*, **50**, 57-86.
- Van Waerebeek, K., Ofori-Danson, P. & Debrah, J. (2009) The cetaceans of Ghana, a validated faunal checklist. *West African Journal of Applied Ecology*, **15**
- Van Waerebeek, K., Felix, F., Haase, B., Palacios, D.M., Mora-Pinto, D.M. & Munoz-Hincapie, M. (1998) Inshore records of the striped dolphin, *Stenella coeruleoalba*, from the Pacific coast of South America. *Report of the International Whaling Commission*, **48**, 525-532.
- Walsh, M.T., Beusse, D., Bossart, G.D., Young, W.G., Odell, D.K. & Patton, G.W. (1988) Ray encounters as a mortality factor in Atlantic bottlenose dolphins (*Tursiops truncatus*). *Marine Mammal Science*, **4**, 154-162.
- Wang, J., Chou, L. & White, B. (2000) Differences in the external morphology of two sympatric species of bottlenose dolphins (genus *Tursiops*) in the waters of China. *Journal of Mammalogy*, **81**, 1157-1165.
- Watkins, W.A., Daher, M.A., Fristrup, K. & Notarbartolo Di Sciara, G. (1994) Fishing and acoustic behavior of Fraser's dolphin (*Lagenodelphis hosei*) near Dominica, southeast Caribbean. *Caribbean Journal of Science*, **30**, 76-82.
- Weinrich, M.T., Belt, C.R. & Morin, D. (2001) Behavior and ecology of the Atlantic white-sided dolphin (*Lagenorhynchus acutus*) in coastal New England waters. *Marine Mammal Science*, **17**, 231-248.
- Weir, C.R. (2006) First confirmed records of Clymene dolphin, *Stenella clymene* (Gray, 1850), from Angola and Congo, south-east Atlantic Ocean. *African Zoology*, **41**, 297.
- Weir, C.R. (2010) A review of cetacean occurrence in West African waters from the Gulf of Guinea to Angola. *Mammal Review*, **40**, 2-39.
- Weir, C.R., Goncalves, L. & May, D. (2013) New Gulf of Guinea (Africa) range state records for pygmy killer whale (*Feresa attenuata*) and Fraser's dolphin (*Lagenodelphis hosei*). *Marine Biodiversity Records*, **6**, e35.
- Weller, D.W., Cockcroft, V.G., Würsig, B., Lynn, S.K. & Fertl, D. (1997) Behavioral responses of bottlenose dolphins to remote biopsy sampling and observations of surgical biopsy wound healing.
- Wickert, J.C. (2013) Tursiops no Oceano Atlântico Sul Ocidental: redescricao e revalidação de *Tursiops geophysus* Lahille, 1908 (Cetartiodactyla: Delphinidae). Master Thesis Universidade Federal do Rio Grande do Sul, Porto Alegre.
- Worthy, G., Casper, D., Rhinehart, H. & Moser, M. (1993) First record of live-stranded pantropical spotted dolphin (*Stenella attenuata graffmani*) in Central California, USA. *Marine Mammal Science*, **9**, 316-319.
- Ximenez, A. & Praderi, R. (1992) Nuevos aportes sobre el conocimiento de delfines del género *Stenella* para el Atlántico sudoccidental. *Anales 3ra Reunión de Trabajo de Especialistas en Mamíferos Acuáticos de América del Sur. CIMMA, Montevideo*, 72-79.

ANEXO 2

Normas ao Autor do periódico *Journal of Biogeography*

Disponível em: [http://onlinelibrary.wiley.com/journal/10.1111/\(ISSN\)1365-2699/homepage/ForAuthors.html](http://onlinelibrary.wiley.com/journal/10.1111/(ISSN)1365-2699/homepage/ForAuthors.html)

Instructions for Authors

Papers dealing with all aspects of spatial, ecological and historical biogeography are considered for publication in the *Journal of Biogeography*. The mission of the Journal is to contribute to the growth and societal relevance of the discipline of biogeography through its role in the dissemination of biogeographical research. To that end, the editorial policy is that the Journal seeks to be representative of the discipline of biogeography, to be global in scope, and to be inclusive of major traditions and viewpoints in the discipline. Authors are particularly encouraged to submit concise, clearly written papers focused on precisely framed questions or hypotheses of broad interest to the wide international readership of the Journal. The Journal was established in 1974 and is published in 12 issues a year.

Original Articles

Standard research papers are classed as Original Articles. Authors should prepare their manuscript so that, when published, the article will comprise not more than 10 to 12 published pages. A single page of the journal can carry one of the following: (1) the article title, author list, abstract, and keywords; (2) about 1000 words of text (including subheadings); (3) about 30 references. For a typical Original Article, in which illustrative material (Tables and Figures) occupies about 3 pages of the journal when printed at final journal sizing, the text, inclusive of abstract and reference list, should not exceed 7000 words. **The word count, inclusive of abstract, main text and references, should be stated on p1 of the manuscript.**

Manuscripts should be presented in the following order: title page, giving the article type: Original Article, the article title, author names, author research addresses, correspondence author's name, address and e-mail, and short running head (maximum of 8 words); a structured abstract (as detailed below); 6–10 keywords (in alphabetical order); main text; references (using the standard referencing system of the journal); biosketch (see below); tables with their legends above; list of figure legends; and embedded figures. The main headers for Original Articles should normally be Introduction, Materials and Methods, Results, Discussion, Acknowledgements, References.

References

Authors must use the system illustrated below. Unpublished data, works in preparation and papers submitted but not yet accepted may be cited in the text, giving the author's initials and surname, but should not be included in the reference list. It is the author's responsibility to obtain permission from colleagues to include their work as a personal communication. Please add the person's initials, surname and institute for personal communications.

In the text, references should be made by giving the author's name with the year of publication, as follows: (Bush & Rivera, 1998). When reference is made to a work by three or more authors the first name followed by *et al.*, is used on all occasions. If several papers by the same author and from the same year are cited, a, b, c, etc. should be put after the year of publication, as follows (Schoener & Schoener, 1983a,b). When citing a list of papers, place them in date order (alphabetically when within a year) and separate them with semi-colons as follows (Schoener & Schoener, 1983a,b; Bush & Rivera, 1998, 2003; Collins, 1998, 2002; Whittaker *et al.*, 2007).

In the list, references should be sorted alphabetically by first author, then by number of authors (one, two, three or more), then chronologically within the one-author group, alphabetically within the two-author group, and chronologically within the \geq three-author group. For multi-authored works with more than 20 authors, list only the first three authors followed by *et al.* Page extents of single-volume works are not required. **Titles of journals should be given in full.** Check the Journal for reference style. Some examples are given below:

Prentice, I.C., Guiot, J., Huntley, B., Jolly, D. & Cheddadi, R. (1996) Reconstructing biomes from palaeoecological data; a general method and its application to European pollen data at 0 and 6 ka. *Climate Dynamics*, **12**, 185-194.

Cox, C. B. & Moore, P. D. (1999) *Biogeography: an ecological and evolutionary approach*, 6th edn. Blackwell Science Ltd, Oxford.

Guo, Q. (1994) *Dynamic desert Puccinellia maritima plant community ecology: changes in space and time*. PhD Thesis, University of New Mexico, Albuquerque.

May, R.M. (1994) The effects of spatial scale on ecological questions and answers. *Large-scale ecology and conservation biology* (ed. by P.J. Edwards, R.M. May and N.R. Webb), pp. 1-17. Blackwell Scientific Publications, Oxford.

StatSoft Inc. (2003) *STATISTICA (data analysis software system), version 6.1*. StatSoft, Inc., Tulsa, OK.

