



UNIVERSIDADE FEDERAL DO RIO GRANDE DO SUL  
Seminário do Programa de Pós-Graduação em Engenharia Química  
Oktober Fórum 2005 – PPGEQ



10 anos

**INDUSTRIAL APPLICATION OF A NEW CONTROL LOOP PERFORMANCE  
ASSESSMENT TOOL**

Ariel Kempf<sup>1</sup>, Leandro P. Lusa<sup>1</sup>, Luís G. S. Longhi<sup>2</sup>, Jorge O. Trierweiler<sup>3</sup>, Argimiro R. Secchi<sup>3</sup>, Herbert  
Teixeira<sup>4</sup>, Euclides A. Neto<sup>5</sup>

<sup>1</sup>TriSolutions Soluções em Engenharia / GIMSCOP  
Departamento de Engenharia Química, Universidade Federal do Rio Grande do Sul (UFRGS)  
R. Eng. Luis Englert, s/n. Campus Central. CEP: 90040-040 - Porto Alegre - RS - BRASIL,  
E-MAIL: ariel@enq.ufrgs.br

<sup>2</sup>Alberto Pasqualini - REFAP S/A

<sup>3</sup>Departamento de Engenharia Química – Universidade Federal do Rio Grande do Sul

<sup>4</sup>CENPES – Petrobrás S/A.

<sup>5</sup>Petrobrás S.A.

**Palavras Chaves:** Control loop performance assessment, crude distillation unit, software development, process monitoring.

**Resumo:** Control loop performance assessment (CLPA) procedures are more and more attracting the industry's attention. The benefits of employing such techniques are evident: products with lower variability and increased quality, better use of energy and raw-materials, better use of engineering crew, improved maintenance process (through predictive maintenance) and so on, all resulting in increased revenue with reduction of costs. Although the techniques are very well established, a few tools for assessing performance are available, all of them developed out of South America, with high costs and lack of technical support. On the other hand, Brazilian industry is awaking for the necessity of using such tools due to increased competitiveness in the market. In this context, a Brazilian company, sponsored by the biggest oil company in Brazil, developed a simple software application that provides the most meaningful techniques for CLPA. This software, called TriPerfX, is integrated to Excel® and features minimum variance based techniques (for single loops, recursive calculation and cascade loops), oscillation detection procedures, spectral analysis, closed-loop finite impulse response, autocorrelation and, cross correlation functions. These tools, integrated to Excel's classical statistic tools and data management resources, allow engineers to create complete and detailed performance assessment reports of large plants. In this work, a comprehensive application of TriPerfX is made to an atmospheric distillation column of a petroleum refinery. The details of each individual index are briefly described; the methodology for using the various CLPA procedures is presented and results are reported, together with diagnosis of problematic loops. Finally, the results are statistically ordered and displayed to provide significant global information of the set of control loops analyzed. The results of this application show the importance of software like TriPerfX and motivate further increase of the tool's features, specially an on-line automated implementation.

## 1 INTRODUCTION

Control loop performance assessment (CLPA) techniques are a well-established issue. Several classic statistical methods were always available and were employed to assert the quality of continuous productive processes, which is the goal of Statistic Process Control. The assessment of control loops, more specifically, started to gain

attention when Harris (1989) showed that is possible to estimate the minimum variance of a feedback controller with simple routine process data and the a priori knowledge of time delay. The minimum variance (MV) is the optimal variance produced by a minimum variance controller (MVC). It is minimum in the sense that no other linear feedback controller can achieve smaller variance. Desborough and Harris (1992) came up



## Oktober Fórum 2005 – PPGEQ

with the idea of quantifying the performance of such regulatory controllers using MV as benchmark, yielding an index to measure the potential of reduction of the produced variance.

Since then, several developments were made, and the academic productivity is still very active. Harris et al. (1996a) extended the MV based technique to multivariate control loops; Huang and Shah (1996) proposed a new way to estimate MV using filtering and correlation (FCOR method), which was also extended to multivariate loops, with a much more practical appeal by use of interactor matrices, as found in Huang et al. (1996) and Huang et al. (1997); Ko and Edgar (2000) proposed a MV based method to estimate performance index of cascade controllers; feedforward controllers are explored by Desborough and Harris (1993) and Huang et al. (2000); MPC performance assessment is addressed by Patwardhan and Shah (2002), Ko and Edgar (2001) and Schäfer and Cinar (2004); among other proposals and approaches. Comprehensive reviews on the subject are available by Harris et al. (1999), Kempf (2003) and Qin (1998). Recently, the issue of knowing the a priori time delay is being addressed by Huang et al. (2005).

Parallel to the MV approach, other techniques has been developed or employed to complement the assessment of control loops. Oscillation detection procedures as proposed by Häggglund (1995, 2002), spectral analysis, autocorrelation functions, cross-correlation functions, simple statistics and metrics like valve travel and valve reversals are frequently used to monitor and diagnose control loops.

Practical applications are also reported in literature, as found in Harris et al (1996b), Huang and Shah (1998), Thornhill et al. (1999) and Paulonis and Cox (2003). Around 1997, the market started to produce software to perform the task of analyze and assess control loops.

Brazilian industry is now awaking to the necessity of having such assessment procedures and benefiting of the inherent gains. This makes the country very attractive to companies that develop software within this area. In this context, an application was developed by a Brazilian company, sponsored by the its biggest national oil company and with support from the Federal University of Rio Grande do Sul (UFRGS). With this tool, one is able to run the most meaningful procedures for CLPA and generate reports that enable the user to choose the priorities to act in advance or to correct actual issues, taking operational and financial benefits from predictive maintenance policy.

This tool, formerly named TriPerfX, is integrated to Excel, one of the most powerful and used

application in industry. TriPerfX was applied to a crude distillation unit (CDU) of a petroleum refinery and the results are discussed here. The paper starts describing briefly the studied area of the refinery, the methods used to assess performance and the developed tool. It finishes with a presentation and discussion of some results.

## 2 PLANT DESCRIPTION

The studied section is part of the Distillation Unit 50 (U-50) of the Refinery Alberto Pasqualini (REFAP). This section is composed by two atmospheric furnaces in parallel operation (F-5001A and F-5001B), heating and partially vaporizing the oil load, which is fed in the lower section of the atmospheric distillation tower (T-5001).

This distillation tower does not have a bottom reboiler, having only a flash vapor injection at the bottom. The condensation system is composed by eight condensers that use cold water and a condensation drum. Three streams leave the top drum, one of vapor, composed by not condensable components which are thrown to the refinery's gas system, another of liquid, which is the top reflux of the column and the third one is liquid, known as non-stabilized light naphtha (NLNE), which is the top product.

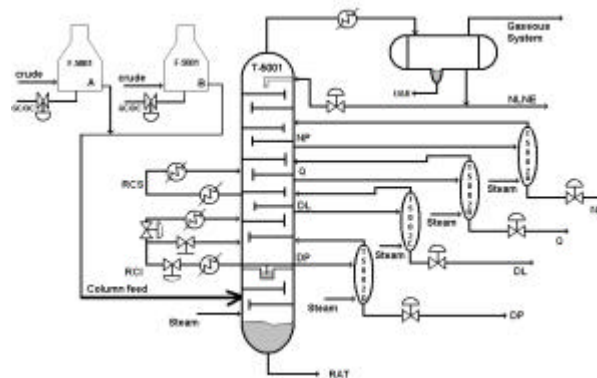

Fig. 1. Schematic diagram of the studied part of REFAP's T-5001 CDU.

The column has also other four streams leaving from its side. These streams are named as heavy naphtha (NP), kerosene (Q), light diesel (DL) and heavy diesel (DP). Each of these four streams passes through an extra rectification column. The main column's bottom product is called atmospheric residue (RAT). In addition to the product streams, the column has also two cycling



## Oktober Fórum 2005 – PPGEQ

refluxes (pumparounds): in the upper zone (RCS) and, in the lower zone (RCI). These refluxes are used to heat other process streams, representing loops of energetic integration with other process sections. A graphical illustration showing the studied section of T-5001 crude distillation unit is presented in Figure 1.

### 3 PERFORMANCE ASSESSMENT

This section describes briefly the tool used to assess control loops, the methods employed to analyze performance and some practical considerations brought up during the application.

#### 3.1. TriPerfX

TriPerfX, in the version applied in this paper, is written as an add-in to Excel®. The reasons for choosing the integration to the Microsoft's spreadsheet are clear: Excel is the most popular tool among process engineers in industry, in a way that every engineer is familiar with its intuitive graphical user interface, the power of handling data sets, the thousands of functions available, the integration with data acquisition systems, the possibility of customization through use of macros, the easy and flexible report generation and the additional statistic tools available.

TriPerfX comes to add more power to Excel and to bring to its interface, some CLPA tools, allowing engineers in industry to transform raw process data in relevant information to aid in optimization, maintenance and production increase, with consequent improvement in receipts. Allied with the powerful Excel's classical statistic tools, one can generate complete reports with meaningful data about control loops performance.

TriPerfX starts by creating a new menu in Excel's menu bar, where one can access all the tools of the add-in. Each menu item presents a dialog where the user can enter the necessary data to perform calculations. All the calculations are made through formulas that the dialog can automate for the user. If it is desired, one can enter directly the formulas in cells or use the Excel's Function Wizard tool. The access to the functions can also be made through macros written in VBA, expanding the automation possibilities for results generation.

The functions available are indexes based on MVC, which can be calculated in several ways, auto- and cross-correlation functions, an oscillation detection procedure, low-pass data filters and spectral analysis. For sake of efficiency, all code was written and compiled in C++, instead of the commonly used Visual Basic for such add-ins.

These tools, combined with Excel's well-known features, allows one to include even more performance metrics in a worksheet, increasing the useful information content, as described in the following section.

#### 3.2. Applied Methods

For the application of TriPerfX to the CDU data, a custom workbook was previously developed. This workbook was organized in a way to make easier the report generation and the automation of the calculation tasks and data acquisition. The workbook was divided in worksheets, one for each loop. In every worksheet, all the information about the loop is gathered from the refinery's information system (in this case, OSI's PI Add-In for Excel). The necessary parameters for performance calculations were manually entered. In addition to the metrics provided by the add-in, other useful performance measures were included in the worksheets. The methods employed are briefly described below.

**MVC based index.** It is an index that measures the potential of performance improvement of a loop in terms of variance reduction. The index is obtained basically by the ratio between the variance produced by a hypothetical MVC applied to the loop and the actual loop controller variance. The index is comprised in the range from 0 to 1, where zero indicates optimal performance (no variability reduction potential) and values near the unity indicate absence of control.

**Spectral/temporal analysis.** It is the analysis of the existence of oscillatory components in a signal. Peaks in a graphic of spectral/temporal analysis indicate the frequencies/periods in which oscillation occurs. The spectrum is obtained by the processing of the variable's signal by a Fast Fourier Transform (FFT). The spectrum produces results in frequency domain and can be converted to time domain (temporal analysis), where the results indicate oscillation periods in time units.

**Autocorrelation Function (ACF).** A natural occurring phenomena, when sampled, results in a data set in which a certain point is strongly dependent from previously collected points, that's to say, the state of the system is defined in great part by its past. The sampled signal of this system in free evolution results greatly correlated. The role of a controller is to act over the system in a way to prevent the process from taking its natural tendency and keeping at setpoint. The signal over action of a well-tuned controller results not correlated. The ACF presents the correlation that a certain point of the sample has regarding to points previously



## Oktober Fórum 2005 – PPGEQ

sampled. As the time delay vanishes, period in which the controller cannot act, the ACF must be eliminated to characterize good control.

**Cross-correlation function (XCF).** Similar to the ACF idea. The XCF shows the dependence that one variable has in relation to other variable's current value and their past values. It can show interdependent oscillatory behavior or interaction between variables.

**Oscillation detection procedure.** Method based on the work of Hägglund (1995). This technique uses IAE and loop dynamic information to recursively count disturbances and decide whether an occurring disturbance is an oscillation or a normal disturbance.

**Disturbance amplification factor.** Technique applied only to surge level loops. This factor is given by the ratio between the summation of the controller output (in %) and the IAE of the process variable (converted to %, if necessary, using the PV range). A value greater than one indicate that the surge level loop is not reducing disturbances at vase input, while values smaller than one indicate that the vase is absorbing disturbances.

**Traditional statistics.** Classic statistics like mean, variance, standard deviation, percentile error and operational measures like percentile of time in manual operation or percentile of time in saturated condition were also used in the worksheets and add value to the loop's diagnose.

**Graphical analysis.** Plots of the process variable (PV) and the setpoint (SP) were displayed in the same figure, while plots of the control action (valve position, OP, usually in percentage units) were plotted apart. Diagrams plotting PV versus OP were built and are useful to detect extreme hysteresis, valve stiction or other abnormal valve functioning. The spectral/temporal analysis and the ACF and XCF were also plotted in the worksheets.

### 3.3 Practical Considerations

During the performance assessment of the refinery data, some practical issues arose, mainly regarding to data compression and parameters configuration.

**Data Compression.** As the version of TriPerfX employed on the study was not on-line, historical data must be acquired. Despite the PI's compression configuration in the refinery be appropriated for typical industry analysis, it is not adequate for performance assessment studies with historical data for some fast loops. Figure 2 shows an example of compression effects on a flow loop. That makes impossible to assess performance using MVC based techniques. On the other hand, tests showed that the

compression applied to temperature loops was satisfactory, not changing the performance index results. For the purpose of this study, the compression was turned off for flow, pressure and level loops during the period necessary to acquire sufficient uncompressed data for performance assessment.

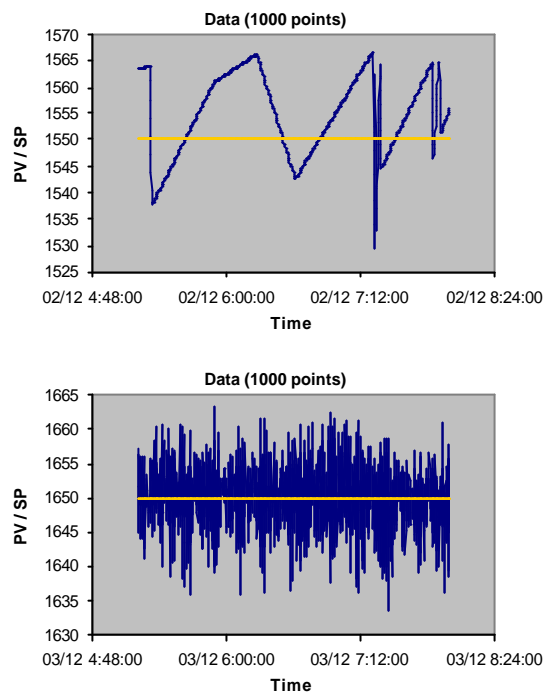

**Fig. 2.** Data with compression on (up) presenting a MVC index of 0,998, and with compression turned off (down), presenting an index of 0,316 for the same loop.

An on-line version of the tool would be free of the compression issue, as well as filtering, exception and other interference.

**Sampling Time and Sample Size.** Data was collected with a sampling time of about 8 seconds. For some fast loops, this frequency is still not the ideal one, but that is the limitation of the refinery data acquisition system due to network devices, traffic, etc. To find a good balance between statistical properties, proper dynamic description and performance characterization, a sample size of 1000 points was collected.

**Index Parameters.** The main parameter to estimate MVC based performance index is the loop's time delay. Recommendations for default values in refineries can be found in Thornhill et al. (1999). Despite these default values, using historical data can be an opportunity to find set-point changes,



# Oktober Fórum 2005 – PPGEQ

## 4 RESULTS AND DISCUSSION

allowing the user to infer the time delay. When available, that was used to define this value. The order of autoregressive models for minimum variance estimation was fixed in 15. The parameters necessary to the oscillation detection procedure according to Hägglund (1995) were set based on a "typical dynamic" behavior of different classes of control loops, e.g., flow, temperature, pressure and level, following recommendations also found in Hägglund (1995).

A total of 36 control loops was analyzed in the referred refinery area: 7 are level loops, 8 pressure loops, 18 flow loops and 3 temperature loops. Every loop performance assessment result is showed in one worksheet, like illustrated schematically by Figure 3.

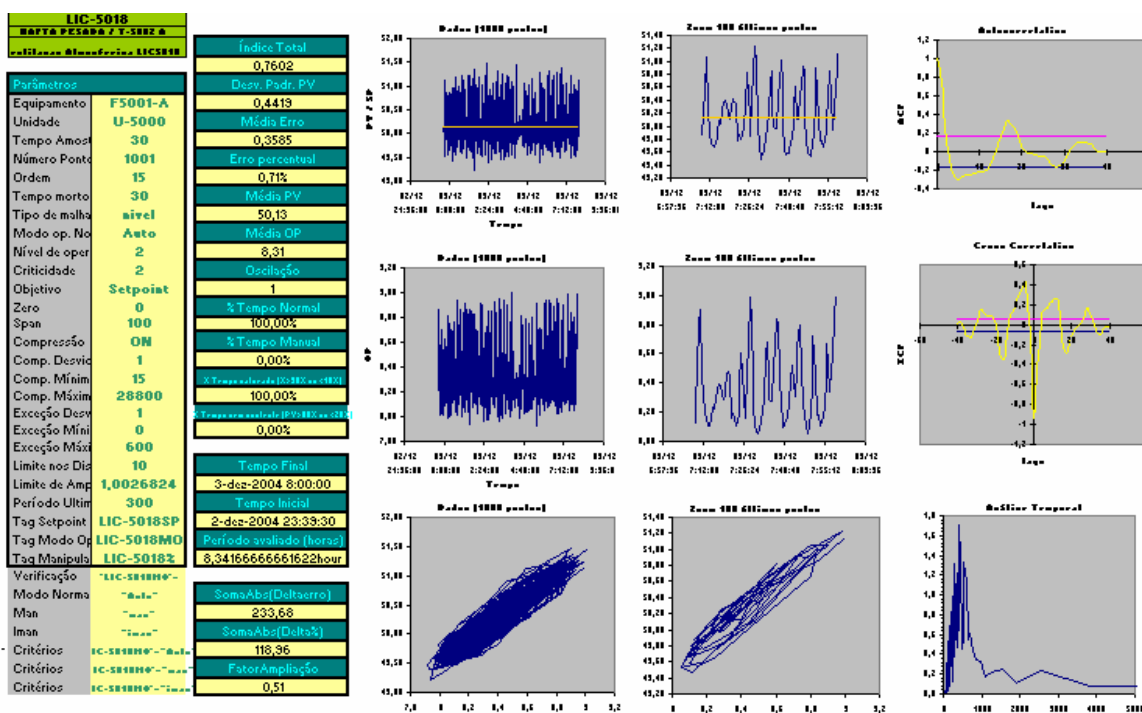

Fig. 3. Schema of a worksheet with results of one control loop.

The left two columns in Figure 3 are composed, basically, of input and some descriptive data. The next column presents the numerical values for the computed indexes. The graphical analysis is placed from the center to the right edge. During inspection of the generated results, some interesting cases were found. For instance, the oscillation detection procedure pointed high oscillation rate in a flow loop named FIC-5017. This result, as well as a MVC index of 0.9, led to a more careful inspection of the loop situation. The diagram plotting PV versus OP indicated strange

behavior, similar to stiction in valve. Figure 4 shows the process data sample of both PV and OP, while Figure 5 shows the PV x OP diagram, where the stiction behavior is evidenced, together with the spectral analysis converted to time domain, showing a strong peak at 150s, which is exactly the period of the PV and OP oscillation cycle. This analysis as well as the other loops situation was submitted to the refinery's managers in order to help them to organize the priority choices for their maintaining and optimization tasks.



# Oktober Fórum 2005 – PPGEQ

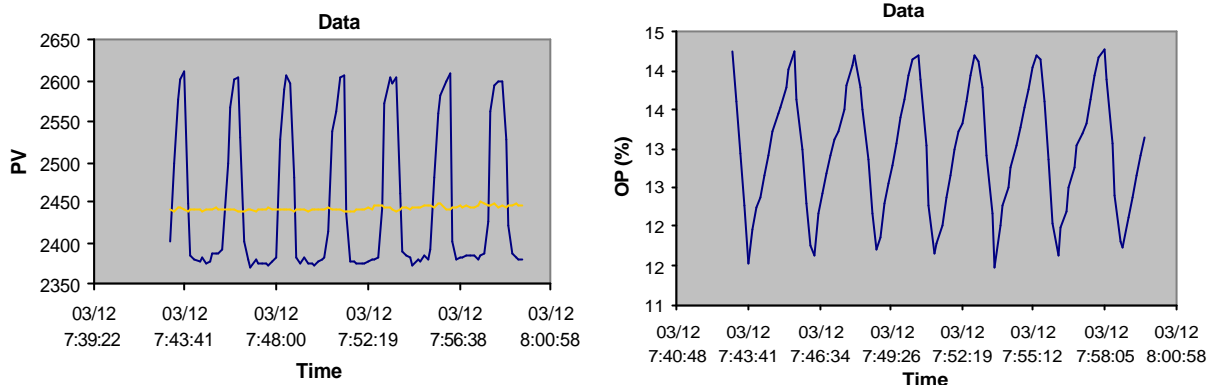

Fig. 4. PV / Setpoint (left) and valve behavior (OP, right) for FIC-5017.

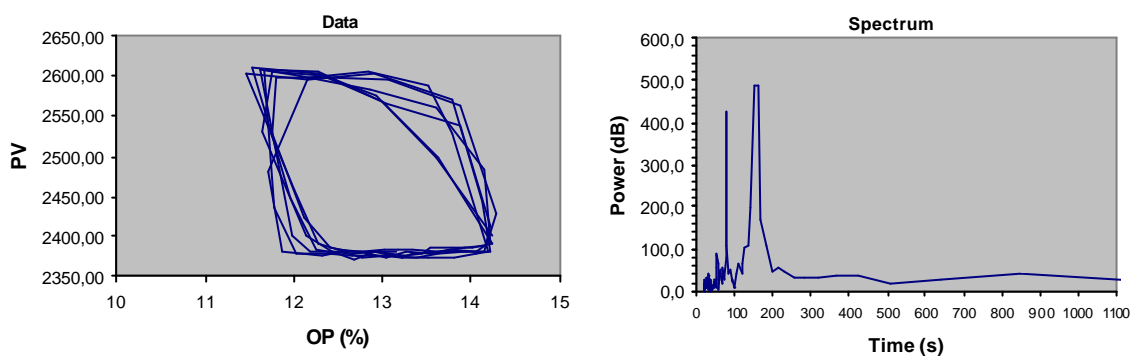

Fig. 5. PV x OP diagram for FIC-5017 showing the squared behavior typical of valve stiction (left) and the correspondent spectra (right).

All the results obtained were sorted in another workbook to better analyze and compare the various numerical indexes. The sorted categories were, among others, the type of loop, the physical unit which they belong to, the MVC based index, oscillation detection and disturbance amplification factor (for levels). Table 1 shows a sample of a worksheet with results sorted according to MVC index for flow loops.

Of the 36 loops analyzed, only 2 (flow loops) were not operating (manual mode) and other 2 (level loops) were presenting periods of saturation. Table 2 shows the main results for level loops. According to the disturbance amplification factor, almost half of them could be readjusted to improve their performance.

Another feature of TriPerfX that helps its users is ranking the loops. Table 3 shows the top 10 worse loops (excluded level loops) classified by the minimum variance index. Temperature loops normally are loosely tuned and frequently present

“poor” performance when assessed by the MVC criteria. Flow and pressure loops with indexes at this level almost certainly need to be retuned.

During the results analysis, at least one control strategy change was proposed. A cascade loop consisting of a flow loop (primary) and a pressure loop (secondary) was presenting a potential for performance improvement. It is a common sense that the secondary loop must be at least ten times faster than the primary for a good tuning (Åström and Hägglund, 1998). That was not the case in this flow/pressure cascade. It is suggested to remove the flow loop leaving a single pressure loop. An alternative to attain a better performance would be to tune the flow loop to become slower than the pressure loop.

Based on the results of the performance assessment, a detailed report was prepared and sent to the engineers responsible for the refinery-side of the study. The report included comments about performance of every loop and some



# Oktober Fórum 2005 – PPGEQ

recommendations about loop tuning or control strategy changes.

**Table 1.** Sample table of results for flow loops sorted by decreasing MVC index.

Area	Loop Type	Name	MVC Index	Std. Dev.	Mean Error	Error %	Mean PV	Osc.	Time Satur.	Time Manual
T50001 Top	Flow	FIC-5017	0,900	101,438	77,18	3,16%	2443,6	12	0,00%	0,00%
T50001 Side	Flow	FIC-5025	0,894	36,264	28,07	2,67%	1050,4	5	0,00%	0,00%
T50001 Side	Flow	FIC-5019	0,869	13,272	11,45	0,55%	2099,7	0	0,00%	0,00%
F-5001B	Flow	FIC-5056	0,851	0,219	0,13	6,69%	1,96	5	0,00%	0,00%
T50001 Bottom	Flow	FIC-5024	0,814	49,062	7,58	0,45%	1700,9	0	0,00%	0,00%
F-5001B	Flow	FIC-5058	0,766	6,828	6,10	0,47%	1300,1	0	0,00%	0,00%
T50001 Top	Flow	FIC-5018	0,644	80,061	23,79	0,31%	7756,9	0	0,00%	0,00%
T50001 Side	Flow	FIC-5026	0,594	31,442	25,34	2,11%	1200,0	13	0,00%	0,00%
T50001 Side	Flow	FIC-5031	0,507	44,862	36,78	0,25%	14600,2	0	0,00%	0,00%
T50001 Top	Flow	FIC-5114	0,343	59,080	8,57	0,37%	2308,1	0	0,00%	0,00%
F-5001A	Flow	FIC-5057	0,313	4,970	3,98	0,24%	1649,9	0	0,00%	0,00%
T50001 Side	Flow	FIC-5028	0,216	33,889	1,30	0,05%	2591,6	0	100,00%	100,00%
T50001 Side	Flow	FIC-5029	0,101	32,755	25,62	0,28%	9260,2	0	0,00%	0,00%
T50001 Side	Flow	FIC-5027	0,012	12,395	1,27	0,04%	3390,3	0	100,00%	100,00%

**Table 2.** Table with results for all level loops analyzed, sorted by the disturbance amplification factor.

Area	Loop Type	Name	Std. Dev.	Mean Error	Error %	Mean PV	Amplif. Factor	Osc.	Time Satur.	Time Manual
T50001 Top	Level	LIC-5008	0,720	0,57	1,09%	51,86	1,53	2	0,00%	0,00%
T50001 Top	Level	LIC-5014	0,979	0,77	1,57%	49,00	1,19	0	0,00%	0,00%
T50001 Bottom	Level	LIC-5027	0,325	0,26	0,58%	44,99	1,16	0	0,00%	0,00%
T50001 Side	Level	LIC-5022	0,591	0,50	1,00%	50,01	0,58	0	0,00%	0,00%
T50001 Side	Level	LIC-5018	0,442	0,36	0,71%	50,13	0,51	1	100,00%	0,00%
T50001 Side	Level	LIC-5020	0,589	0,46	0,70%	64,99	0,42	0	32,63%	0,00%
T50001 Side	Level	LIC-5024	0,560	0,48	0,96%	50,00	0,24	0	0,00%	0,00%

**Table 3.** Top 10 worse loops, ranked according to the minimum variance based index.

Area	Loop Type	Name	MVC Index
F-5001B	Pressure	PIC-5094	0,986
F-5001B	Temperature	TIC-5011	0,932
T50001 Top	Pressure	PIC-5027	0,930
F-5001A	Temperature	TIC-5010	0,920
T50001 Top	Flow	FIC-5017	0,900
T50001 Side	Flow	FIC-5025	0,894
T50001 Side	Flow	FIC-5019	0,869
F-5001B	Pressure	PIC-5223	0,857
F-5001B	Flow	FIC-5056	0,851
T50001 Bottom	Flow	FIC-5024	0,814

## 5 CONCLUSION

The results of the performance assessment procedure applied for this study showed the importance of using such tool in industry. The study pointed out which loops should be retuned, which valves should be changed/fixed and suggested control strategy changes for improved operation.

The main difficulties found in the practical use of TriPerfX point to the implementation of an on-line solution, which is being carried on. The off-line tool can be used from times to times to monitor performance and does its job very well. If it is desired the assessment in a more automated fashion, an on-line tool is ideal. Such implementation has advantages of not facing data compression problems, less human interference and



## Oktober Fórum 2005 – PPGEQ

the capacity of dealing with a larger number of loops.

Anyway, the benefits of using such tool are clear. From the maintenance side, one can easily see the critical control units to be approached first and, in a periodic monitoring, the performance degradation ranking can alert maintenance team to act before failures. For the engineering side, one can find opportunities for process optimization through best loop tuning or control strategies changes, as well as it helps to have a better understanding of the process. For the overall company the benefits come in the form of an increase in revenue due to improved operation, better use of raw-materials and better environment and safety operation conditions.

### ACKNOWLEDGEMENTS

To the team of engineers of TriSoluções Soluções em Engenharia and of Petrobras S. A. (CENPES and REFAP), for making this research possible and also to the professors at the Universidade Federal do Rio Grande do Sul (UFRGS) Dept. Chemical Engineering for the knowledge shared.

### REFERÊNCIAS

ÅSTRÖM, K. J., HÄGGLUND, T. (1998). PID Controllers: Theory, Design and Tuning”, 2nd Edition, Instrument Society of America.

DESBOROUGH, L., HARRIS, T. J. (1992). Performance Assessment Measures for Univariate Feedback Control. The Canadian Journal of Chemical Engineering, 70, 1186-1197.

DESBOROUGH, L., HARRIS, T. J. (1993). Performance Assessment Measures for Univariate Feedforward/Feedback Control. The Canadian Journal of Chemical Engineering, 71, 605-616.

HÄGGLUND, T (1995). A Control Loop Performance Monitor. Control Eng. Practice, 3, 1543-1551.

HÄGGLUND, T (2002). Industrial Application of Automatic Monitoring Tools. Control Eng. Practice, Proceed. 15th IFAC.

HARRIS, T. J. (1989). Assessment of Control Loop Performance, The Canadian Journal of Chem. Engineering, 67, 856-861.

HARRIS, T. J., BOUDREAU, F., MACGREGOR, J. (1996a). Performance Assessment of Multivariable Feedback Controllers, Automatica, 32, 1505-1518.

HARRIS, T. J., SEPPALA, C. T., JOFRIET, P. J., SURGENOR, B. W. (1996b). Plant-Wide Feedback Control Performance Assessment Using an Expert-System Framework. Control Eng. Practice, 4, 1297-1303.

HARRIS, T. J., SEPPALA, C. T., DESBOROUGH, L. D. (1999). A review of performance monitoring and assessment techniques for univariate and multivariate control systems. Journal of Process Control, 9, 1-17.

HUANG, B., SHAH, S. L. (1996). Performance limits: practical control loop performance assessment. Proceed. of AIChE Annual Meeting. Huang, B., Shah, S. L., Kwok, K. (1996). How good is your controller? Application of control loop performance assessment techniques to MIMO processes. Proceed. 13th IFAC World Congress, Vol. M, 229-239.

HUANG, B., SHAH, S. L., FUJII, H. (1997). The unitary matrix and its estimation using closed loop data. Journal of Process Control, 7, 195-207. Huang, B. Shah, S. L., (1998). Practical Issues in Multivariable Feedback Control Performance Assessment. Journal of Process Control, 8, 421-430.

HUANG, B., SHAH, S. L., MILLER, R. (2000). Feedforward Plus Feedback Controller Performance Assessment of MIMO Systems, IEEE Trans. on Control Systems Technology, 8, 580-587.

HUANG, B., DING, S. X., THORNHILL, N. (2005). Practical solution to multivariate feedback control performance assessment problem: reduced a priori knowledge of interactor matrices. Journal of Process Control, 15, 573-583.

KEMPF, A. O., (2003). Avaliação de Desempenho de Malhas de Controle. M. Sc. Thesis. DEQUI – UFRGS.

KO, B. S., EDGAR, T. F. (2000). Performance Assessment of Cascade Control Loops. AIChE Journal. 46, 281-291.

KO, B. S., EDGAR, T. F. (2001). Performance Assessment of Constrained Model Predictive





10 anos

Control Systems. Process Systems Engineering –  
Aiche Journal. 49, 6.

PATWARDHAN, R. S., SHAH, S. L., (2002).  
Issues in performance diagnostics of model-based  
controllers. Journal of Process Control, 12, 413-  
427.

PAULONIS, M. A., COX, J. W. (2003). A practical  
approach for large-scale controller performance  
assessment, diagnosis and improvement. Journal of  
Process Control, 13, 155-168.

QIN, S. J. (1998). Control Performance Monitoring  
– a review and assessment. Computers and Chem.  
Eng. 23, 173-186.

SCHÄFER, J., CINAR, A. (2004). Multivariable  
MPC system performance assessment, monitoring  
and diagnosis. Journal of Process Control, 14.

THORNHILL, N. F., OETTINGER, M.,  
FEDENKZUK, P. (1999) Refinery-wide control  
loop performance assessment. Journal of Process  
Control, 9, 109-124.