

## STEPPED SPILLWAY FLOW: PRE-AERATION WITH DEFLECTOR

MARCELO G. MARQUES<sup>(1)</sup>, RUTE FERLA<sup>(2)</sup>, CAROLINA K. NOVAKOSKI<sup>(3)</sup>, MAURICIO DAI PRÁ<sup>(4)</sup>, EDER D. TEIXEIRA<sup>(5)</sup>, LUIZ A. M. ENDRES<sup>(6)</sup>, ALEXANDRE C. PRESTES<sup>(7)</sup>, PEDRO J. MORAES<sup>(8)</sup>, ANGELO F. RIGO<sup>(9)</sup>, ALBA V. B. CANELLAS<sup>(10)</sup>

<sup>(1-9)</sup> Instituto de Pesquisas Hidráulicas (IPH/UFRGS), Porto Alegre, Brazil,  
mmarques@iph.ufrgs.br, carolkn04@gmail.com, mauricio.daipra@ufrgs.br, eder.teixeira@ufrgs.br, endres@ufrgs.br,  
alexandrecastraprestes@gmail.com, pedrojmoraeess@gmail.com, angelo.rigo@ufrgs.br

<sup>(10)</sup> Furnas Centrais Elétricas, Rio de Janeiro, Brazil, alba@furnas.com.br

### ABSTRACT

During floods, stepped spillways have the purpose of dissipating energy over the flow passage through the chute, minimizing stilling basins dimensions. However, stepped spillways have their utilization frequently limited to unit discharges of approximately 15 m<sup>3</sup>/s/m, due to the risk of cavitation damage. In order to increase the specific yields endured by these structures avoiding cavitation damages, some aeration elements are being studied. These elements allow a jet formation and the air can be introduced through the lower portion, in addition to the surface aeration. The present paper has the purpose of analyze the medium pressures behavior and the jet formation in a flow over stepped spillway through measures conducted on a scale reduced physical model. It was possible to notice that the jet reaches the 7<sup>th</sup> step for the higher flows and the 9<sup>th</sup> step for the lower. Furthermore, it was observed that, upstream of the jet impact location, the mean pressures were close to zero. These pressures were lower than the same measured at a stepped chute with natural aeration (without aerator elements) for the horizontal faces of the steps and higher for the vertical faces of the steps. Near the jet's impact location, for both faces of the steps, a peak of positive pressures was observed, exceeding the same values on a chute with natural aeration. Downstream of this location, the pressures tend to the values acquired with natural aeration.

**Keywords:** Stepped spillways, induced aeration, deflector.

### 1 INTRODUCTION

Spillways are hydraulic protection structures in dams and associated structures, allowing the excess of water in a reservoir of a hydraulic work to be returned to the river safely. Particularly, stepped spillways are characterized by providing additional energy dissipation, and, therefore, minimizing stilling basins dimensions. Due to the advantages of energy dissipation and construction facility, these structures have been utilized on a broad scale in the entire world since the decade of 1970. However, stepped spillways have their utilization frequently limited to unit discharges of approximately 15 m<sup>3</sup>/s/m (GOMES, 2006; AMADOR et al., 2009; OSMAR, 2016; NOVAKOSKI et al., 2018), due to the risk of cavitation damage. There is an increasing interest in maximizing the unit discharge able to flow over a stepped chute without risks of cavitation damage. Therefore, the care with the consequences of cavitation in stepped spillways is increasing by the fact that the structures are being designed and submitted to higher specific yields (DAI PRÁ, 2004).

Peterka (1953) provided quantitative information regarding the possibility of reducing cavitation erosion in concrete structures through flow aeration. The introduction of air into the flow is a measure already disseminated in smooth spillways for the protection of concrete in areas prone to cavitation. However, the alternative of inserting aerator elements stepped spillways is recent. There are some studies about the installation of piers and deflectors in these structures, generally with respect to air concentration and flow behavior, such as Pfister (2006), Wang et al. (2012), Mojtaba et al. (2015) and Terrier (2016).

The present research focuses on the analysis of the jet behavior and on the study of the pressures developed along a stepped chute with pre-aeration by deflector and air supply by an airtight chamber. The data were acquired through pressure transducers installed on a reduced scale physical model.

### 2 METODOLOGY

The reduced scale physical model utilized in this research consists of a stepped spillway built in metal with a Creager ogee localized in the Laboratório de Obras Hidráulicas - LOH (IPH/UFRGS – Brazil). The model scale is 1:15, the stepped chute is 1V:0.75H sloping and 0.5 m wide, and the steps are 0.06 m high. The aeration induction is provided by a deflector positioned between the ogee and the first step and an air supply by an airtight chamber connected to a slot located on the first step.

The deflector and the air supply system are constructed in acrylic material. Figure 1 and Figure 2 show a picture and a scheme of the air induction system into the flow, and Figure 3 shows the slot located in the vertical face of the first step. The air supply system has the purpose of reassuring the airflow and has a tube of PVC, with an internal diameter of 69 mm and a length of 70 cm, connected on the airtight chamber. The deflector tested is 10 mm high and has an extension of 21.5 mm from the vertical face of the subsequent step, according to Figure 4.

The water supply system is assured by three hydraulic pumps and the flow rates are controlled through the flow meters present in each section of the pipeline. The unit discharges tested were from 0.054 m<sup>3</sup>/s/m to 0.400 m<sup>3</sup>/s/m (27 l/s to 200 l/s).



**Figure 1.** Lateral view of the air chamber of the air induction system.

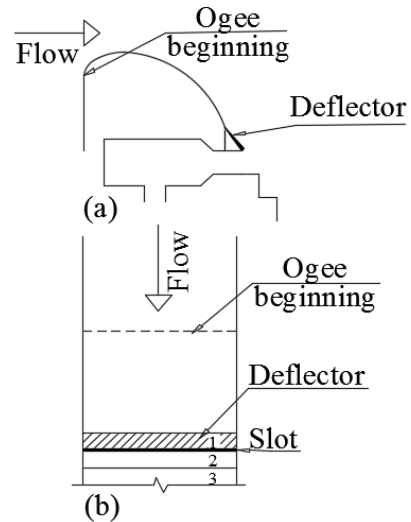

**Figure 2.** Lateral (a) and top (b) view of the air induction system.

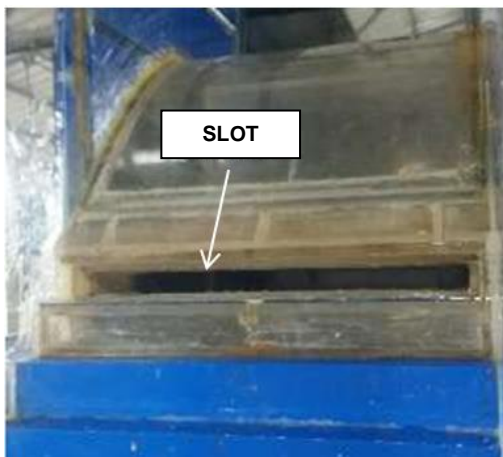

**Figure 3.** Front view of the slot for air supply.

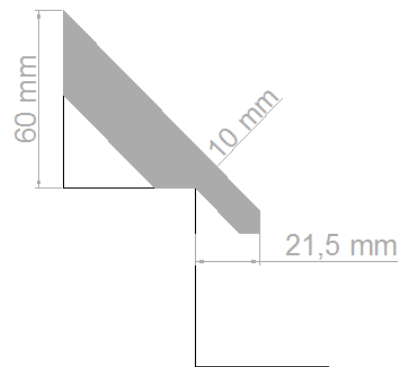

**Figure 4.** Lateral view: deflector for experiments with induced aeration.

Instantaneous pressures data were acquired by transducers Omega brands (model PX419, series OM00 and error of 0.08% F.E), Sitron (model SP96, series S00 and error of 0.5%) and Hytronic (model TM25, series H0 and error of 0.25% FE). The equipments are connected to water intakes through hoses with a length of around 20 cm. In the other side, the transducers are connected to an acquisition board connected to an acquisition system by National Instruments. The pressures were measured near the step edges (8 mm from the external step edge, both the horizontal and vertical faces) on the central axis of the stepped chute. During the tests, also were performed visual analyses observing the location of the jet impact.

In order to compare the induced aeration obtained data, tests were performed with natural aeration flow. These tests were conducted in the same model and with the same unit flows, however, without the aerators elements.

### 3 EXPERIMENTAL RESULTS AND ANALYSIS

In the case of the deflector analyzed, the point of impact of the jet varied for some ranges of discharges, according to the visual analysis. Figure 5 and Figure 6 show the jet impact position corresponding to the situation for minimum and maximum discharges respectively. The result of the jet impact point for all the tested discharges through the visual analysis are displayed in Table 1.

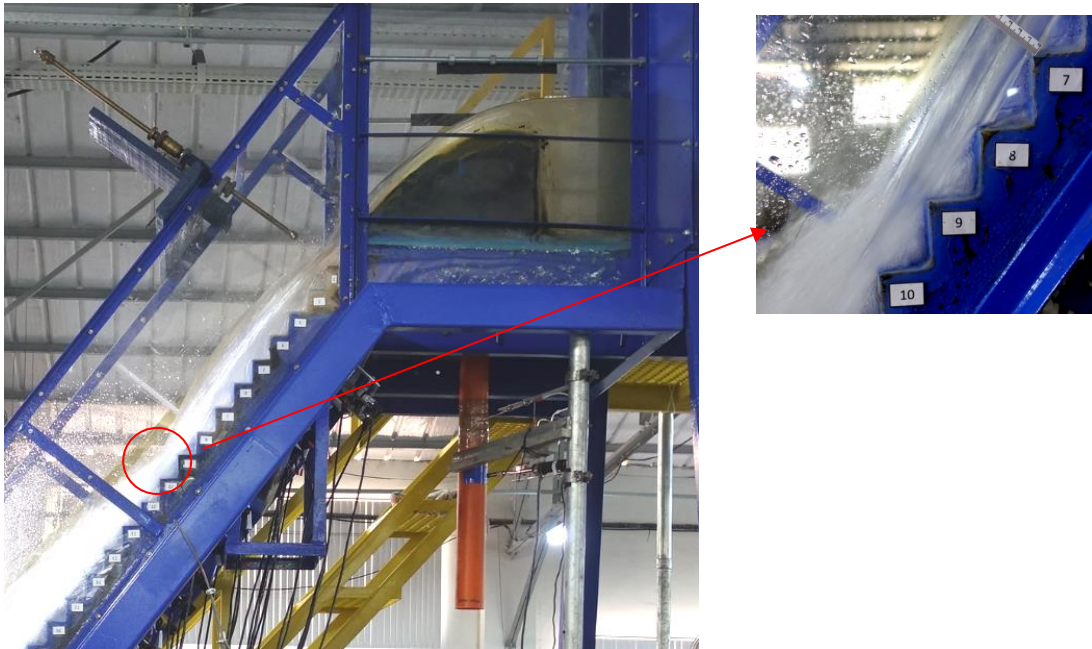

**Figure 5.** Characteristic positions observed for the test discharge 27l/s.

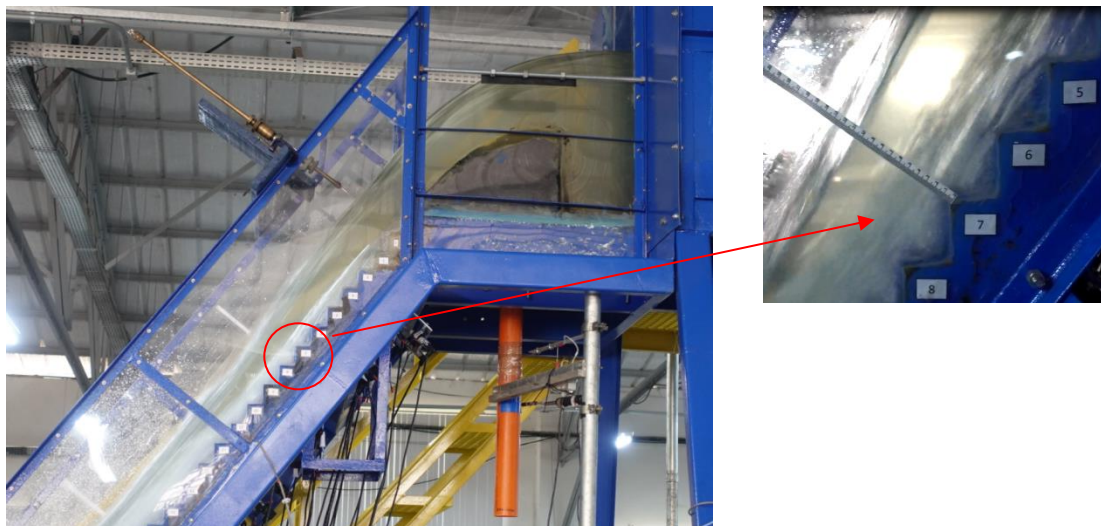

**Figure 6.** Characteristic positions observed for the test discharge 200l/s.

**Table 1. Jet impact steps.**

Q (l/s)	Jet impact step
27	9
41	9
54	9
75	8
100	8
150	8
200	7

For each tested discharge, the mean pressures acquired with induced aeration and natural aeration flow were compared in the graphs shown in Figure 7 and Figure 8, at which the horizontal axis represents the step number and the vertical axis represents the mean pressure head. The mean pressure resulting from the insertion of the deflector and air entrance system are shown in continuous lines, while those resulting from natural aeration are shown in dashed lines.

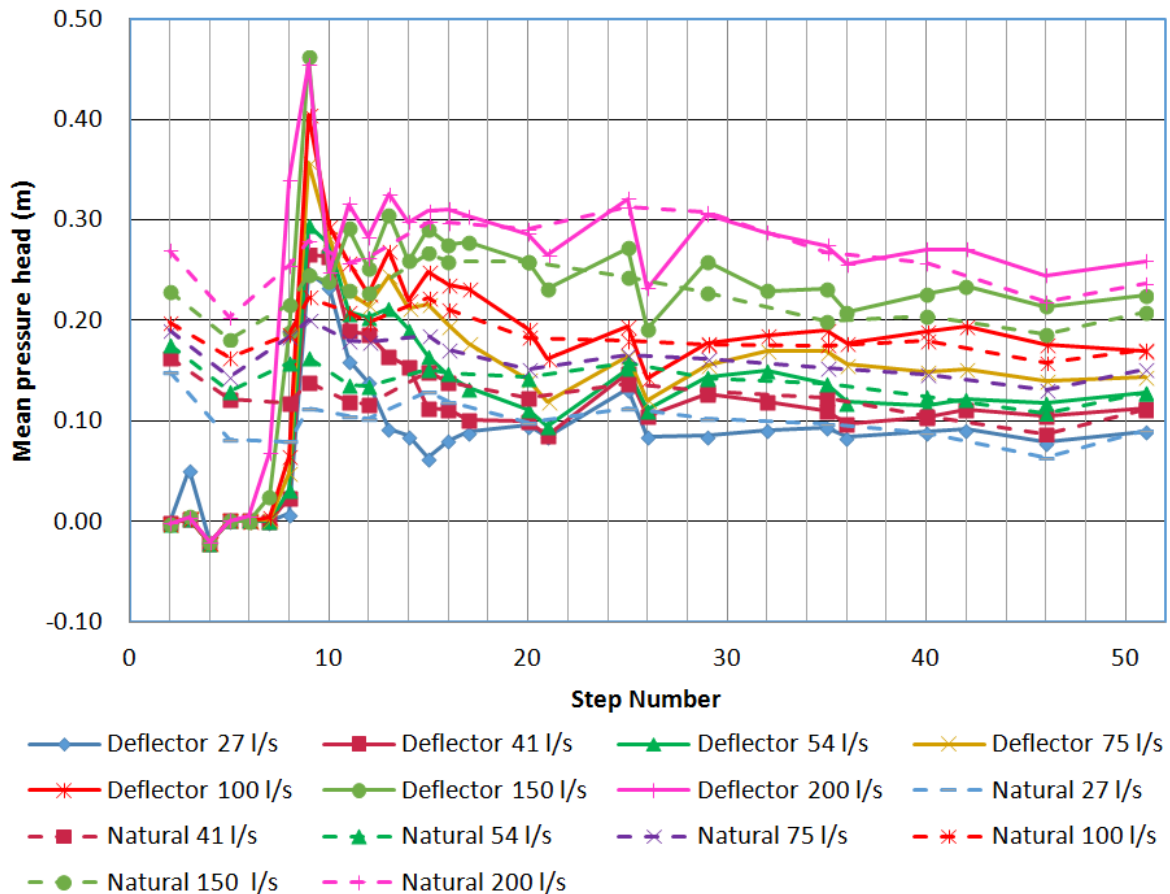

Figure 7. Mean pressure head on horizontal faces of the steps.

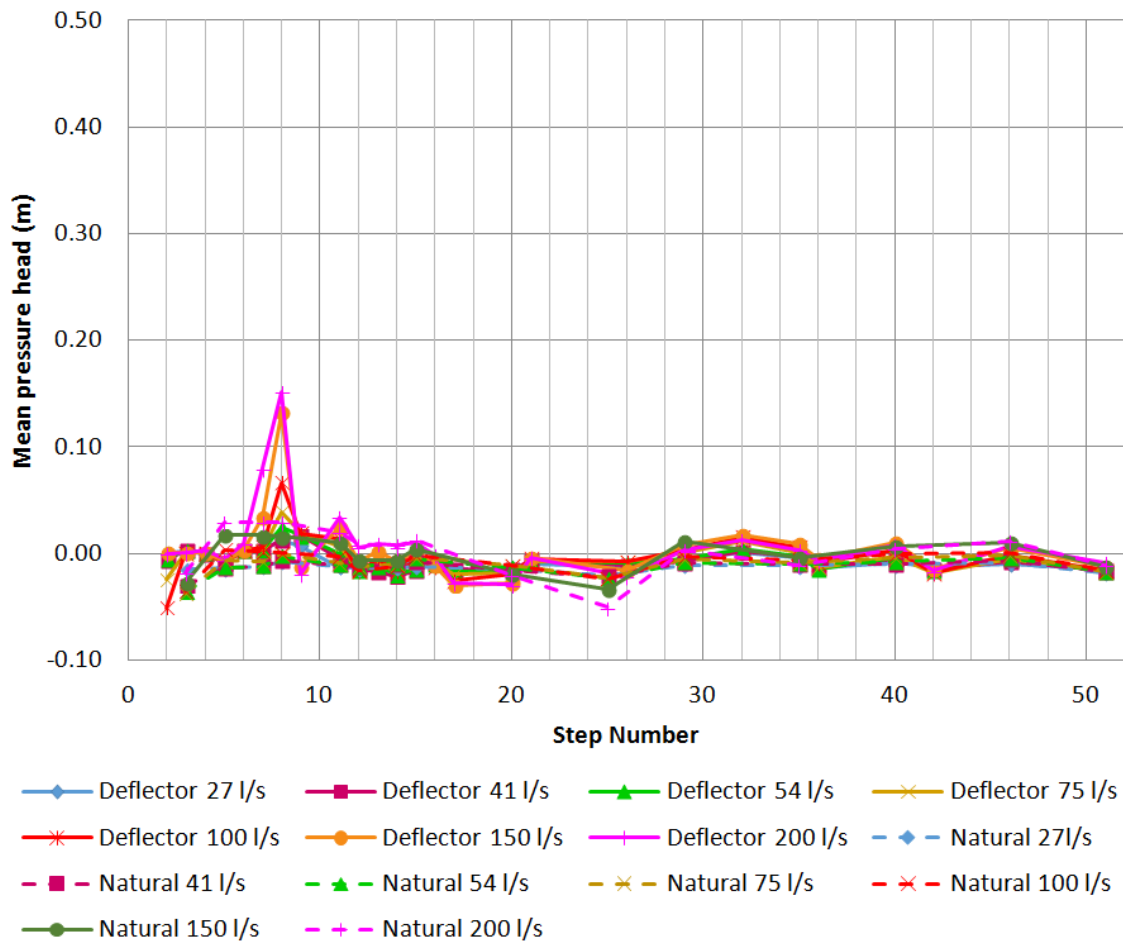

Figure 8. Mean pressure head on vertical faces of the steps.

In the horizontal faces of the steps it can be noticed a peak of positive pressures corresponding to the jet impact region. That peak, with pressures higher than the same values with the natural aeration condition, develops in step 9 regardless of the tested discharge. This result goes against the jet impact position visually observed as can be seen on Table 1. A possible explanation is that, with the discharge increasing, the jet becomes thicker and a greater share of water detach from the main flow and reaches the steps of the chute further upstream than the main flow, seem to be that, apparently, the jet impact occurs upstream in relation to the lower discharges.

Upstream the jet impact position, the pressures head on the chute were close to zero, lower than the data observed in the case of natural aeration due to the steps are not being in contact with water. In this case, the steps are subjected to pressures close to the atmospheric pressure, due to existence of the slot in the step that allows air entrance.

Downstream of the jet impact point, there was observed some oscillation in the magnitude of the mean pressures and the values tend to be similar to the values obtained with natural aeration. In the final steps of the spillway, the flow had stable mean pressures.

In the vertical faces of the steps, a peak of positive pressures can be seen on step 8 for all tested discharges. In the region upstream of the jet impact, the mean pressures were close to zero upstream of the jet impact region, as shown in Figure 8. However, as the flow rates increase, negative pressures arise downstream of the jet impact. These values are higher than the same observed to the tests with natural aeration. Downstream of the jet impact position, such as to the horizontal faces of the steps, it is perceived that the mean pressures value oscillates tending to values similar to the same obtained with natural aeration.

Comparing the Figure 7 and Figure 8, it can be noticed that the pressures on horizontal faces of the steps are, predominantly, positive and, in the vertical faces of the steps, pressures are negative for induced and natural aeration. For the horizontal faces of the steps, an increase on the discharge means an increase on the magnitude of the mean pressure for both aeration conditions. For the vertical faces of the steps, the discharge influence is not evident. Furthermore, it was observed that the peak of positive pressures on the region of the jet impact observed to induce aeration is higher in the horizontal faces of the steps.

#### **4 CONCLUSION**

This paper had the purpose to analyze the jet region and the mean pressures in a stepped spillway with the addition of a deflector and an air supply system. In the horizontal faces of the steps, a peak of pressure was observed in the region of the impact of the jet, higher than the peak which occurred on the vertical faces, and the values were higher than the values obtained in the natural aeration. Upstream of the jet's impact, for horizontal and vertical faces of the steps, pressures are close to zero and, downstream of the jet impact region, there was an oscillation between higher and lower values in comparison to natural aeration. Furthermore, it was observed that the discharge influences the mean pressures on the horizontal faces of the steps, causing a pressure increase for the higher discharges. In order to conclude if the insertion of an air supply system means a real advantage associated to the pressures occurred on a stepped chute, it is necessary a more extensive study comprehending pressures with different probabilities of non-exceedance.

#### **5 ACNOWLEDGMENTS**

The writers would like to acknowledge the Coordenação de Aperfeiçoamento de Pessoal de Nível Superior (CAPES/Brazil), the Conselho Nacional de Desenvolvimento Científico e Tecnológico (CNPq/Brazil), the Financiadora de Estudos e Projetos (FINEP/Brazil), Centrais Elétricas Brasileiras S.A. (Eletrobras), the Fundação de Amparo à Pesquisa do Estado do Rio Grande do Sul (FAPERGS/Brazil), Furnas Centrais Elétricas S.A., the Fundação de Apoio Universitário (FAU/UFPel) and the Instituto de Pesquisas Hidráulicas (IPH/UFRGS) for providing the conditions and the financial support for the realization of the experimental work.

#### **REFERENCES**

- Amador, A., Sánchez-Juny, M. and Dolz, J. (2009). Developing Flow Region and Pressure Fluctuations on Steeply Sloping Stepped Spillways. *Journal of Hydraulic Engineering*. 135(12): 1092-1100.
- Dai Prá, M. (2004). Características do escoamento sobre vertedouros em degraus de declividade 1V:1H. Master's thesis. Universidade Federal do Rio Grande do Sul. Porto Alegre (in Portuguese).
- Gomes, A.J.F. (2006). Campo de Pressões: Condições de Incipiência à Cavitação em Vertedouros em Degraus com Declividade 1V:0,75H. Ph.D. thesis, Universidade Federal do Rio Grande do Sul. Porto Alegre (in Portuguese).
- Mojtaba et al. (2015). Experimental study of effect of installing deflector on replacement of inception point of air entrainment in stepped spillways. *Journal of Scientific Research and Development* 2 (4): 11-16.
- Novakoski et al. (2018). Comparação da dissipação de energia ao longo de uma calha em degraus com aeração natural e aeração forçada. XXVIII Congresso Latinoamericano de Hidráulica. Buenos Aires (in Portuguese).
- Osmar, F.M. 2016. Análise de esforços sobre vertedouros em degraus de declividade 1V:0,75H. Master's thesis. Universidade Federal do Rio Grande do Sul. Porto Alegre (in Portuguese).
- Peterka, A. (1953). The effect of entrained air on cavitation pitting. *Hydraulic Engineer, Design and Construction Division, Bureau of Reclamation*. Denver.
- Pfister, M., Hager, W.H. and Minor, H.E. (2006). Bottom aeration of stepped spillways. *Journal of Hydraulic Engineering*, v. 132, p. 850-853.
- Terrier, S. (2016). Hydraulic performance of stepped spillway aerators and related downstream flow features. Ph.D. thesis, Ecole Polytechnique Fédérale de Lausanne. Lausanne.
- Wang, S., Dong-Mei, H. and Wang, C. (2012). Aerator of stepped chute in Murum Hydropower Station. In: 2012 International Conference on Modern Hydraulic Engineering. 2012, Nanjing. Nanjing: Procedia Engineering, p. 803-807.

